

User Guide

Arcadia Central Station User Guide



Part Number: PUB-00021 Revision C

September 09, 2022

Document reference

Arcadia® Central Station User Guide

Part Number:PUB-00021 Revision C

Legal disclaimers

Copyright © 2022 HME Clear-Com Ltd

All rights reserved

Clear-Com and the Clear-Com logo are trademarks or registered trademarks of HM Electronics, Inc.

The software described in this document is furnished under a license agreement and may be used only in accordance with the terms of the agreement.

The product described in this document is distributed under licenses restricting its use, copying, distribution, and decompilation / reverse engineering. No part of this document may be reproduced in any form by any means without prior written authorization of Clear-Com, an HME Company.

Clear-Com Offices are located in California, USA; Cambridge, UK; Dubai, UAE; Montreal, Canada; and Beijing, China. Specific addresses and contact information can be found on Clear-Com's corporate website: www.clearcom.com

Clear-Com contacts

Americas and Asia-Pacific Headquarters

California, United States

Tel: +1 510 337 6600

Email: SalesSupportUS@clearcom.com

Europe, Middle East, and Africa Headquarters

Cambridge, United Kingdom

Tel: +44 1223 815000

Email: SalesSupportEMEA@clearcom.com

China Office

Beijing Representative Office

Beijing, P.R. China

Tel: +8610 59000198/59002608

Email: SalesSupportChina@Clearcom.com

Table of contents

Table of contents	3
1 Introduction	7
1.1 Arcadia Central Station	8
1.2 Connections	12
2 System Examples	13
2.1 Arcadia with FreeSpeak II Wireless - E1	14
2.2 Arcadia with FreeSpeak II Wireless E1 and Splitter	16
2.3 Arcadia with FreeSpeak II and Edge Wireless IP Transceivers	18
2.4 Split Frequency Setup (5, 2.4 and 1.9 GHz System)	20
2.5 Arcadia as HelixNet System Host	21
2.6 Arcadia with FreeSpeak E1 and HelixNet	21
3 Installing Arcadia Central Station	22
3.1 Front Panel Connectors, Controls and Indicators	23
3.2 Front Panel Touchscreens	24
3.3 Rear Panel Connectors and Indicators	27
3.4 System Powering	28
3.5 Clear-Com Ethernet Cable Recommendations	30
3.6 Stage Announce and Program Feed	31
4 Configuring from the Front Panel	32
4.1 Introduction to Configuring from the Front Panel	33
4.2 Setting the Management IP Address	33
4.3 Passwords, Addresses, Reset to Default, Save and Restore Configuration	34
4.4 Front Panel Menus	36
5 The Core Configuration Manager (CCM)	42
5.1 Introduction	43
5.2 Accessing the CCM	44
5.3 Changing the CCM Password	45
5.4 Setting the Management IP from the CCM	46
5.5 Saving and Restoring System Configuration	46

5.6 Resetting to Default	47
5.7 Hardware Page Overview	48
5.8 Configuring Station Settings	53
5.9 Configuring the Network	54
5.10 Arcadia® Central Station LAN Configuration Rules	54
5.11 Setting Up the Wireless Beltpack System	55
5.12 Upgrading	57
5.13 Configuration Page Overview	58
5.14 Channels Page	59
5.15 Channels and Groups	59
5.16 Managing Channels	61
5.17 Groups Page	67
5.18 Managing Groups	67
5.19 Roles Page	74
5.20 Managing Roles	74
5.21 Logic Page	84
5.22 Setting up GPIOs and Logic Events	84
5.23 Status Page	87
5.24 Monitoring System Status	88
6 Using FreeSpeak Wireless Intercom	95
6.1 Overview of Transceivers	96
6.2 Connecting Transceivers Over E1	96
6.3 Adding IP Transceivers (FS Edge, FS II 1.9)	100
6.4 Connecting Transceivers Over IP	101
6.5 Network Setup for IP Transceivers	102
6.6 Registering Beltpacks (FreeSpeak)	106
7 Using HelixNet Wired Partyline Intercom	109
7.1 Introduction	110
7.2 HelixNet Connections - General Outline	111
7.3 Connecting HelixNet user stations to the network	112
7.4 Pairing HelixNet user stations to the Base Station	113

Belpacks	114
Remote stations and speaker stations	115
8 Using Dante Systems	116
9 Using 2-Wire Systems	120
9.1 Introduction to 2-Wire Systems	121
9.2 Using Stations to Interconnect Equipment	122
10 Using 4-Wire Systems	124
10.1 Introduction to 4-Wire Systems	125
10.2 Port Function	126
10.3 Using Stations to Interconnect Equipment	127
11 Upgrading Firmware	129
11.1 Introduction	130
11.2 Upgrading using the CCM	130
11.3 Upgrading using a USB stick	130
11.4 HelixNet Upgrade	131
12 Licensing	132
12.1 Port Licenses	133
12.2 Online Activation of Additional Licenses	133
12.3 Offline Activation of Additional Licenses	134
13 Security	140
13.1 Warning	141
13.2 Introduction	141
13.3 Using Security Certificates	142
13.4 Forcing HTTPS	142
14 Appendix A: Pinouts	145
14.1 GPIO pinouts	146
14.2 2-Wire Pinouts	148
14.3 4-Wire Pinouts	149
14.4 DECT Sync	149
15 Appendix B: Specifications	150
15.1 Arcadia® Central Station	151

15.2 Capacity	155
15.3 Network Specifications	156
16 Appendix C: Spare Parts	158
17 Appendix D: Front Panel Menu Reference Tables	159
17.1 Audio Settings	160
17.2 Host Settings	160
17.3 2 W Audio (A/B) (C/D)	161
17.4 Discovery	161
17.5 Transceiver	162
17.6 Networking	163
17.7 Administration	164
18 Appendix E: Regulatory Compliance (Regulatory Model: 1410)	167
18.1 FCC Notice	168
18.2 FCC/IC/EC RF Exposure Warning	169
18.3 Industry Canada Compliance Statement	169
18.4 Korean Notice	169
18.5 European Union (CE mark)	170
18.6 United Kingdom (UKCA Mark)	170
18.7 Electrical and Electronic Equipment (WEEE) Waste	171

1 Introduction

This chapter provides an overview of the Arcadia® Central Station. It contains the following sections:

1.1 Arcadia Central Station	8
1.2 Connections	12

1.1 Arcadia Central Station

The Arcadia® Central Station provides a scalable IP networked intercom system. It has a compact 1RU form and can be configured either from the browser-based Core Configuration Manager (CCM) or from the front panel menu system. The Arcadia intercom system supports both wireless (FreeSpeak) and wired (HelixNet) user stations, in a variety of form factors, frequencies and connectivity types.

As an intercom user station, Arcadia provides 4 keysets with high resolution touch-screen control. Keysets are assignable to any channel, group, beltpack, program audio or stage announce. The user station has a headset connection, a gooseneck mic connector and a loudspeaker, in addition to All Call, Stage Announce and Remote Mic Kill buttons.

Arcadia interfaces with a variety of audio and intercom systems; Dante, 4-wire line-level audio, 2-wire partyline connections to existing analog intercom systems. GPIO connections provide inputs and relay outputs for system control and interfacing, programmable in Arcadia's logic configurator (navigate to:**CCM>Configuration>Logic**).

1.1.1 Features

- Combined wired and wireless intercom
- Scalable capacity licensing
- Dante and analog interfacing
- Intuitive CCM browser configuration
- Front panel touch screen with encoders for control and configuration
- Plug-and-go with central discovery and pairing
- GPIO control and interfacing

1.1.2 Maximum System Capacity

• Wireless intercom



• Wired intercom



- **Dante ports up to 64** (subject to licensed ports)
- **4-wire ports x 8** (Port 8 = program feed and stage announce)
- **2-wire ports x 4** (Clear-Com and RTS)

FreeSpeak wireless intercom

- 10 E1 transceivers (1.9, 2.4 GHz)
- 16 IP transceivers (1.9 GHz, 5 GHz)
- 40 beltpacks* (1.9, 2.4, 5 GHz)

HelixNet wired intercom

- 24 HelixNet enabled channels*
- 64 HelixNet endpoints (Beltpacks, remote station, speaker station)

Dante audio network interfaces

- 64 Dante ports*

*Subject to licensed port capacity

Hardwired ports

- 8 four-wire connections
 - Port 8 is dedicated to program feed and stage announce audio

- 4 two-wire connections
 - Clear-Com or RTS

System limits

- 100 channels
- 100 groups
- 200 roles

1.1.3 Licensed Ports – Scalable Port Capacity



1 wireless beltpack consumes 1 licensed port



1 channel consumes 1 licensed port

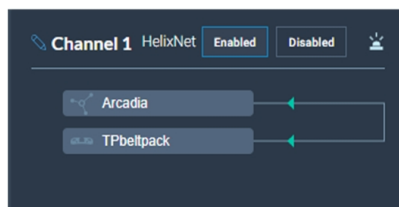

1 HelixNet enabled channel consumes 1 licensed port

Up to 128 licensed ports, available in increments of 16. Licensed ports are consumed by:

- One FreeSpeak beltpack (1 port)
- One HelixNet enabled channel (1 port)
- One Dante channel (1 port)

How many licensed ports do I need? Use the *Arcadia Online Licensed Port Calculator* available from the Arcadia Knowledge Center.

Part number	Licensed ports
ARCADIA-X4-16P	16 Licensed ports
ARCADIA-X4-32P	32 Licensed ports
ARCADIA-X4-48P	48 Licensed ports
ARCADIA-X4-64P	64 Licensed ports
ARCADIA-X4-80P	80 Licensed ports
ARCADIA-X4-96P	96 Licensed ports
ARCADIA-X4-112P	112 Licensed ports
ARCADIA-X4-128P	128 Licensed ports

1.1.4

More Information

For more information, refer to the [Arcadia Knowledge Center](#).



www.clearcom.com/arcadia-knowledge-center

1.2 Connections

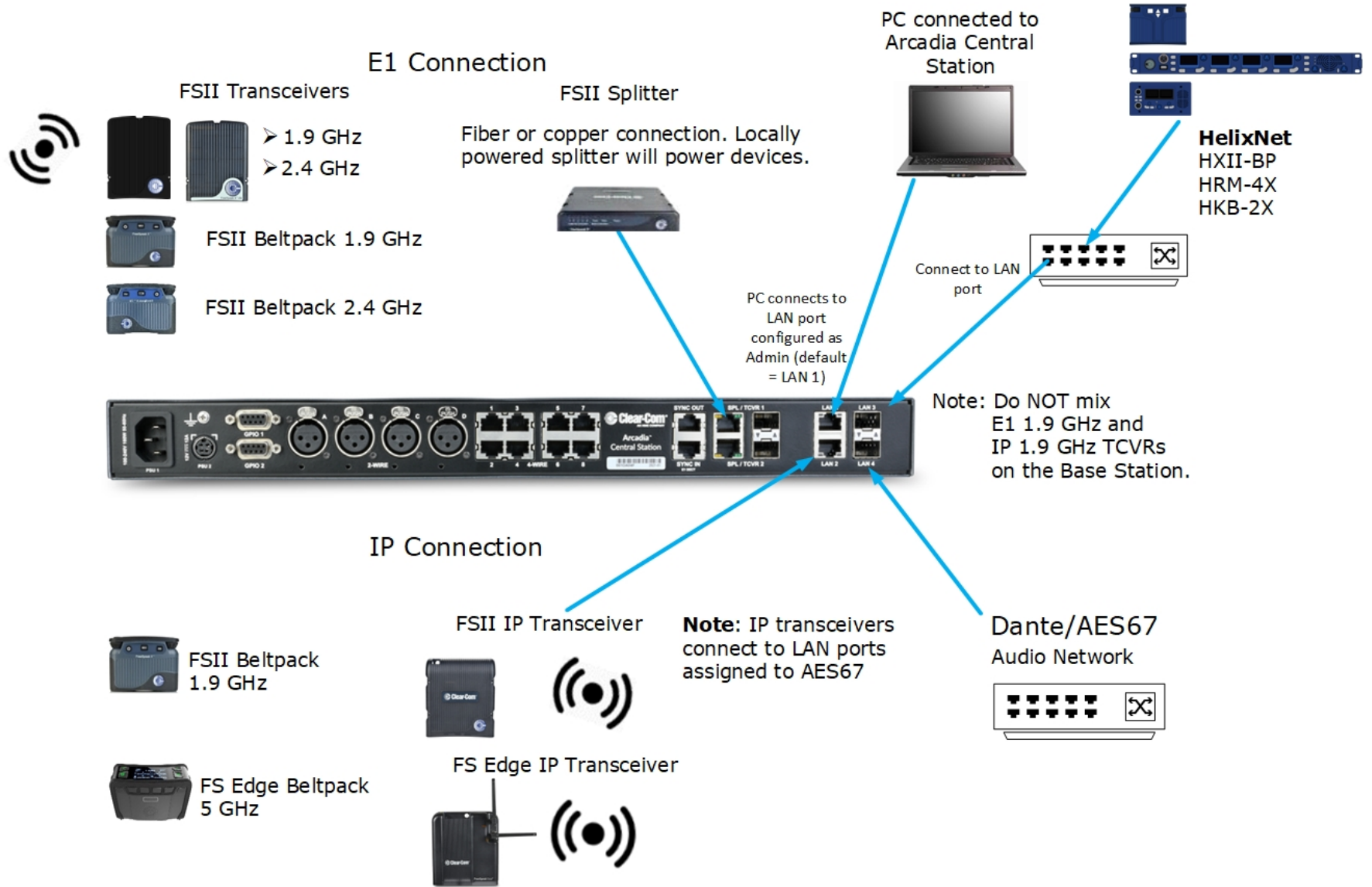

2 System Examples

This chapter contains examples of typical applications. It contains the following sections:

2.1 Arcadia with Freespeak II Wireless - E1	14
2.2 Arcadia with FreeSpeak II Wireless E1 and Splitter	16
2.3 Arcadia with FreeSpeak II and Edge Wireless IP Transceivers	18
2.4 Split Frequency Setup (5, 2.4 and 1.9 GHz System)	20
2.5 Arcadia as HelixNet System Host	21
2.6 Arcadia with FreeSpeak E1 and HelixNet	21

2.1 Arcadia with Freespeak II Wireless - E1

The FreeSpeak II E1 transceivers use an E1 connection (telecommunications standard) directly to the Arcadia Central Station. The Core Configuration Manager (CCM) is the easiest way to configure your system, but this setup can be configured with minimal use of the CCM if you work with the default role setup. Using the default setup, all devices have talk and forced listen keys to Channel 1 and Channel 2 and can engage call signals to those channels.

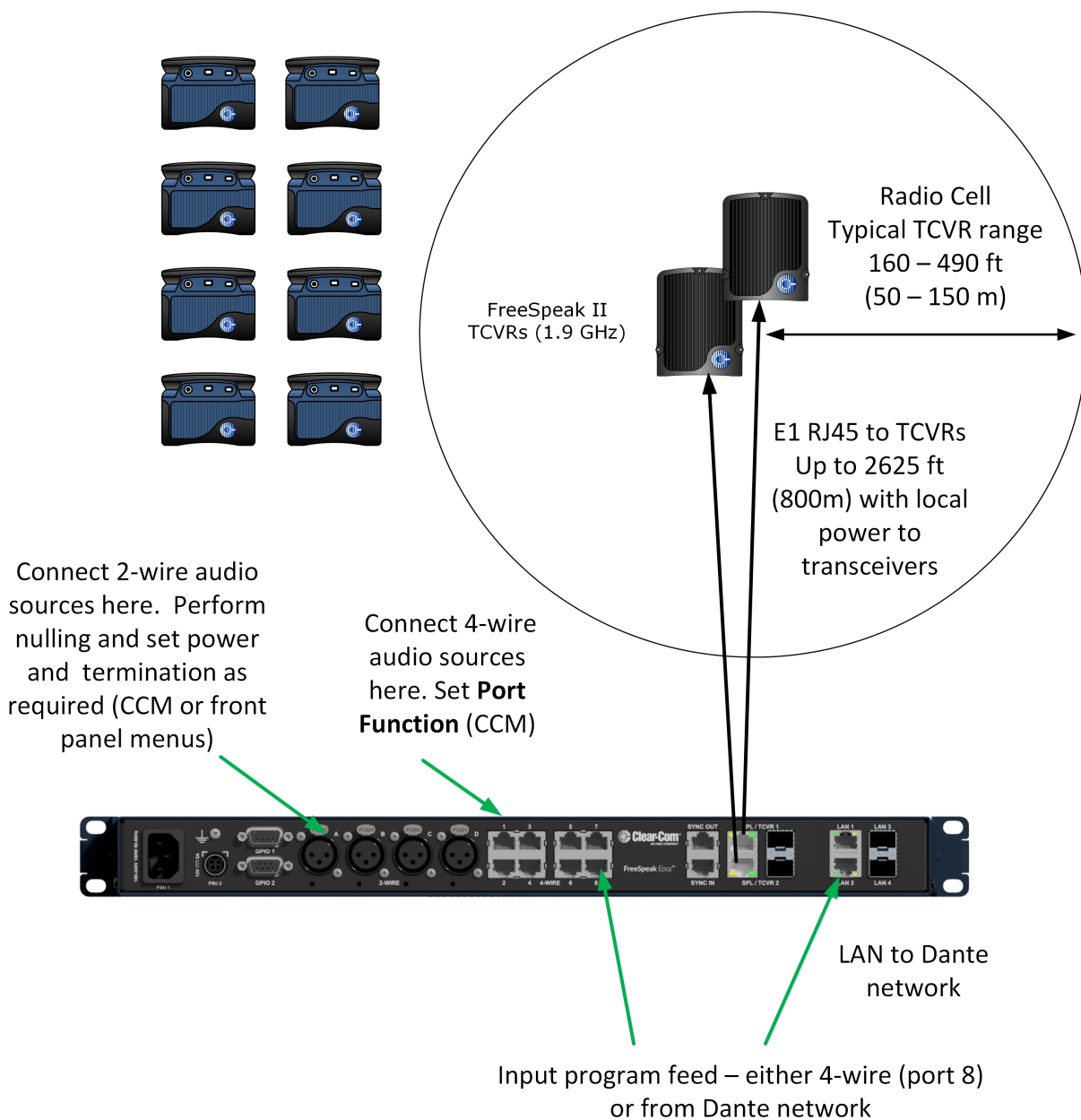

2.1.1 Outline of General Setup and Configuration

- For E1 setup, see [Connecting Transceivers Over E1 on page 96](#).
- To access the CCM, see: [The Core Configuration Manager \(CCM\) on page 42](#).
- To register beltpacks, see [Registering Beltpacks \(FreeSpeak\) on page 106](#).
- To set Port Function, see [Port Function on page 126](#).
- To perform null and set power, see [Using 2-Wire Systems on page 120](#).
- To connect Program Feed, see [Stage Announce and Program Feed on page 31](#).

2.2 Arcadia with FreeSpeak II Wireless E1 and Splitter

This setup includes two splitters, both connected via shielded Cat 5e cable using E1 connectivity. Four channels are configured in the CCM: Channel 1=ALL, Channel 2=Lighting, Channel 3=Sound, Channel 4=FoH. 16 roles are configured for the beltpacks.

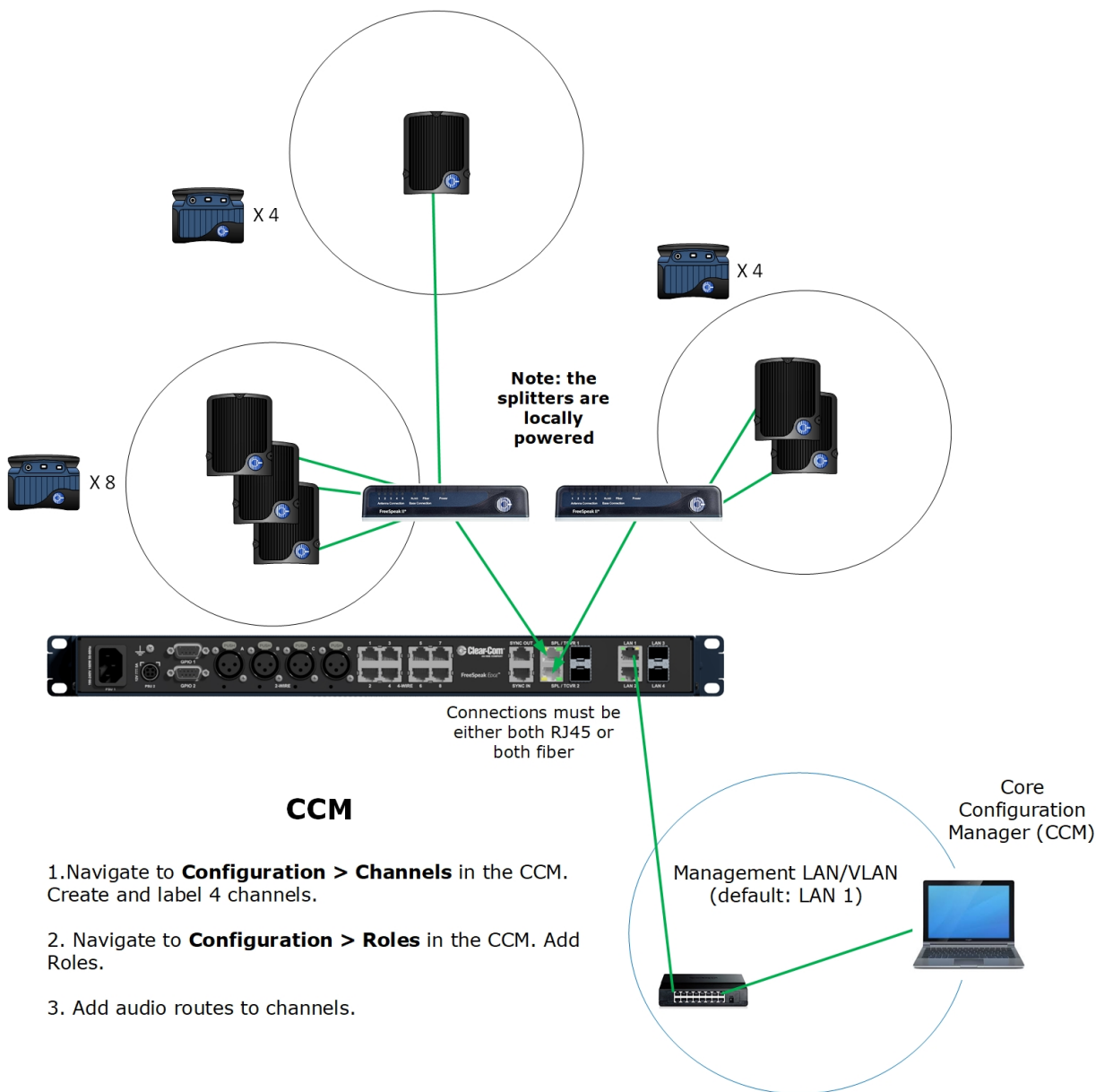

2.2.1 Outline of General Setup and Configuration

- For E1 setup, see [Connecting Transceivers Over E1 on page 96](#).
- To set the splitter DIP switches, see the FSII Splitter Quick Start Guide (FSII SPL-QSG) in the Clear-Com FreeSpeak II Knowledge Center on the Clear-Com website:
[Clear-Com FreeSpeak II Knowledge Center](#)
- To access the CCM, see: [The Core Configuration Manager \(CCM\) on page 42](#).
- To register beltacks, see [Registering Beltacks \(FreeSpeak\) on page 106](#).
- To set port settings for 2-wire sources, see [Using 2-Wire Systems on page 120](#).
- To set port settings for 4-wire sources, see [Using 4-Wire Systems on page 124](#).
- To connect program and stage announce, see:
[Stage Announce and Program Feed on page 31](#).
- To configure channels, see [Managing Channels on page 61](#).
- To configure Roles, see [Managing Roles on page 74](#).

2.3 Arcadia with FreeSpeak II and Edge Wireless IP Transceivers

This setup has a total of 6 FS Edge transceivers with 16 Beltpacks connected. The IP transceivers are connected via a network that is configured for AES67 traffic. These are configured using the CCM. There are four 2-wire partylines and a Dante network.

Note: *The Dante network must be on a different VLAN or network from the IP transceivers.*

Note: *The AES67 network must be set up correctly for the IP transceivers in order to meet the needs of Clear-Com IP transceivers for high levels of PTP accuracy.*

See the *AoIP Network Recommendations* guide, available from the [Clear-Com FSII Knowledge Center](#).

FS Edge 5 GHz
beltpacks x 16

Register at the
Base or in the
CCM



Note: This setup assumes a dedicated network switch for the Edge Base, transceivers and CCM.

Note: You cannot configure the IP transceiver network (AES67) and Dante to the same network port.

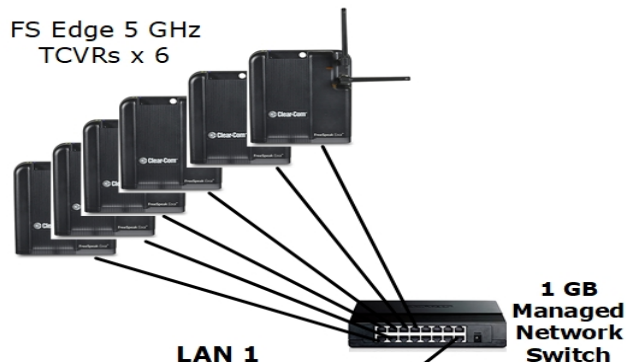

LAN 1
Management (CCM)
and AES67

LAN 2
Dante

1. You will need to use the **Discovery** feature in the CCM to add IP transceivers to your system.

2. You will need to configure Dante feeds in the Audinate Dante Controller before these can be added to channels in the CCM.

Key
Cat5e/6a Shielded
Ethernet cable
23/24 AWG
(max 100m)

2.3.1 Outline of General Setup and Configuration

- For network setup, see [Network Setup for IP Transceivers on page 102](#).
- To access the CCM, see: [The Core Configuration Manager \(CCM\) on page 42](#).
- To add IP transceivers to your system, see [Using FreeSpeak Wireless Intercom on page 95](#).
- For information on the connection process for IP transceivers, see the Quick Start Guides (QSGs) for FS Edge IP transceivers available from the [FreeSpeak Edge Knowledge Center](#).
- For information about connecting to 2-wire systems, see: [Using 2-Wire Systems on page 120](#).
- For information about connecting to Dante, see: [Using Dante Systems on page 116](#).
- For information about Channels, see [Managing Channels on page 61](#).
- For information about Roles, see [Managing Roles on page 74](#).

2.4 Split Frequency Setup (5, 2.4 and 1.9 GHz System)

This setup has:

- E1 FS II transceivers (1.9) with 5 beltpacks
- E1 FS II transceivers (2.4) with 4 beltpacks
- FS Edge IP transceivers (5) with 10 beltpacks
- FS II IP transceivers (1.9) with 10 beltpacks.

The E1 Transceivers will automatically connect to the Arcadia Central Station once powered, but the Edge IP transceivers require additional configuration in the CCM and must be connected to a network that is configured for AES67 traffic.

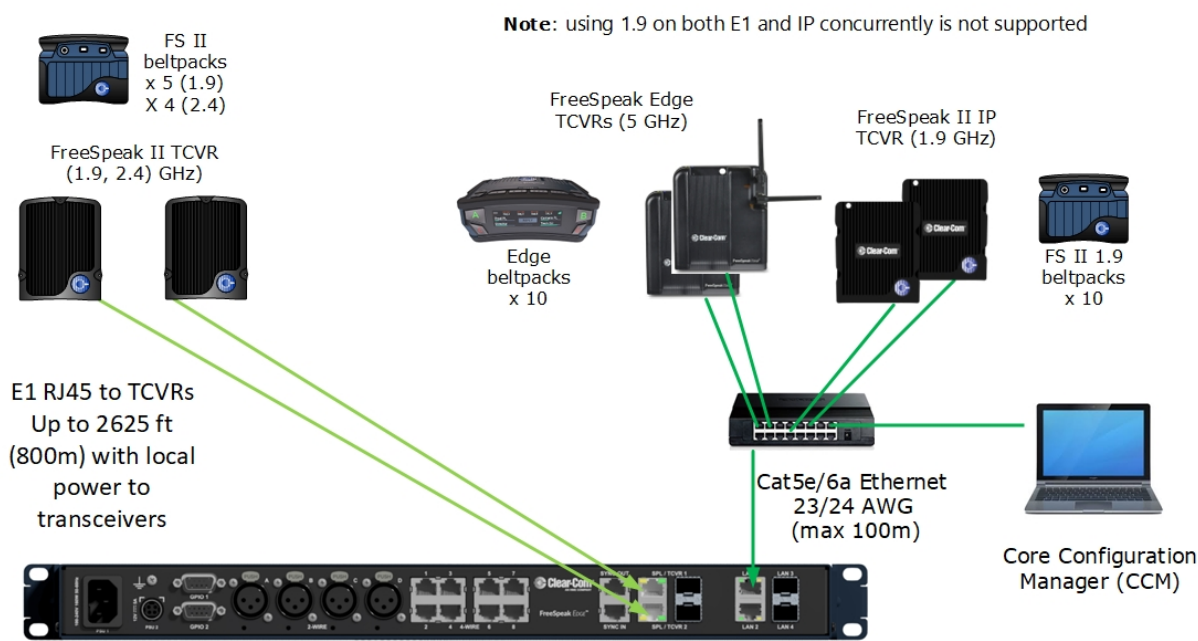

CCM Configuration

2 x Channels: Cameras, Lighting

16 x Roles: Director, Stage Manager, Runners, Maintenance, Lighting, Sound

Note: you can create roles that can be used by FS Edge and/or FS II beltpacks (the role can only be used by 1 beltpack at any given time).

2.5 Arcadia as HelixNet System Host

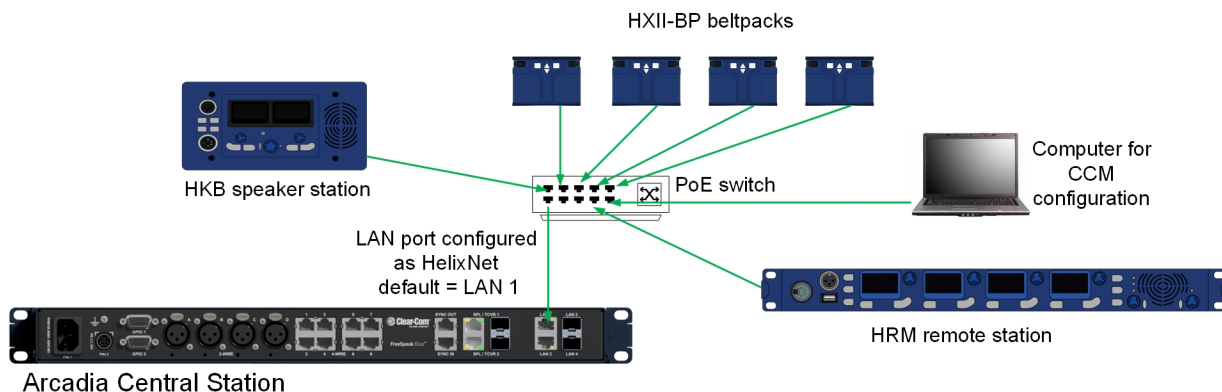

Up to 24 HelixNet enabled channels and 64 HelixNet endpoints (subject to licensed ports).

For information on how to configure this set up see [Using HelixNet Wired Partyline Intercom on page 109](#).

2.6 Arcadia with FreeSpeak E1 and HelixNet

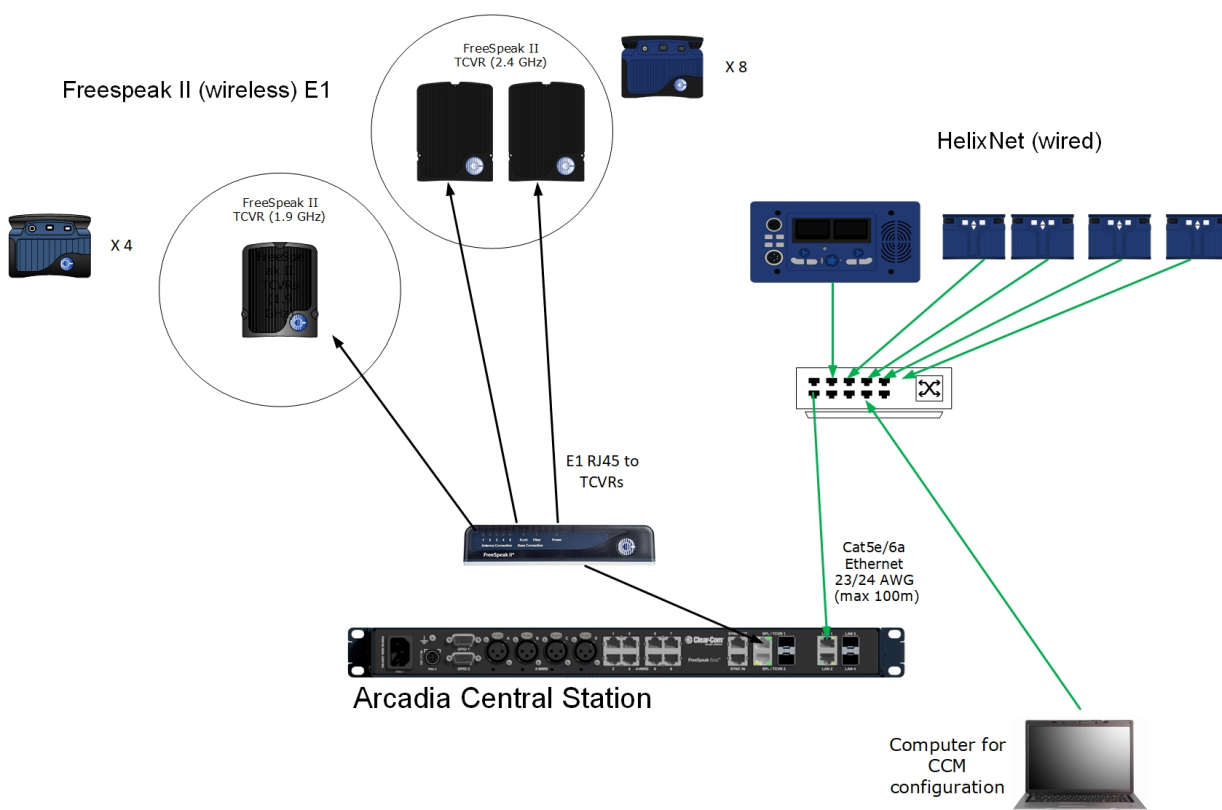

To configure FreeSpeak with E1 see [Connecting Transceivers Over E1 on page 96](#)

To configure HelixNet in Arcadia see [Using HelixNet Wired Partyline Intercom on page 109](#)

3 Installing Arcadia Central Station

This chapter describes the front and rear panels, power supplies and cabling recommendations. It also describes network setup and illustrates example applications. It contains the following sections:

3.1 Front Panel Connectors, Controls and Indicators	23
3.2 Front Panel Touchscreens	24
3.3 Rear Panel Connectors and Indicators	27
3.4 System Powering	28
3.5 Clear-Com Ethernet Cable Recommendations	30
3.6 Stage Announce and Program Feed	31

3.1 Front Panel Connectors, Controls and Indicators

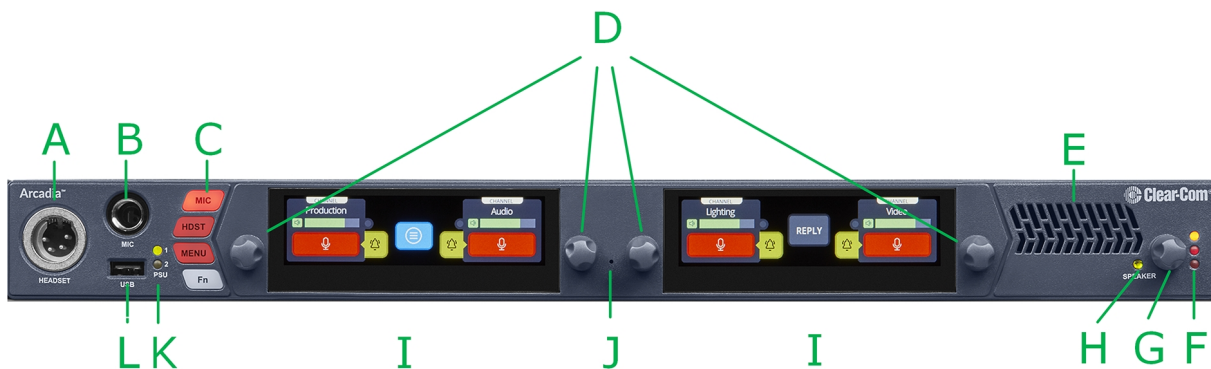

The Arcadia front panel connectors, controls and indicators are listed below.

Item	Description
A	Headset connector (4-pin or 5-pin XLR).
B	Gooseneck mic socket (1/4-inch jack)
C	<p>Mic: Toggles microphone audio on and off to the keysets on the unit (similar to the Talk button). The Mic button overrides the effect of a latched talk on a keyset.</p> <p>HDST: When a headset is connected, this button switches audio between the headset microphone and the gooseneck microphone.</p> <p>Menu: Press to enter menu mode. Press again to exit, or allow menu mode to time out.</p> <p>Fn: Function button. For future use.</p>
D	Rotary Encoders. Use these to control channel volume or to navigate through the menu system.
E	Loudspeaker
F	<p>Main Volume Level LEDs:</p> <ul style="list-style-type: none"> • Red - high volume level • Amber - medium volume level • Green - low volume level
G	Main Volume Control. This controls the listen levels for both the speaker and the headset. Pressing this control will mute/unmute the speaker audio output.

Item	Description
H	Speaker active LED: lights green when the speaker is active. Arcadia Central Station channel audio is heard here. The speaker is automatically active when there is no headset plugged into the Arcadia Central Station.
I	Color touchscreen displays
J	Pin reset. Pin reset causes the device to power cycle (reboot)
K	Power input status indicators
L	USB A connector. Use to: <ul style="list-style-type: none"> • Register beltpacks • Upgrade the Arcadia Central Station • Save/Restore system settings • Obtain detailed logs for diagnostic purposes

3.2 Front Panel Touchscreens

The Arcadia Central Station has two intercom control touchscreens, available when the front panel screens are not in menu mode. Each touchscreen provides access to two keys which can be configured for channels, groups or point to point communications channels.

3.2.1 Left Intercom Touchscreen

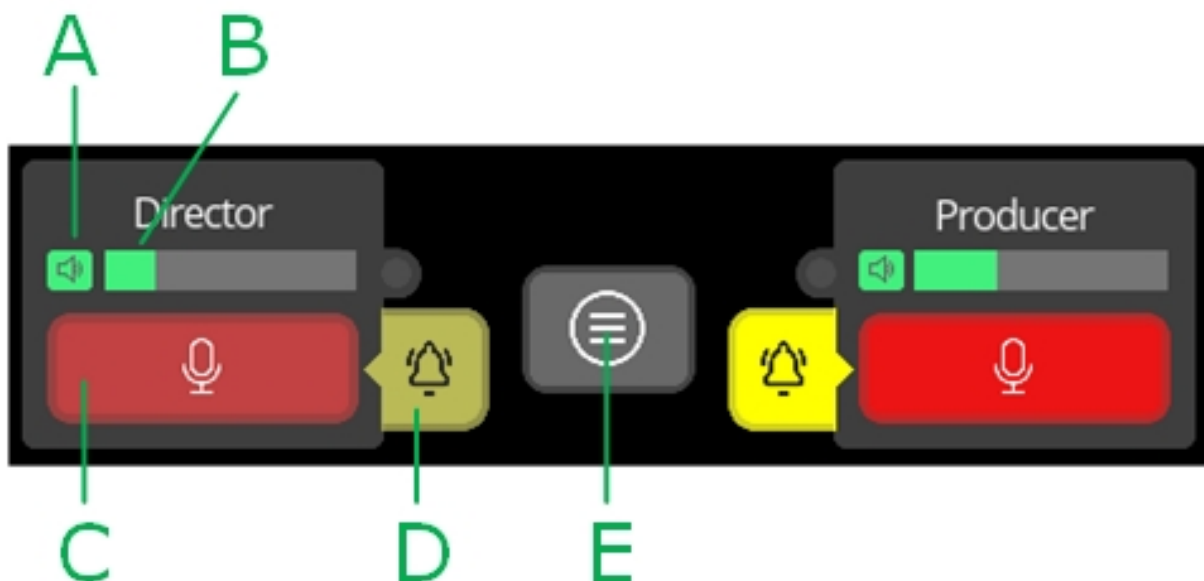

Item	Description
A	Listen activation indicator.
B	Volume level indicator. Control the volume with the rotary controller next to the channel/audio source.
C	Talk button.
D	Call button. Use this to send a call signal.
E	Menu button. Touch to see: <ul style="list-style-type: none"> • Stage Announce • All talk • Remote mic kill (RMK)

3.2.2 Right Intercom Touchscreen



Item	Description
A	Channel indication. Channels are set in the CCM: Configuration>Roles>Arcadia Central Station . Audio routes can be point-to-point or channels.
B	Notification bar <ul style="list-style-type: none">• Beltpack registration• Progress of upgrades• Support information gathering• Resoration of configuration progress
C	Reply button. Use CLEAR to clear the currently visible entry (does not clear the entire key stack).

3.3 Rear Panel Connectors and Indicators

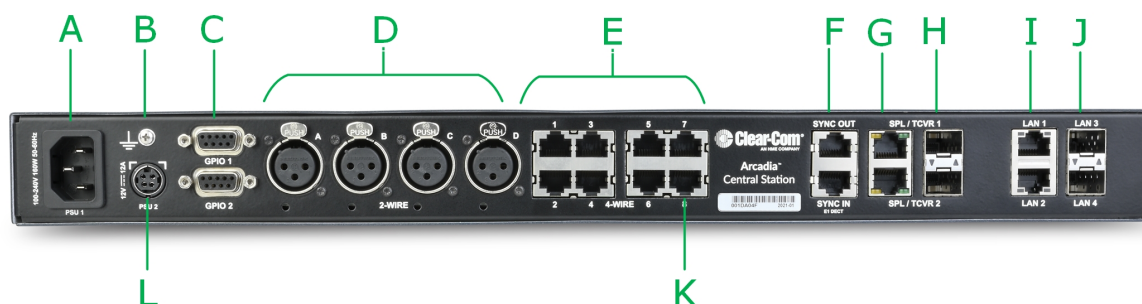

The Arcadia rear connectors and indicators are listed below.

Item	Description
A	Internal power connector. Mains power lead with internal power supply.
B	Grounding screw.
C	General Purpose Input/Output connectors x2 (DB-9F). <ul style="list-style-type: none"> GPIO 1 hosts GPI1 and GPO1 & 2 GPIO 2 hosts GPI2 and GPO 3 & 4.
D	XLR 2-wire Partyline connectors (analog)
E	RJ45 4-wire audio and data connectors. Port 8 is dedicated to Program Feed (PGM) and Stage Announce (SA), to be used with the split XLR cable connector that is supplied with the Arcadia Central Station.
F	Dect Sync RJ45 connectors, IN, OUT.
G	E1 RJ45 connectors to FreeSpeak II splitter/transceiver. Do not connect IP transceivers here.
H	SFP cage for E1 fiber connection to splitter/transceiver. Either single-mode or multi-mode fiber modules. Modules must match existing cabling. Do not connect IP transceivers here.
I	RJ45 LAN connectors. Assignable to Management, Dante primary, Dante secondary, AES67 for FreeSpeak IP transceivers or HelixNet.
J	SFP cage for fiber LAN connectors. Assignable to Management, Dante primary, Dante secondary, AES67 for FreeSpeak IP transceivers or HelixNet.

Item	Description
K	Program Audio input and Stage Announce output. Use with supplied RJ45 to XLR adaptor cable..
L	External power supply connector. CAUTION: Before using, see System Powering on page 28 .

3.4 System Powering

Arcadia features dual power inputs:

- Mains power connector (IEC) internal power supply
- DC connector. External AC/DC power adapter (12V DC, 12A)

Both power inputs can be connected in parallel for redundancy.

3.4.1 Using the External DC Power Connector

CAUTION: YOU MUST CONNECT THE EXTERNAL DC POWER SUPPLY IN THE ORDER DESCRIBED AND ILLUSTRATED BELOW:

1. Connect the external power supply 12V cable connector (A) to the rear chassis 12V input connector of the Station.

Note: When connecting the power cable, be sure to push until the connector locks into the device.

Station (rear, left-side)



2. Connect External Power Supply mains cord (B) to the AC input source.

Mains connector

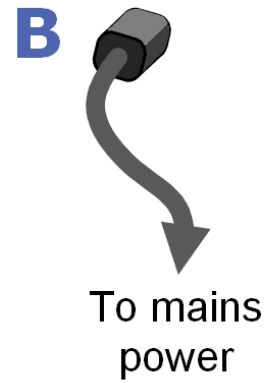

3.5 Clear-Com Ethernet Cable Recommendations

Cable recommendations	
Category (Cat)	<p>Higher Cat numbers will support a higher bandwidth. Therefore, by using a higher Cat number you are future proofing your system to some extent. Example:</p> <ul style="list-style-type: none"> • Cat 5e : up to 1 GB • Cat 6: up to 10 GB <p>Use Cat 5e or higher.</p>
American Wire Gauge (AWG)	<p>The lower the AWG number, the less temperature rise there will be in the cable when using PoE. This is particularly important for bundles. Local building regulations may rule out the use of 26 AWG or higher, depending on the installation. Check with your local building regulations. Use AWG 24 or lower.</p>
Shielded Twisted Pair (STP) or Foiled Twisted Pair (FTP)	<p>Using shielded cable means less problems with interference from other sources. This means that your installation will be more robust if you use shielded cables.</p>

Note: Overall recommendation: Use Cat 6a, 23 AWG STP cable.

3.6 Stage Announce and Program Feed



Your Arcadia® Central Station is supplied with an RJ45 connector that uses a splitter cable to split into two XLR connectors. If you wish to use an external Stage Announce (**SA**) and Program audio (**PGM**), you must connect this to the RJ45 port labeled **SA/PGM** (port 8) on the rear of your device, and connect your input (**PGM**) and output (**SA**) to these connectors.

Navigate to **Configuration > Channels** in the CCM and click the add button  next to the PGM and SA ports to put them into channels as required. These audio resources can be routed with **Channels**, **Groups**, **Roles** and **Logic** events (GPIOs).

Note: *These resource are unidirectional (simplex, not duplex).*

4

Configuring from the Front Panel

This chapter describes how to configure the Arcadia® Central Station from the front panel. It contains the following sections:

4.1 Introduction to Configuring from the Front Panel	33
4.2 Setting the Management IP Address	33
4.3 Passwords, Addresses, Reset to Default, Save and Restore Configuration	34
4.4 Front Panel Menus	36

4.1 Introduction to Configuring from the Front Panel

Some common tasks you might perform from the front panel menus are:

- See/configure the Arcadia Central Station IP address
- See the default CCM password
- Null your 2-wire audio ports
- Reset the Arcadia Central Station to factory settings
- Reset the CCM password

To enter the Arcadia Central Station menu system, press the **Menu** button on the front panel. Navigate through the hierarchical menu using the rotary controllers. To select or commit a menu item, press the rotary encoder next to it.

To exit the menu system, press the Menu button again, or leave the device to time-out of menu mode (20 seconds).

4.2 Setting the Management IP Address

By default your Arcadia Central Station works with DHCP. However, you can set a static IP address for any of the station Ethernet ports (with the exception of Dante audio that is defined by the Audinate Dante Controller).

The Management IP address can be set:

- From the Arcadia Central Station front panel menus
- From the CCM

4.2.1 Setting the Management IP Address from the Front Panel Menus

1. Press the **MENU** button.
2. Using the far left rotary controller, navigate to **Networking**.
3. Select **Management**.
4. Navigate to **DHCP** and select **DISABLED**. Push to select menu item.
5. A numerical touchscreen keypad appears in the screen.
6. Using the touchscreen, press **Clr** to clear the IP address field.
7. Enter the new IP address using the touchscreen.
8. Press **OK**.
9. Edit the subnet if required.
10. Press **OK**.
11. The Management IP address has been changed.

For more information, see: [Arcadia® Central Station LAN Configuration Rules on page 54](#).

4.3 Passwords, Addresses, Reset to Default, Save and Restore Configuration

You can find the Arcadia Central Station IP address, manage the CCM password and reset to default settings.

4.3.1 Find the Arcadia Central Station IP Address

1. Press the **Menu** button on the front of the Arcadia Central Station.
2. Navigate to **Networking > Management > IP Address** using the rotary controllers.
3. You will see the device IP address.



4.3.2 Find the default password for the CCM

1. Press the **Menu** button on the front of the Arcadia Central Station.
2. Navigate to **Administration > CCM Access > Default Password** using the rotary controllers.
3. You will see the default password in the right hand menu screen.

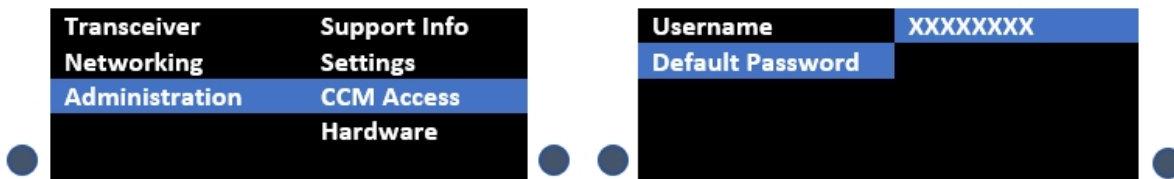

4.3.3 Reset the device to default settings

1. Press the **Menu** button on the front of the Arcadia Central Station.
2. Navigate to **Administration > Reset > Reset To Default > Reset Base**.
3. The Arcadia Central Station will reset to factory settings.

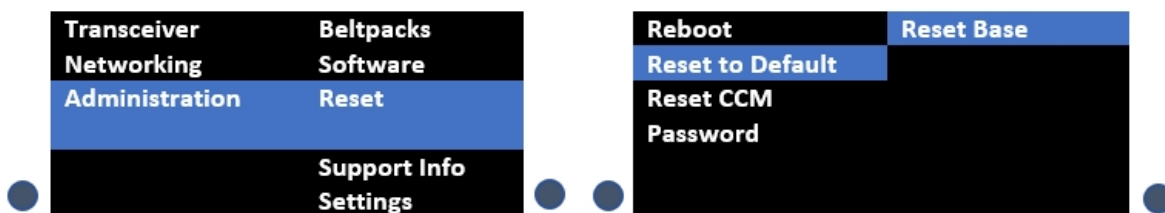

Note: When you use a pin reset on front the front of the Arcadia Central Station the device power cycles (reboots).

Note: When resetting the Arcadia Central Station to default settings using the front panel menu system, all the system configuration details, including network settings are reset. The management IP of the Arcadia Central Station will change.

Note: When you reset the Arcadia Central Station to default settings, you must **Add** the IP transceivers to the system again. See [Adding IP Transceivers \(FS Edge, FS II 1.9\) on page 100](#).

Note: HelixNet endpoints will all revert to default configuration.

4.3.4 Reset the CCM password

1. Press the **Menu** button on the front of the Arcadia Central Station.
2. Using the right hand rotary controller select **Administration > Reset > Reset CCM Pass.**
3. Press the right hand rotary controller.
4. The password will reset to its default setting.



4.3.5 Save/Restore System Setup

1. Insert a USB drive into the USB connector on the front of the Arcadia Central Station.
2. Press the **Menu** button.
3. Using the rotary controllers, navigate to **Administration > Settings > Save.**
4. Push the 4th rotary controller. System settings are saved to the USB drive. The progress of this Save is shown in the notification bar on the front panel.
5. The file is saved in a folder called **/backupConfig/** in the USB. The file name format is **hostNameDateTime.cca.**

Note: *When you restore system settings in the CCM, Network and OTA System ID settings are optional. This is NOT the case when restoring from the front panel menus. If you want to restore system settings taken from different Stations, you must use the CCM Restore option, as restoring directly from the Arcadia Central Station in this situation would restore network and OTA system ID and IP and could cause wireless ID conflicts.*

4.4 Front Panel Menus

The front panel menu options are listed below.

4.4.1 Audio Settings

Headset

- **Headset Limit.** This allows the user to set the headset limiter for the front panel headset.
 - -12 dB to +8 dB/ OFF
- **HS Mic Type**
 - Dynamic (default)
 - Electret
- **Sidetone Gain**
 - -12 dB to +8 dB (-12 dB default)
- **Sidetone Control**
 - Tracking (default)
 - Non-Tracking
 - Disabled

GooseNeck

- Electret
- Dynamic

4.4.2 Host Settings

Host Name. Pushing the fourth rotary will open the on screen keyboard to allow the user to enter a new name for the device (touchscreen). [OK] when done.

Display

- Screen Brightness. High, Medium (default), Low, Very Low
- Screen Dimming. The screen will dim to Very Low when there is no activity. Timeout time: 1,2 (default),3,5,10 or 15 minutes.
- Touchscreen sensitivity: Low, Medium (default), High.

4.4.3 2W Audio (A,B)

Configure power settings for 2-wire audio sources and perform nulling.

- Interface - power settings
 - Power detected? Yes/No
 - Power Enabled/Disabled (default = disabled)
 - Mode Clear-Com/RTS (default = Clear-Com)
- Nulling: 2W A and 2W B. Press the rotary control (Start) to perform a null. Nulling is only available if power is detected.

4.4.4 2W Audio (C,D)

See 2W Audio (A,B)

4.4.5 Discovery

- Discover FSII TCVR.
 - Lists all FSII IP transceivers visible on the network. Select the transceiver you wish to register (third rotary). Select **Register** and push the rotary (fourth rotary) to begin the connection sequence.
- Discover FSE TCVR.
 - Lists all FS Edge transceivers visible on the network. Select the transceiver you wish to register (third rotary). Select **Register** and push the rotary (fourth rotary) to begin the connection sequence.

Deregister will remove the transceiver from the system. You will only see the **Deregister** option if the transceiver has been already registered.

4.4.6 Transceiver

Lists all registered transceivers. You can view and edit **Label** and **Cable Comp (E1 only)** here. Pushing the fourth rotary will open the onscreen keyboard (touchscreen). [OK] when done.

- FSII IP. Version, Label.
- FS Edge. Version, Label.
- FSII E1. Version , Label, Cable Comp.

4.4.7 Networking

Management

Configure and view:

- LAN Port Assignment
- DHCP **Enabled**/Disabled
- IP Address (read only when DHCP is Enabled)
- Subnet Mask (read only when DHCP is Enabled)
- MAC Address (read only)

Push the fourth rotary to open the on screen touchscreen keyboard to change IP and Subnet. [OK] when done. The keyboard is only available when DHCP is disabled.

Note: *When changing from DHCP **Enabled** to DHCP **Disabled**, the address previously assigned by the DHCP server will be set as the static address. This can cause IP conflicts so you must change the address to one not provisioned by the DHCP server.*

AES67 (for IP transceivers)

The section of the menu is read only and only shown if the AES67 connection has been configured with a LAN port from the CCM. It shows:

- LAN Port Assignment
- DHCP Enabled/Disabled
- IP Address
- Subnet Mask
- MAC Address

Dante

The section of the menu is read only and only shown if the Dante connection has been configured with a LAN port from the CCM. It shows:

- LAN Port Assignment
- IP Address
- Subnet Mask
- MAC Address

4.4.8 Administration

- Beltpacks
 - Over the Air: Press rotary four to **Start OTA**. Put the Arcadia Central Station in pairing mode for OTA registration of beltpacks (600 seconds).

- BP Role List Sorting:
 - Role Number
 - Alphabetical
- Battery type: use this setting if the beltpacks are not using the supplied Li-ion batteries.
 - Alkaline (default)
 - NiMh (for use in high pressure environments)
- Software
 - Current version
 - Update software from a file on a USB (insert into USB C on front of Arcadia Central Station)
- License (you will not see this menu item on a FreeSpeak Edge Base)
 - Connections - current connected ports on this Arcadia Central Station
 - Licensed Ports
 - Total Ports
 - Wireless Ports
 - HelixNet Ports
 - Dante
 - Any Ports. Licensed ports can be allocated to Wireless, HelixNet, Dante or Any. This is a way to control your system resources. A port allocated to Wireless (for example) will not accept connections of any other type. Ports are able to accept all connections by default (Any). Port type is assigned in the CCM: **CCM > Hardware > Resources > Licensed Ports > Type.**
- Reset
 - Reboot
 - Reset to Default. Reset here will reset role, channel and network details. You will need to **Add** your transceivers back into the system after reset. HelixNet devices will revert to default configuration
 - Reset CCM Password
- Support Info

- Settings
 - Save
 - Restore
- CCM Access
 - Username
 - Default password
- Hardware (view only)

Information is for troubleshooting purposes only. Please note: the serial number in this section is the electronic main board serial number, not the device serial number.

5 The Core Configuration Manager (CCM)

This chapter describes the main pages of the Core Configuration Manager (CCM). It contains the following sections:

5.1 Introduction	43
5.2 Accessing the CCM	44
5.3 Changing the CCM Password	45
5.4 Setting the Management IP from the CCM	46
5.5 Saving and Restoring System Configuration	46
5.6 Resetting to Default	47
5.7 Hardware Page Overview	48
5.8 Configuring Station Settings	53
5.9 Configuring the Network	54
5.10 Arcadia® Central Station LAN Configuration Rules	54
5.11 Setting Up the Wireless Beltpack System	55
5.12 Upgrading	57
5.13 Configuration Page Overview	58
5.14 Channels Page	59
5.15 Channels and Groups	59
5.16 Managing Channels	61
5.17 Groups Page	67
5.18 Managing Groups	67
5.19 Roles Page	74
5.20 Managing Roles	74
5.21 Logic Page	84
5.22 Setting up GPIOs and Logic Events	84
5.23 Status Page	87
5.24 Monitoring System Status	88

5.1 Introduction

The CCM is an easy-to-use browser-based software tool with intuitive menus that enable you to quickly set up, configure and edit your system. It provides an overview of all the system components and interfaces. It is password protected and suitable for use in poorly lit environments.

At-a-glance guide to using the Core Configuration Manager (CCM)



You can access the CCM using the following internet browsers:

- Chrome
- Safari
- Firefox
- Microsoft Edge

5.2 Accessing the CCM

1. Make sure that the Arcadia Central Station is connected to a network using the LAN connector that is configured for management (Default LAN 1) on the rear panel of the device (see [Rear Panel Connectors and Indicators on page 27](#)).
2. Open a supported internet browser on a desktop that is connected to the same network as the Arcadia Central Station.
3. In the browser address field, enter the IP address of the Arcadia Central Station. You can find this from the front panel menus, see [Introduction to Configuring from the Front Panel on page 33](#). The login screen appears:

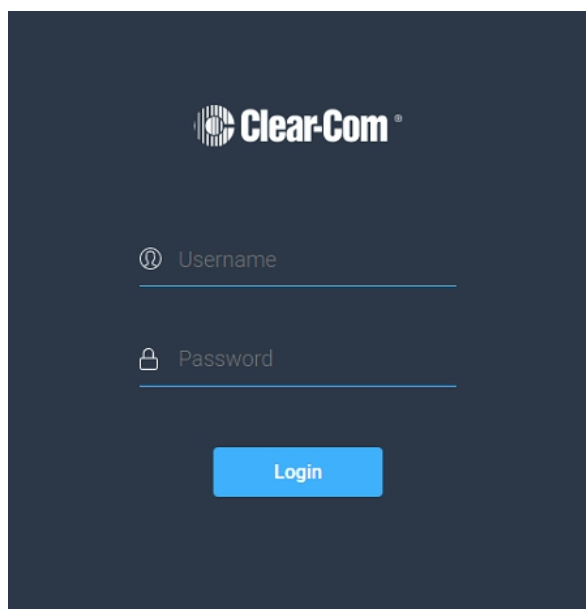

If you enter an incorrect user name or password, an error message appears and you are prompted to re-enter your user credentials.

4. Enter the username and password, and then click **Login**.

The default values are:

- username: **admin**
- password: find the default password in the front panel menu system, see [Passwords, Addresses, Reset to Default, Save and Restore Configuration on page 34](#).

Note: *The username and password are case sensitive.*

The CCM **Hardware** page opens.

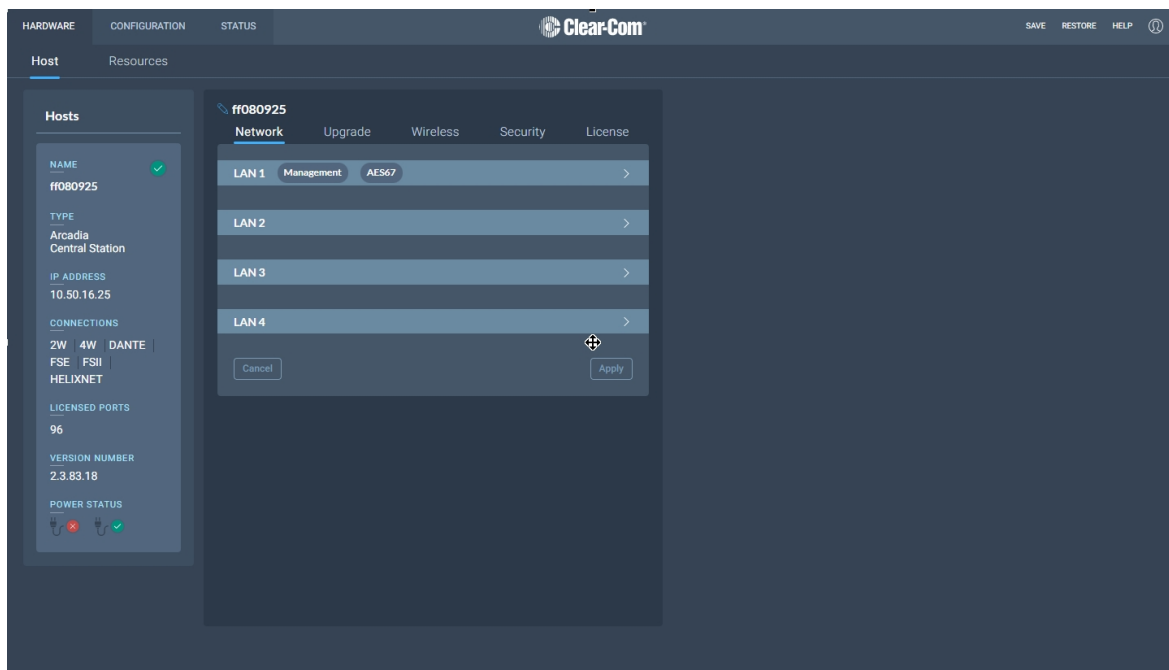

Note: On first opening the CCM, the **Hardware** page opens. On subsequent occasions, the **Status** page opens.

5.3 Changing the CCM Password

Change the password to one of your own choosing in the top right corner of the navigation bar.



Note: You can reset your password to the default at any time from the Arcadia Central Station front panel menus.

5.4 Setting the Management IP from the CCM

To access the CCM, input the Management IP address into a browser. Find the management IP address of the Arcadia in the front panel menu system: **Menu>Networking>Management**.

1. In the CCM, navigate to **Hardware >Host**.
2. In the Network tab, click **Management**.
3. Select **Static**.
4. Enter the required IP address and press the [Enter] key.

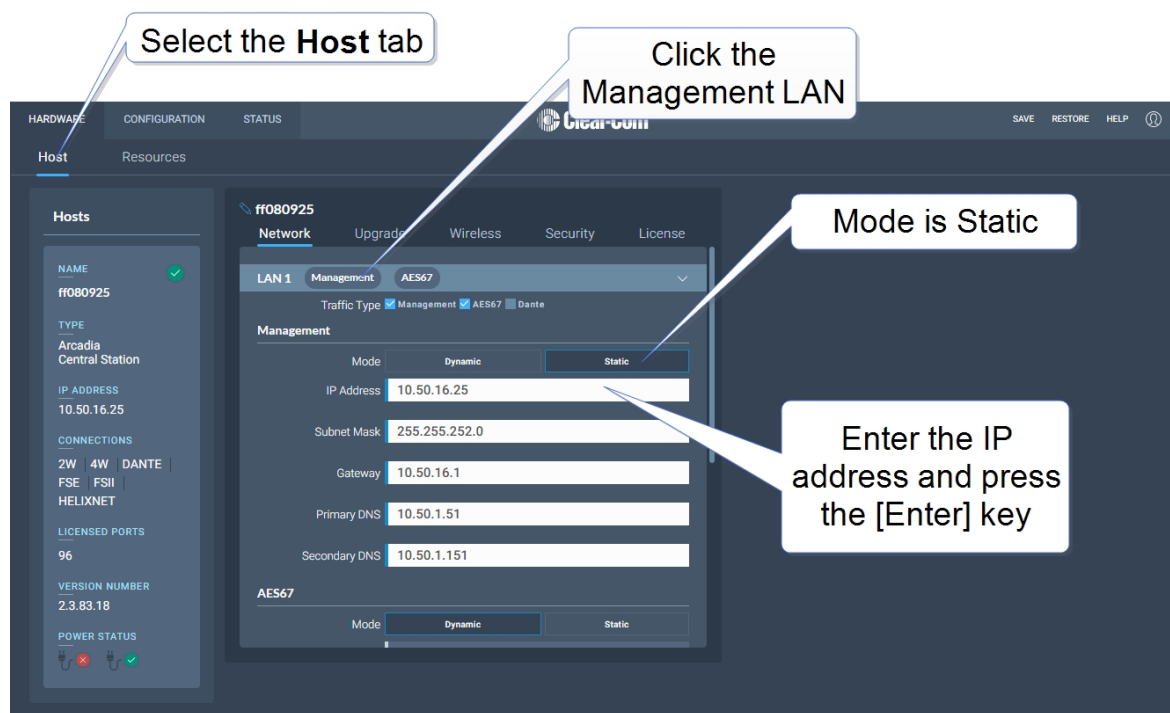

5. For more information, see: [Arcadia® Central Station LAN Configuration Rules on page 54](#).

5.5 Saving and Restoring System Configuration

Clear-Com recommends that you make a backup of your system configuration using the Save option that is available in the CCM and the front panel menu system.

5.5.1 Saving System Configuration in the CCM

The **Save** and **Restore** options are available in the CCM top navigation bar.



When you click **Save**, all system configuration; channels, roles and network details are saved to a file (.cca) on your computer.

5.5.2 Restoring System Configuration

Your system configuration can be restored to the Arcadia Central Station at any time using the **Restore** button in the CCM and also from the front panel menu system.

On restore, the saved configuration is reapplied to the Arcadia Central Station. The following aspects of the configuration are optionally restored:

- Network settings (IP addresses)
- Over The Air system ID.

You do not get these options when restoring by USB directly to the Arcadia Central Station. If you want to restore system settings taken from different Stations, you must use the CCM Restore option, as restoring directly from the Arcadia Central Station in this situation would restore network and OTA system ID and IP and could cause wireless ID conflicts.

5.6 Resetting to Default

Your Arcadia Central Station can be reset to default settings either from the front panel menus or from the Core Configuration Manager (CCM).

Note: *When you use a pin reset on front the front of the Arcadia Central Station the device power cycles (reboots).*

5.6.1 Resetting to Default from the CCM

1. In the CCM, navigate to **Status > Overview > Host Device**.
2. Select **Reset to Default**.
3. From the confirmation dialog box, click **Reset to Default**.
4. The device will reset to factory defaults and reboot.

When resetting to default from the CCM, network settings are not reset, and the password is also not reset. This is not the case when resetting to default from the front panel menus. After reset to default, you will need to re-discover your IP transceivers. HelixNet user stations will revert to default configuration.

5.7 Hardware Page Overview

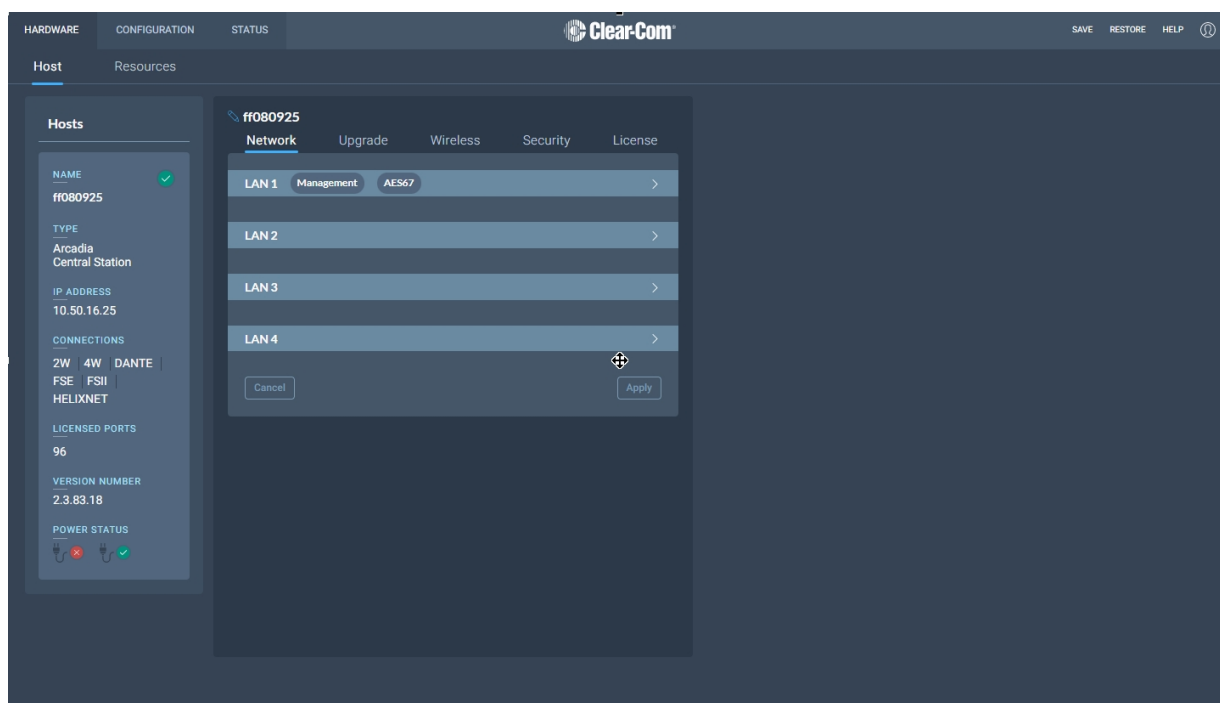

The Hardware page of the CCM is where you set up your system. From the **Hosts** tab you can configure your Arcadia Central Station settings. See [Configuring Station Settings on page 53](#)

5.7.1 The Resources Page

Click the **Resources** tab to see the resources page. This gives an overview of the hardware and ports that are present. From this page, you can use the **Add Resource** button to:

- View a list of both discovered and registered IP transceivers
- View a list of both discovered and paired HelixNet devices

- Add/remove any discovered IP transceivers to/from the system
- Add/remove any discovered HelixNet devices to/from the system
- Register beltpacks to the system
- Create Dante ports
- Adjust settings on interface ports: 2-wire and 4-wire
- Allocate **Licensed Ports** for use with different connection types: **Any, Dante, Wireless, HelixNet**. This allows you to keep track of how you are using the licensed port capacity that you have, and avoid being unable to connect due to lack of available port capacity.

If you click the down arrow in the **Endpoints** section of the screen you will see a list of connected Endpoints. Select an Endpoint (beltpack) to show configuration details such as:

- Fix/unfix a role. If a role is fixed to a beltpack, the user cannot select from a list of roles on powering on the beltpack.
- Unregister (FreeSpeak) or unpair (HelixNet) a beltpack from the system.

The screenshot displays the 'Resources' page in the Clear-Com Arcadia Central Station. The 'Endpoints' section is active, showing a table with columns for Status, Label, ID, Role, and Type. The selected endpoint is 'HXII-BP_c29302' with ID 'C29302' and Role 'TPbeltpack'. A callout box labeled 'Select beltpack' points to the selected row. Another callout box labeled 'Role' points to the 'TPbeltpack' dropdown menu. A third callout box labeled 'Unpair or deregister beltpack' points to the 'Unpair' button in the 'Maintenance' section of the configuration details for the selected endpoint.

5.7.2 Configuring System Resources

- Transceivers
- Physical ports; 2-wire, 4-wire, Stage Announce, Program
- Dante ports
- Licensed ports

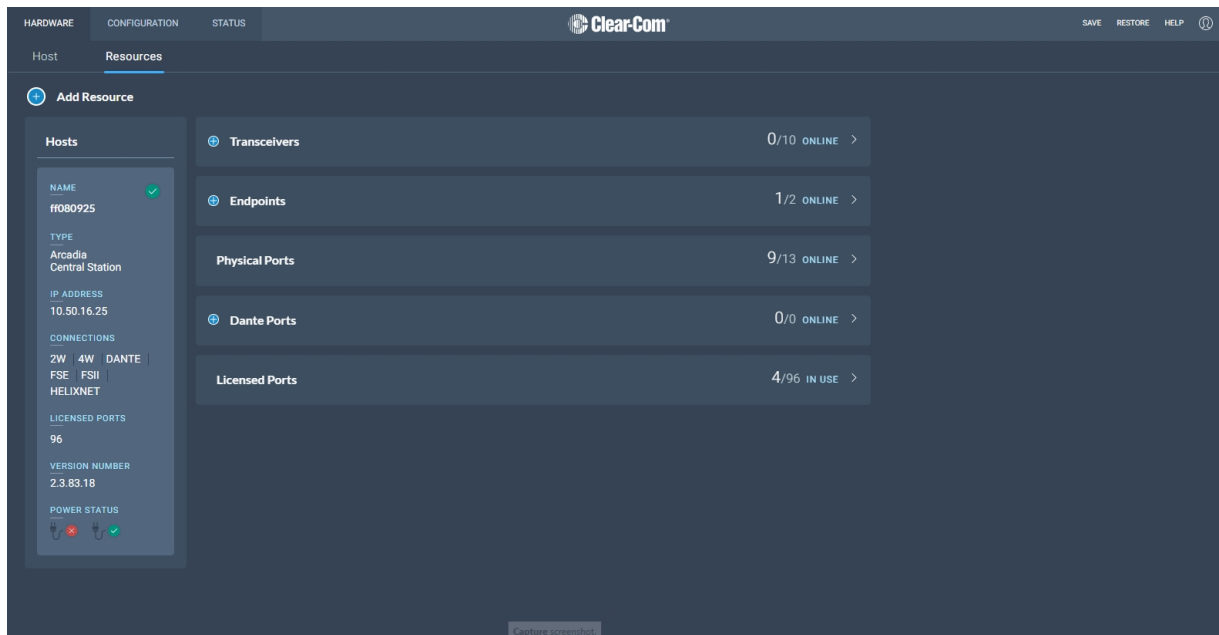

Transceivers

Click the dropdown arrow to see transceivers connected to your system. Select a transceiver to configure it or view details.

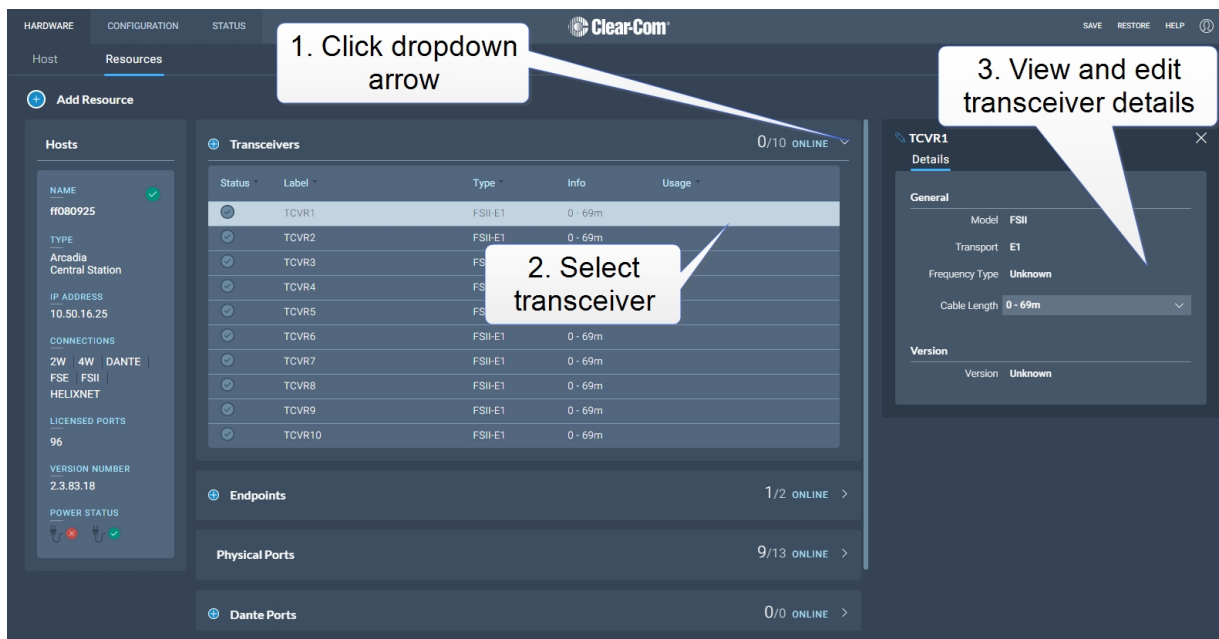

For more information see [Using FreeSpeak Wireless Intercom on page 95](#)

Physical Ports

Click the dropdown arrow to see the physical ports on your Arcadia Central Station. Select a port to configure it or view details.

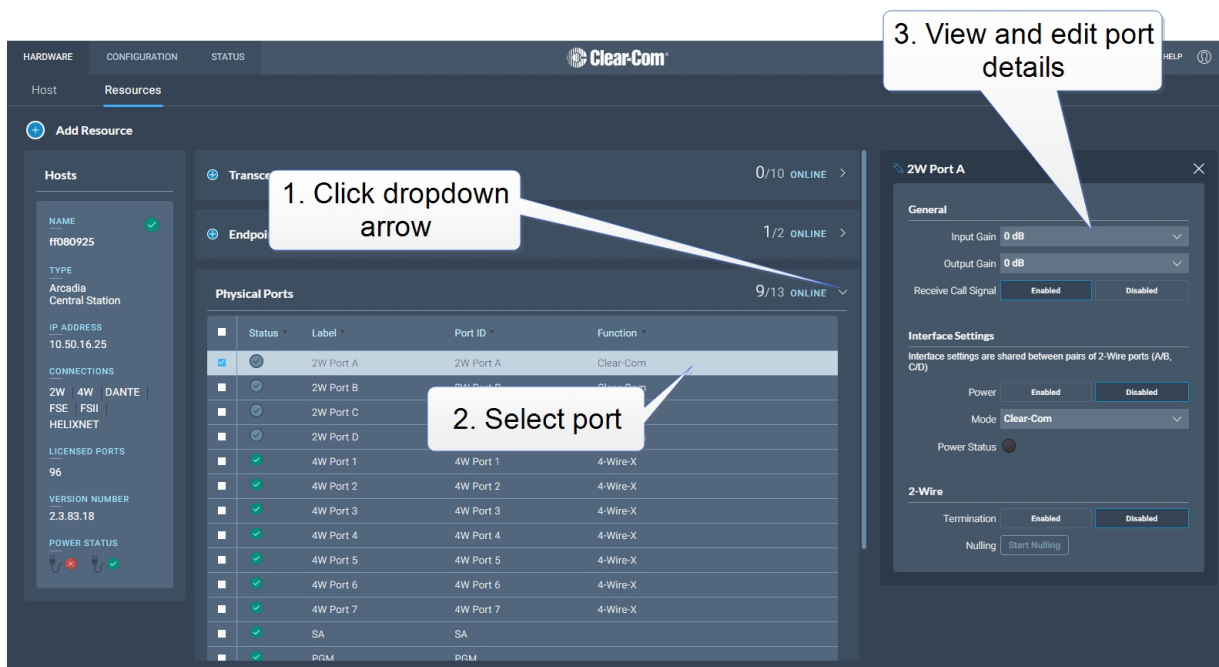

For more information see:

[Using 2-Wire Systems on page 120](#)

[Using 4-Wire Systems on page 124](#)

[Stage Announce and Program Feed on page 31](#)

Dante Ports

Click the dropdown arrow to see the Dante connections on your Arcadia Central Station. Select a port to configure it or view details.

Licensed ports

This section allows you to see and keep track of port licenses and how you are using them in your system. For example, if you know that you must have 14 wireless beltpacks connected, you can allocate 14 ports as 'Wireless' here. If you try to connect a device that you do not have a port type allocated for, the connection will be refused. Select use type for ports:

- Any (**default setting**) - in this case, any connection type is possible
- Dante
- Wireless
- HelixNet

The screenshot shows the 'Resources' page in the Clear-Com interface. On the left, there is a 'Hosts' sidebar with details for host #f080925. The main area is divided into sections: 'Transceivers' (0/10 ONLINE), 'Endpoints' (1/2 ONLINE), 'Physical Ports' (9/13 ONLINE), and 'Dante Ports' (0 ONLINE). Below these is a 'Licensed Ports' table with 96 ports in use. A 'Port 1' configuration window is open on the right, showing a 'General' tab with a 'Type' dropdown menu set to 'Any'. Three callout boxes provide instructions: '1. Click dropdown arrow' points to the dropdown arrow in the 'Type' menu; '2. Select port' points to the first row of the 'Licensed Ports' table; and '3. Select port type' points to the 'Type' dropdown menu.

ID	Allowed Endpoint	In Use By	Type
1	Any	Channel 1	HelixNet
2	Any	Channel 2	HelixNet
3	Any	Channel 3	HelixNet
4	Any	Channel 4	HelixNet
5	Any		
6	Any		
7	Any		
8	Any		

5.8 Configuring Station Settings

To configure the Arcadia Central Station, navigate to **Hardware > Host**.

Here you can:

- Configure the network
- Upgrade the Arcadia Central Station and connected resources
- Change the following wireless beltpack system settings:
 - Beltpack administration pin numbers
 - FS Edge wireless region (important for system compliance)
 - FSII battery type, if you are not using the supplied Li-ion batteries you may use Alkaline or NiMH type batteries
- Configure security settings
- Add new licenses

Click the pencil icon  to name your Arcadia Central Station .

5.9 Configuring the Network

After changing the network configuration, you must click **Apply** or [Enter] key.

For information see: [Arcadia® Central Station LAN Configuration Rules on page 54](#).

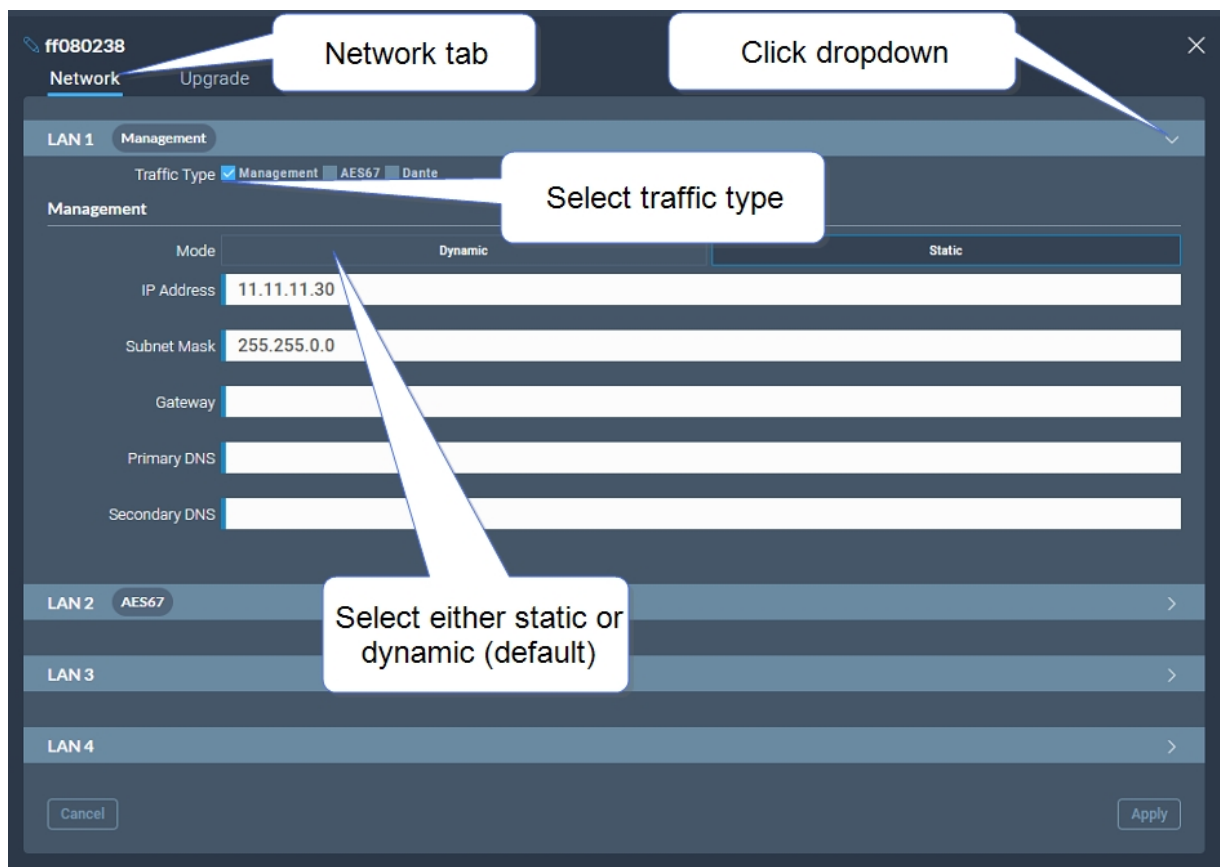

5.10 Arcadia® Central Station LAN Configuration Rules

Note: Do not plug any two LAN ports into the same LAN or VLAN. This can create a network loop affecting IP stability.

Note: Configuring/changing the AES67 IP address will cause the Arcadia Central Station to reboot.

5.10.1 AES67 Rules

- AES67 should not be on the same subnet as Management unless they are on the same LAN port (rear port)
- AES67 cannot be on the same LAN port as DANTE primary or secondary

5.10.2 IP Rules

- The IP addresses cannot be in the reserved range: 10.0.0.0-10.0.0.7
 - The subnet mask may cause an overlap with the reserved range
- The IP addresses cannot be in the LQ tunnel range 172.23.xxx.xxx
- The IP addresses cannot be in the localhost range 127.xxx.xxx.xxx
- The IP addresses cannot be in the multicast range 224.xxx.xxx.xxx-239.xxx.xxx.xxx

5.10.3 Static IP Rules

- The static IP addresses cannot be in link local range: 169.254.xxx.xxx

5.10.4 Dante Rules

- Dante primary and secondary cannot be on the same LAN port (rear connector)

5.10.5 Management Rules

- You cannot disable the Management LAN.

5.11 Setting Up the Wireless Beltpack System

Select the **Wireless** tab.

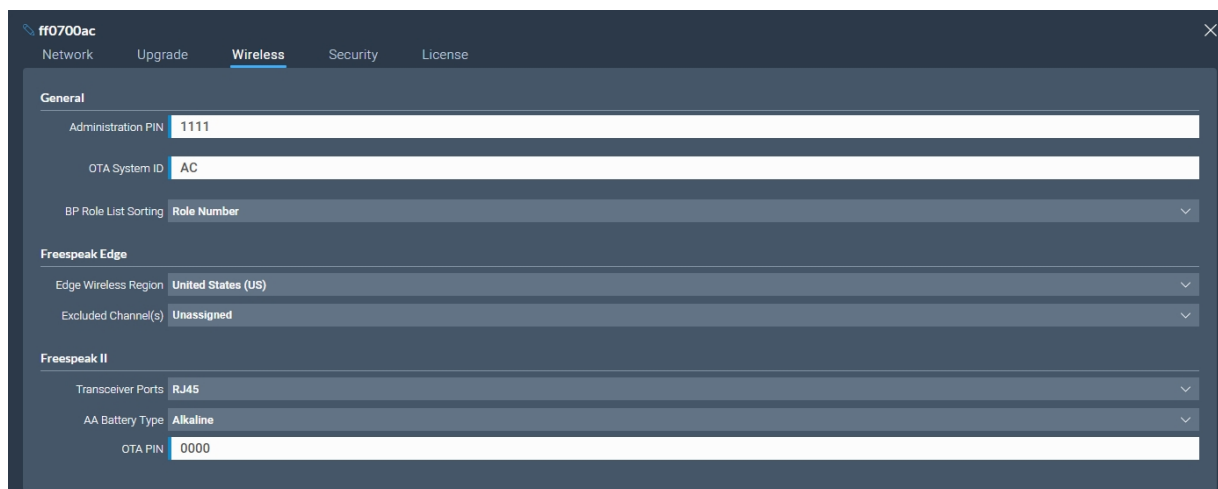

From the Wireless tab, you can set or view the following System and Station settings.

5.11.1 System

- The administration pin for your wireless system, used by the beltpack to be able to access privileged functionality

- System ID. This is used to differentiate this system's RF signals from those of other systems
- Beltpack role list sorting:
 - Role number
 - Alphabetical

5.11.2 FreeSpeak Edge

- The wireless region for your FreeSpeak Edge beltpacks. The region set here **MUST** match the hard-coded setting on your Edge transceiver or the system will not work. You will see an error flag in the **Status** page if the regions do not match. Please contact your Clear-Com representative if you have any difficulties with this.
- Select from a list of 5 GHz channels that you can exclude and prevent transceivers from using

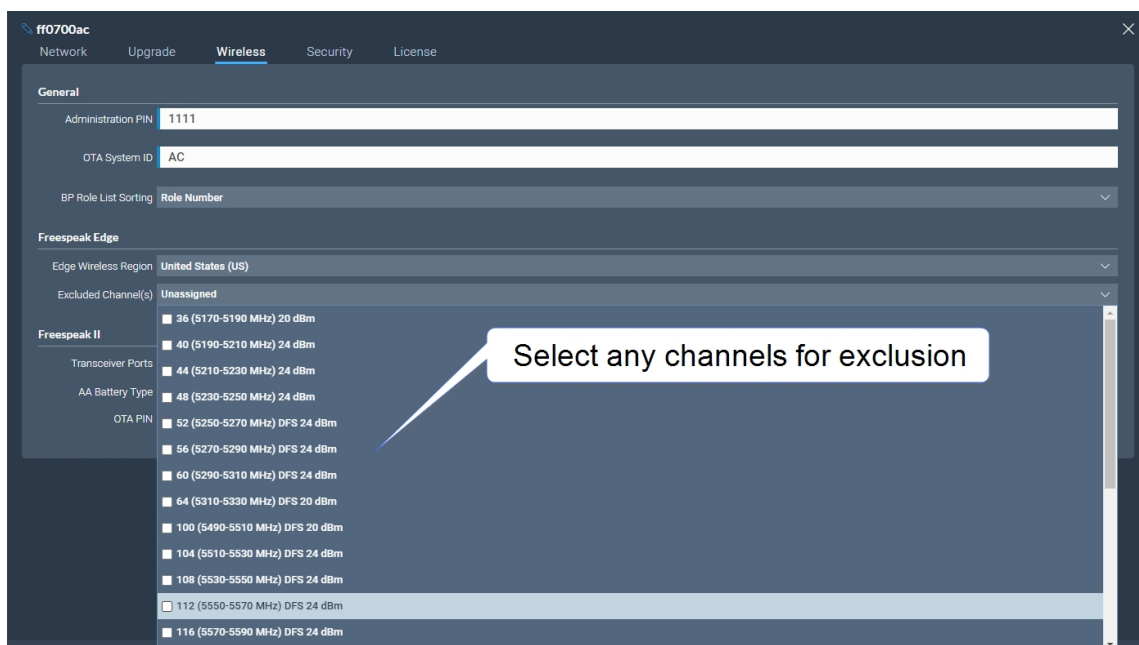

5.11.3 FreeSpeak II

- AA Battery type. You can choose not to use the Li-ion batteries supplied with the beltacks, in which case you must specify battery type here. Choose between:
 - Alkaline (AA) batteries (default setting)
 - NiMH batteries for use in settings where air pressure is an issue (for instance on an underwater site).
- The OTA pin you need for over-the-air (OTA) registration of your FreeSpeak II beltacks.

5.12 Upgrading

To upgrade the Arcadia Central Station and connected resources:

1. Select the **Upgrade** tab.
2. **Select File** then navigate to where the upgrade file is stored on your computer.
3. Select the file and when the **Upgrade** button lights, click it. This begins the upgrade process.

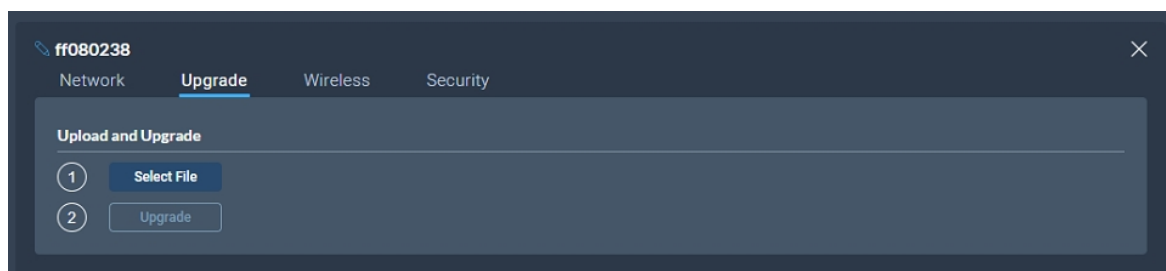

Device to upgrade	File extension
Arcadia Central Station, FS II IP TCVR, FS Edge IP TCVR	.ccf
FS II beltack, FS II E1 TCVR	.fww
FS Edge beltack	.ccu
HelixNet	See HelixNet Upgrade below

5.12.1 HelixNet Upgrade

Upgrades to the HelixNet system are included with the Arcadia software. The HelixNet system requires that all connected devices have the same firmware. Therefore, any mismatches that are detected will cause an immediate and automatic upgrade (or downgrade) to the HelixNet devices on connection. The HelixNet system will also upgrade automatically when the Arcadia Central Station is upgraded.

5.13 Configuration Page Overview

The screenshot displays the Clear-Com Configuration page. At the top, there are tabs for HARDWARE, CONFIGURATION, and STATUS. The CONFIGURATION tab is active, with sub-tabs for Channels, Groups, Roles, and Logic. The 'Channels' sub-tab is selected, showing a table of 8 channels. Channel 1 is selected, and its configuration is shown in the center, including PGM, Arcadia, Audio, Local Config, and Spots 1. On the right, the 'Ports' section shows 1/15 assigned ports, including 2W and 4W ports, SA, and PGM ports.

Status	Label	Online	Talkers	HelixNet
✓	Channel 1	5/5	1	✓
✓	Channel 2	5/5	1	✓
✓	Channel 3	1/1	0	✓
✓	Channel 4	7/7	6	✓
✓	Channel 5	0/0	0	✓
✓	Channel 6	0/0	0	✓
✓	Channel 7	0/0	0	✓
✓	Channel 8	0/0	0	✓

Status	Label	Port Id	Channel
✓	2W Port A	2W Port A	None
✓	2W Port B	2W Port B	None
✓	2W Port C	2W Port C	None
✓	2W Port D	2W Port D	None
✓	4W Port 1	4W Port 1	Channel 4
✓	4W Port 3	4W Port 3	Channel 4
✓	4W Port 4	4W Port 4	None
✓	4W Port 5	4W Port 5	Channel 4
✓	4W Port 6	4W Port 6	None
✓	4W Port 7	4W Port 7	None
✓	FromMVX	4W Port 2	Channel 2
✓	SA	SA	None
✓	PGM	PGM	Multiple (2)

The **Configuration** page of the CCM is where you configure the intercom routing aspects of your system (add audio to channels and set up talk and call keys for belt packs). It consists of four areas:

- Channels
- Roles
- Groups
- Logic (GPIOs)

The **Configuration** page enables you to:

- View existing channels and add new channels
- Add ports to channels
- View existing groups and add new groups
- View and edit roles
- View and edit General Purpose Inputs (GPIs) and General Purpose Outputs (GPOs)

5.14 Channels Page

The screenshot displays the Clear-Com Channels page. At the top, there are navigation tabs for HARDWARE, CONFIGURATION, and STATUS. Below this, there are sub-tabs for Channels, Groups, Roles, and Logic. The main content area is split into three panels:

- Channels Table:** A table with columns: Status, Label, Online, Talkers, HelloNet. It lists 8 channels (Channel 1 to Channel 8) with their respective online status and talker counts.
- Channel 1 Live State:** A central panel for 'Channel 1' showing 'HelloNet' status and a list of audio keys: PGM, Arcadia, Audio, Local Config, and Spots 1.
- Ports Table:** A table with columns: Status, Label, Port Id, Channel. It lists 15 assigned ports, including 2W ports (A, B, C), 4W ports (1-7), and FromMVX, each mapped to a specific channel or 'None'.

The Channels page enables you to view channels and add ports to channels. Audio keys are added to channels in the **Roles** page. The center panel on this screen shows the live state of audio routing.

5.15 Channels and Groups

Channels and groups are both essentially digital containers for audio sources, allowing communication between members.

5.15.1 Channels

A Channel operates as an intercom Partyline or conference. All members can talk to and listen to all other members, as long as they have keys to do so.

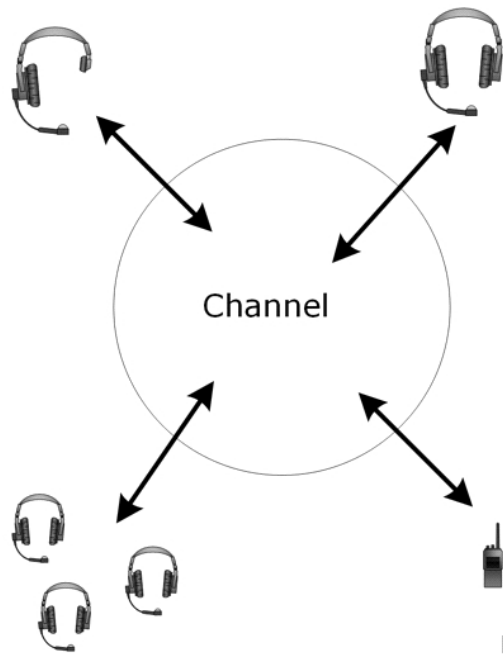

The default key behavior setting for a wireless beltpack in a Channel is **Talk and Forced Listen**. For more information, see **Key Behavior**.

5.15.2 Groups

A Group configuration enables an announcement or broadcast to a number of members at the same time.

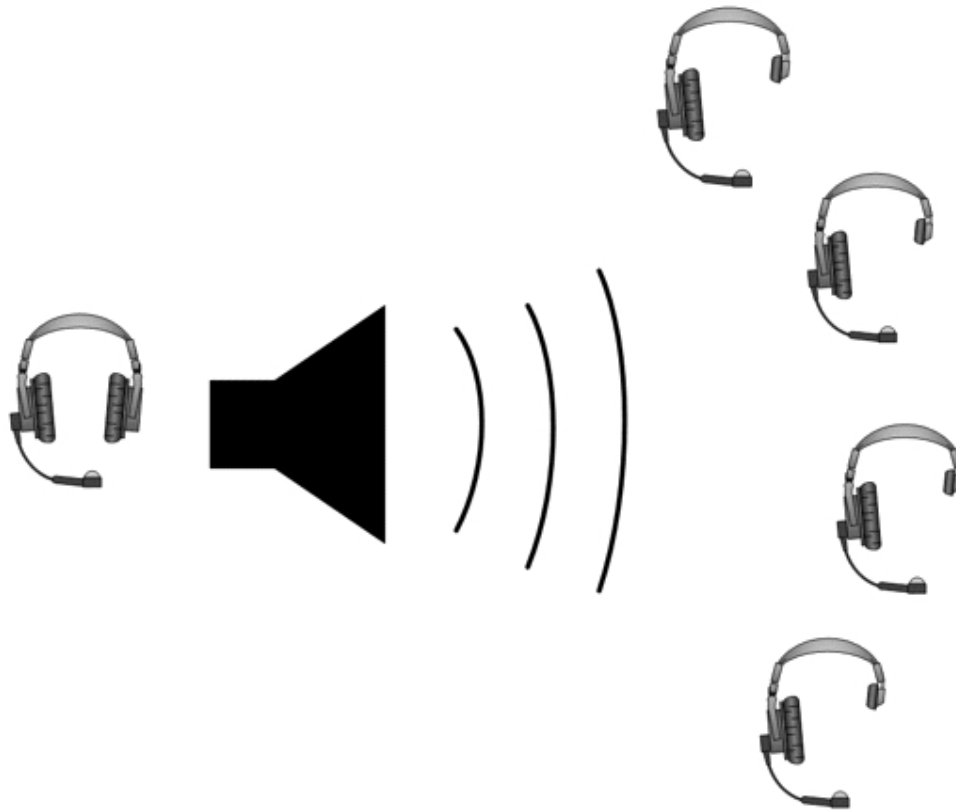

A group member can reply directly to the announcer using the **Reply** key. The other group members will not hear this.

To set up a group, you must first put the members in the Group. Then, when the members are in the Group, you can set up a key or keys to talk to it.

5.16 Managing Channels

From the **Channels** tab, you can:

- View existing channels and add or remove new channels.
- View existing ports, and add or remove ports from the channel.

To access the **Channels** screen, navigate to **Configuration > Channels**. The Channels screen appears.

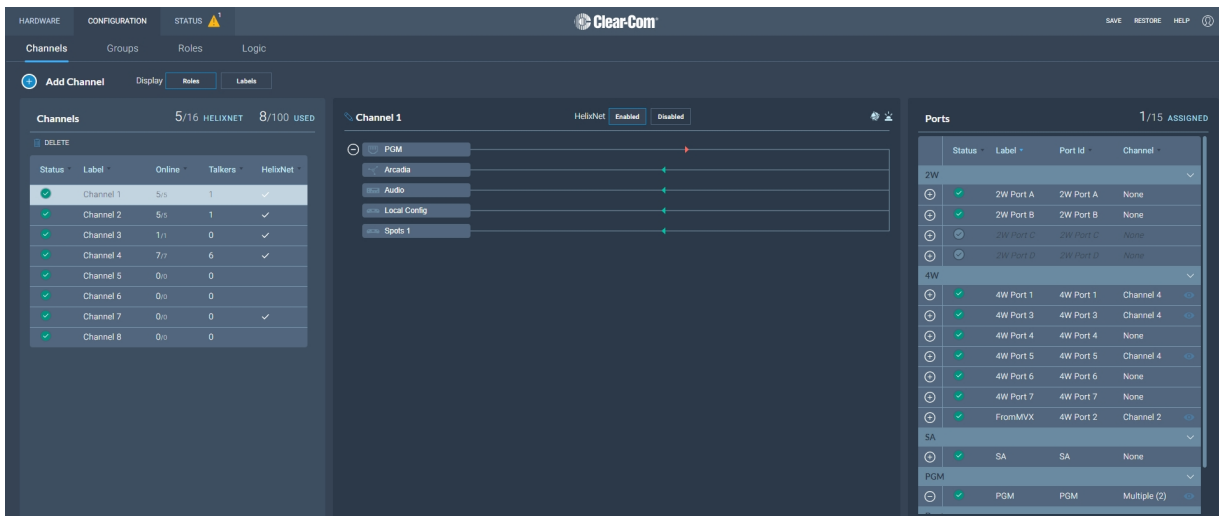

5.16.1 Viewing Information About a Channel

When you open the **Channels** screen, the left-hand panel displays a list of all the channels that are currently present. The following information is displayed for each channel.

The screenshot shows the 'Channels' screen with a table of channels. Callout boxes provide explanations for various elements:

- Click this icon to delete a channel:** Points to a minus sign icon in the top left of the Channels panel.
- The channel count indicates that eight out of a maximum of 100 channels:** Points to the '8/100 USED' text in the top right of the Channels panel.
- A green tick mark indicates that all configured ports are connected:** Points to a green checkmark in the 'Status' column of the first row.
- This is a label for the channel:** Points to the 'Channel 1' text in the 'Name' column of the first row.
- This indicates how many users are talking on this channel:** Points to the '1' in the 'Talkers' column of the first row.
- This indicates how many configured ports are connected:** Points to the '2/2' in the 'Online' column of the first row.

Status	Id	Name	Online	Talkers
✓	1	Channel 1	2/2	1
✓	2	Channel 2	0/0	0
✓	3	Channel 3	0/0	0
✓	4	Channel 4	0/0	0
✓	5	Channel 5	0/0	0
✓	6	Channel 6	0/0	0
✓	7	Channel 7	0/0	0

Status

A green tick mark indicates that all the ports that are configured for the channel are connected. Otherwise, a warning triangle is shown.

Name

This field contains a label that enables you to identify the channel.

Note: A label can contain up to 10 characters. You can edit this label from the center panel.

Online

This indicates how many of the total channel members are online.

Talkers

This indicates how many members have active talk routes on this channel.

5.16.2 Display Roles or Labels

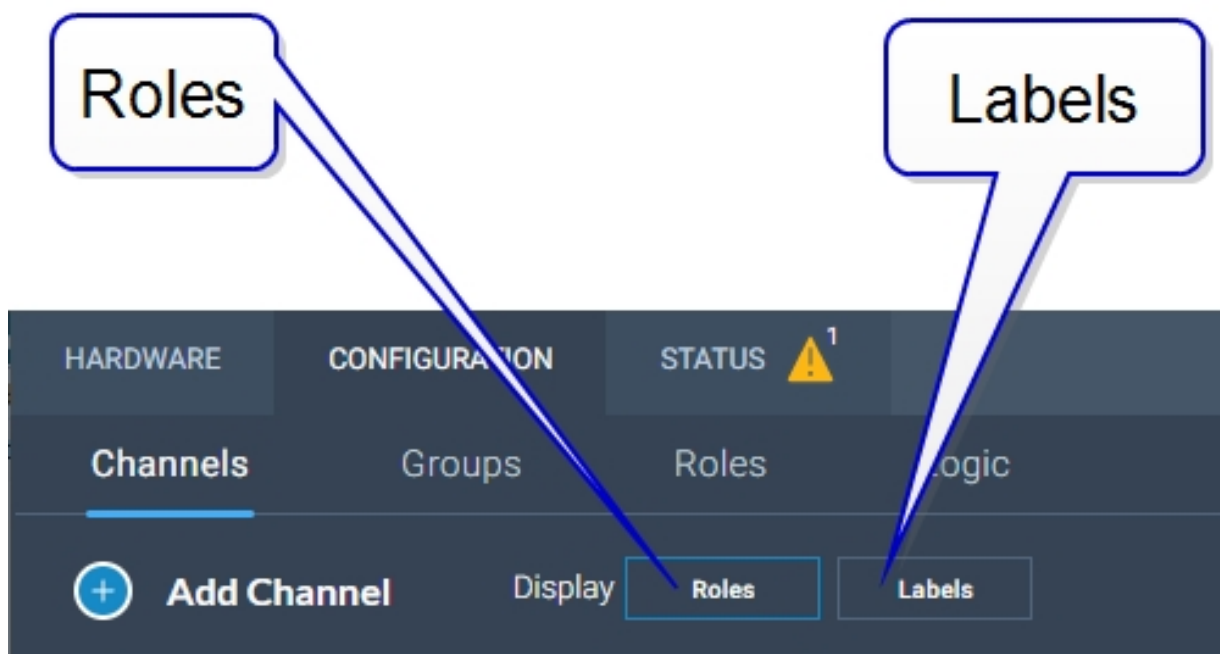

Display Roles



Display Labels

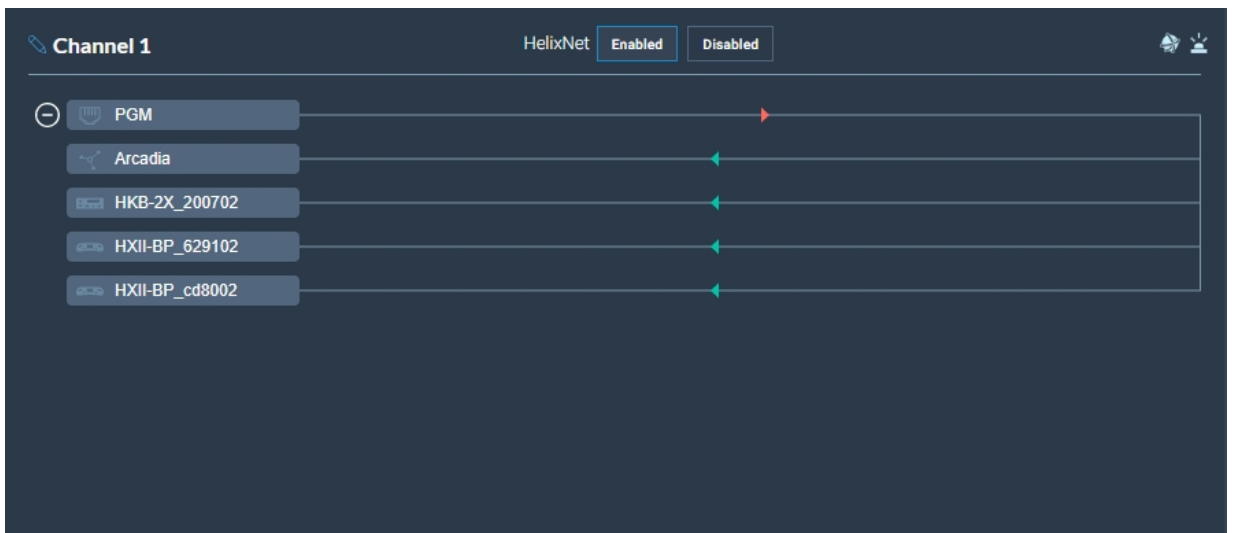

5.16.3 Adding a New Channel

To add a new channel:

1. Click the new channel icon . A new entry appears in the list of added channels.

Note: You can only add new channels up to a maximum number (100).

2. Add any required ports to the channel.

5.16.4 Adding Ports to a Channel

To add ports to a channel:

1. From the **Channel** panel, select the channel in which the port is to be added.
2. From the **Ports** panel, click the add port icon  of the port that you require.

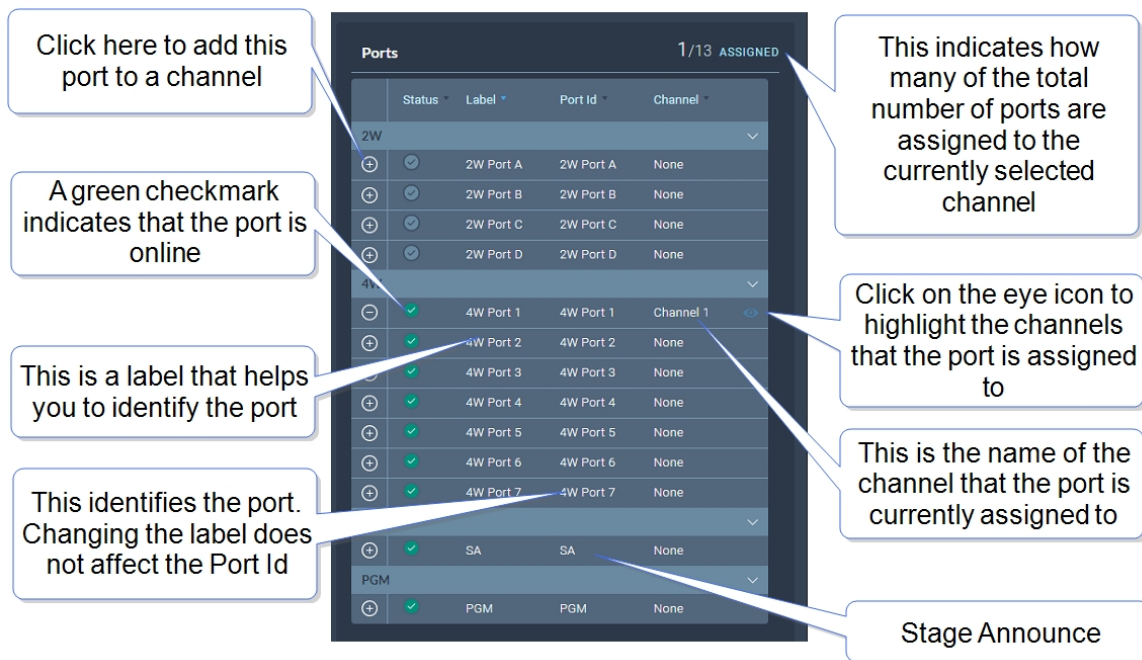

Status	Label	Port Id	Channel
2W			
	2W Port A	2W Port A	None
	2W Port B	2W Port B	None
	2W Port C	2W Port C	None
	2W Port D	2W Port D	None
4W			
	4W Port 1	4W Port 1	Channel 1
	4W Port 2	4W Port 2	None
	4W Port 3	4W Port 3	None
	4W Port 4	4W Port 4	None
	4W Port 5	4W Port 5	None
	4W Port 6	4W Port 6	None
	4W Port 7	4W Port 7	None
SA			
	SA	SA	None
PGM			
	PGM	PGM	None

1/13 ASSIGNED

Click here to add this port to a channel

A green checkmark indicates that the port is online

This is a label that helps you to identify the port

This identifies the port. Changing the label does not affect the Port Id

This indicates how many of the total number of ports are assigned to the currently selected channel

Click on the eye icon to highlight the channels that the port is assigned to

This is the name of the channel that the port is currently assigned to

Stage Announce

The port is now added to the channel, and appears in the list of ports in the center panel.



Channel 2

2W-Port A

2W-Port B

Click here to edit the channel label

Click here to remove the port from the channel

This is the label of the port

When this is lit it indicates that a call signal is active in this channel

The green arrows indicate active listen (left arrow). The red arrows indicate active talk (right arrow).

5.16.5 Removing Ports From a Channel

To remove a port from a channel:

1. From the **Channels** panel, select the required channel.

2. Click the remove icon  of the port that you want to remove.

The port is removed.

5.16.6 Deleting a Channel

To delete a channel:

1. From the **Channels** panel, select the channel that you want to delete.
2. Remove all the ports from the channel

Note: If you do not remove the ports, you will be prompted to do so in step 3.

3. Click the **More Actions** icon , and select **Delete**.

5.16.7 Enabling Channels for HelixNet

If you wish to use HelixNet in a channel, that channel must be enabled for HelixNet. By default, channel 1, 2, 3 and 4 are enabled for use with HelixNet products.

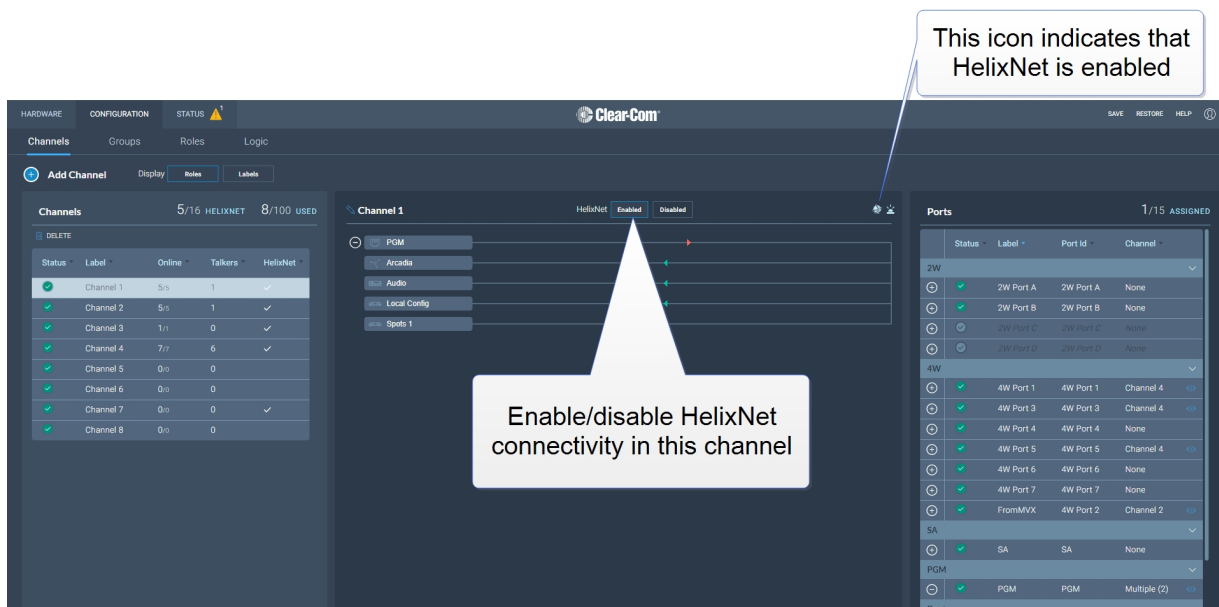

This icon indicates that HelixNet is enabled

Enable/disable HelixNet connectivity in this channel

Status	Label	Online	Talkers	HelixNet
✓	Channel 1	5/5	1	✓
✓	Channel 2	5/5	1	✓
✓	Channel 3	1/1	0	✓
✓	Channel 4	7/7	6	✓
✓	Channel 5	0/0	0	✓
✓	Channel 6	0/0	0	✓
✓	Channel 7	0/0	0	✓
✓	Channel 8	0/0	0	✓

Status	Label	Port Id	Channel
2W	2W Port A	2W Port A	None
✓	2W Port B	2W Port B	None
⊖	2W Port C	2W Port C	None
⊖	2W Port D	2W Port D	None
4W	4W Port 1	4W Port 1	Channel 4
✓	4W Port 3	4W Port 3	Channel 4
✓	4W Port 4	4W Port 4	None
⊖	4W Port 5	4W Port 5	Channel 4
⊖	4W Port 6	4W Port 6	None
✓	4W Port 7	4W Port 7	None
⊖	FromMXV	4W Port 2	Channel 2
SA	SA	SA	None
PGM	PGM	PGM	Multiple (2)

Note: A HelixNet enabled channel will consume one of your licensed ports.

5.17 Groups Page

The screenshot shows the Clear-Com Groups Page. At the top, there are navigation tabs for HARDWARE, CONFIGURATION, and STATUS. The CONFIGURATION tab is active, and the Groups sub-tab is selected. The page is divided into three main sections:

- Groups:** A table showing 1/100 USED. It has a 'DELETE' button and a table with columns: Status (green checkmark), Label (Group 1), Online (0/0), and Talkers (0).
- Group 1:** A section for the selected group, which is currently empty, displaying the message "This group is empty".
- Ports:** A table showing 0/13 ASSIGNED. It has columns: Status (green checkmark), Label, Port Id, and Group. The ports are categorized into 2W and 4W groups.

Status	Label	Port Id	Group
2W			
⊖	2W Port A	2W Port A	None
⊖	2W Port B	2W Port B	None
⊖	2W Port C	2W Port C	None
⊖	2W Port D	2W Port D	None
4W			
⊖	4W Port 1	4W Port 1	None
⊖	4W Port 2	4W Port 2	None
⊖	4W Port 3	4W Port 3	None
⊖	4W Port 4	4W Port 4	None
⊖	4W Port 5	4W Port 5	None
⊖	4W Port 6	4W Port 6	None
⊖	4W Port 7	4W Port 7	None
SA			
⊖	SA	SA	None

The Groups Page allows you to view Groups and add ports to Groups. Roles are added to Groups in the **Roles** page.

5.18 Managing Groups

From the **Groups** tab, you can:

- View existing groups and add or remove new groups.
- View existing ports, and add or remove ports from the groups.

Note: *Beltpacks are added to Groups in the Roles page.*

To access the **Groups** screen, navigate to **Configuration > Groups**. The Groups screen appears:

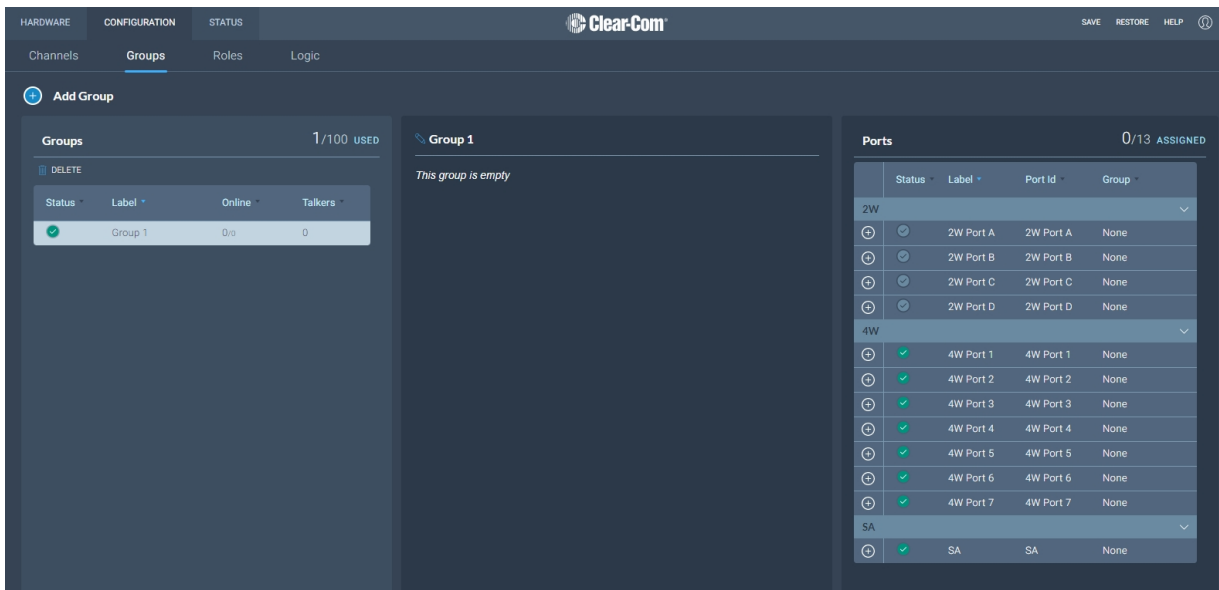

5.18.1 Viewing Information About a Group

When you open the **Groups** screen, the left-hand panel displays a list of all the groups that have been created. The following information is displayed for each group.

Status	Id	Name	Online	Talkers
✔	9	Group 1	4/4	1
✔	10	Group 2	0/0	0

Click this icon to delete a group

A green tick mark indicates that all configured ports are connected

This indicates how many users are talking on this group

The group count indicates that two out of a maximum of 100 groups are present

This is a label for the group

This indicates how many configured ports are connected

Status

A green tick mark indicates that all the ports that are configured for group are connected. Otherwise, a warning triangle is shown.

Name

This field contains a label that enables you to identify the group.

Note: A label can contain up to 10 characters. You can edit this label from the center panel.

Online

This indicates how many of the total group members are online.

Talkers

This indicates how many FS II beltpacks or logic-routed ports have active talk routes on this group.

5.18.2 Adding a New Group

To add a new group:

1. Click the new group icon . A new entry appears in the list of added groups.
***Note:** You can only add new groups up to a maximum number (100).*
2. You can now add any required ports and members to the group.

5.18.3 Adding Ports and Roles to a Group

To configure a group you must first put the members in the group. These can be ports and/or roles. When you have done this you will configure a talk key to the group (group administrator).

Adding Ports to a Group

1. From the **Group** panel, select the group in which the port is to be added.
2. From the **Ports** panel, click the add port icon  of the port that you require.

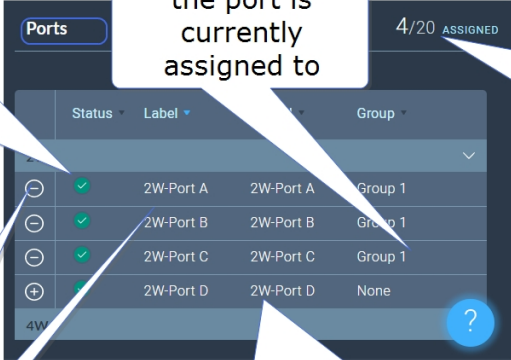

The screenshot shows a 'Ports' panel with a table of port assignments. The table has columns for Status, Label, Port, and Group. The first three rows show ports assigned to 'Group 1', each with a green tick in the Status column. The fourth row shows a port assigned to 'None'. A callout box points to the '+' icon in the first column of the fourth row, indicating it is used to add a port to a group. Another callout points to the 'Group 1' text in the Group column of the first row, indicating it is the current group assignment. A third callout points to the '4/20 ASSIGNED' text at the top right, indicating the total number of ports assigned. A fourth callout points to the eye icon in the first column of the first row, indicating it is used to highlight groups. A fifth callout points to the '2W-Port A' text in the Label column, indicating it is a label for the port. A sixth callout points to the '2W-Port A' text in the Port column, indicating it identifies the port and that changing the label does not affect the Port Id. A seventh callout points to the green tick in the Status column of the first row, indicating it means the port is online. An eighth callout points to the warning triangle icon in the first column of the first row, indicating it appears if the port is not online.

Status	Label	Port	Group
✔	2W-Port A	2W-Port A	Group 1
✔	2W-Port B	2W-Port B	Group 1
✔	2W-Port C	2W-Port C	Group 1
+	2W-Port D	2W-Port D	None

The port is now added to the group, and appears in the list of ports in the center panel.

Adding Roles to a Group

1. In the **Roles** page, select the role you wish to add to the group.
2. On the left side of the screen, select **Group Membership**.

Group Membership

Group Membership **Unassigned** 

Add role to a group

Headset

Limiters **0 dB** 

Sidetone Gain **-12 dB** 

Sidetone Control **Tracking** **Non-Tracking** **Disabled**

Headphone Detect **Enabled** **Disabled**

Headset Mic Type **Dynamic** **Electret**

Configuring a Talk Key to the Group

1. In the **Roles** page, select the role you want to talk to the group.
2. Configure a talk key to the group (Talk Only)

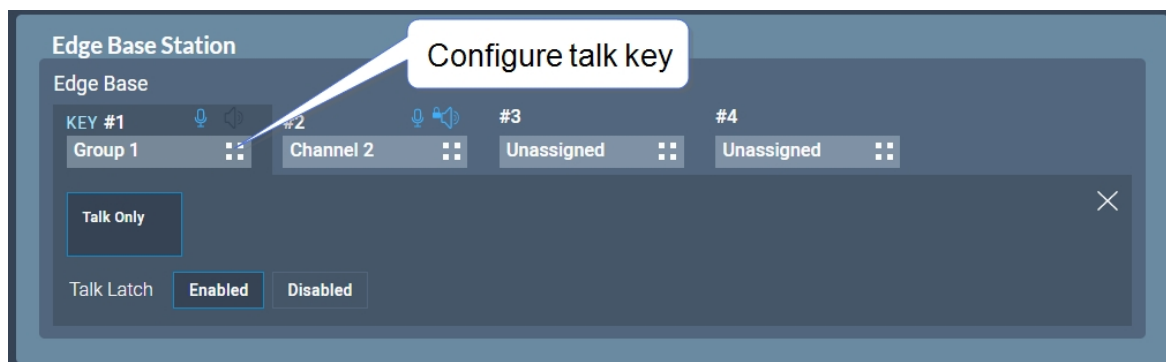

3.

When you have configured members and a talk key to a group, you will see the group by selecting it in the **Groups** page. The group administrator will talk to the whole group. The group members can talk directly back to the group administrator using the **Reply** key. This communication will not be broadcast to the group, only the administrator will hear.

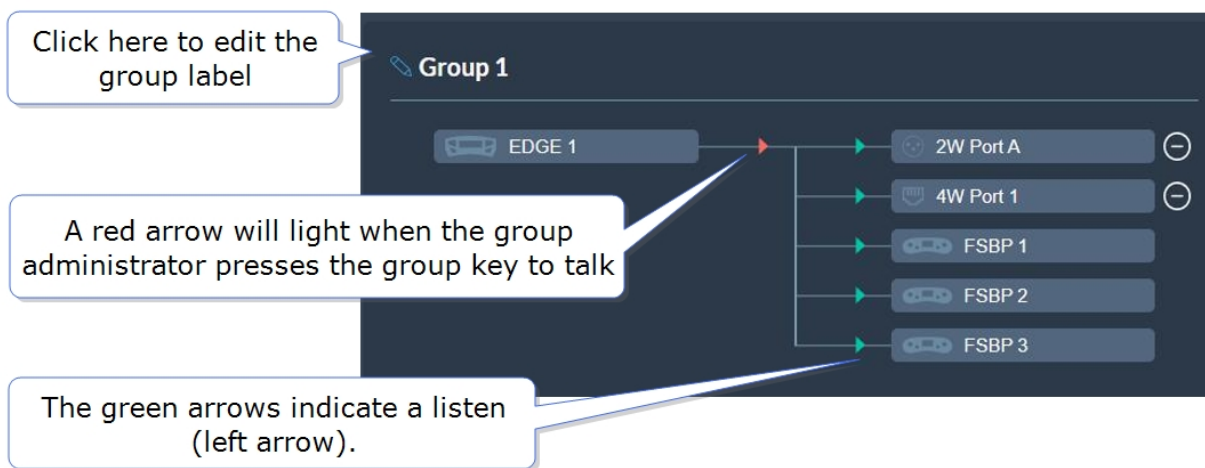

5.18.4 Removing Ports from a Group

To remove a port from a group:

1. From the **Groups** panel, select the required group.

2. Click the remove icon  of the port that you want to remove.

The port is removed.

5.18.5 Deleting a Group

To delete a group:

1. From the **Groups** panel, select the group that you want to delete.
2. Remove all the ports from the group

Note: *If you do not remove the ports, you will be prompted to do so in step 3.*

3. Click the trash can icon. The group is deleted.

5.19 Roles Page

The **Roles** page enables you to create roles for the devices in your intercom system.

Roles are made for:

- The Arcadia Central Station
- FreeSpeak II beltpacks
- FreeSpeak Edge beltpacks
- HelixNet beltpacks
- HelixNet remote stations
- HelixNet speaker stations

A role can be made that can be used with either an FS II beltpack or an FS Edge beltpack (this role can only be used on one beltpack at any one time).

Note: *FreeSpeak roles work on a 1:1 basis, each beltpack must have a unique role. HelixNet roles work on a 1: many basis, a HelixNet role can be used by many user stations. .*

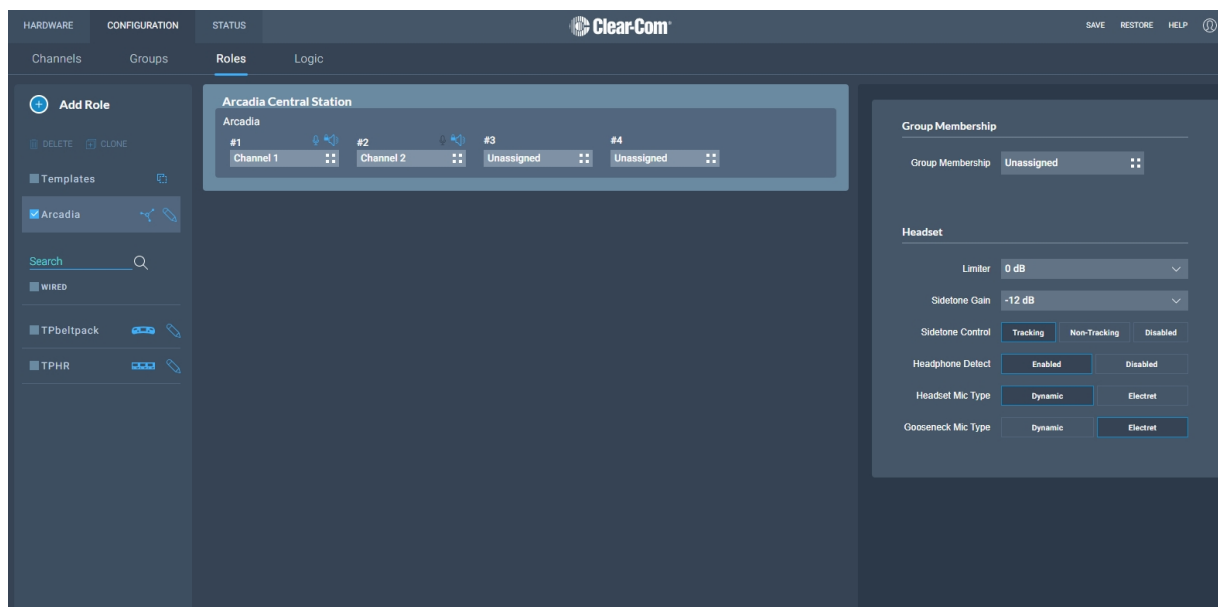

The **Roles** page of the CCM enables you to:

- View, edit, add and delete roles.

5.20 Managing Roles

Roles are used to control the audio configuration and other settings for beltpacks and other devices (including the Arcadia Central Base Station).

From the **Roles** page, you can view, add, edit, clone or delete roles.

When creating roles, roles can be:

- Added (role is based on the template role)
- Cloned (role is based on any selected role)

When working with FreeSpeak II, a role must be created for each beltpack or device that you use. This relationship is 1:1. If you want the same settings for multiple beltpacks, you may decide to clone an existing role.

When working with HelixNet, a role can be used many times. This relationship is 1:many. In HelixNet, roles are available for: beltpacks, remote stations, speaker stations.

5.20.1 Viewing Roles

To view roles, navigate to **Configuration > Roles**. The following screen appears.

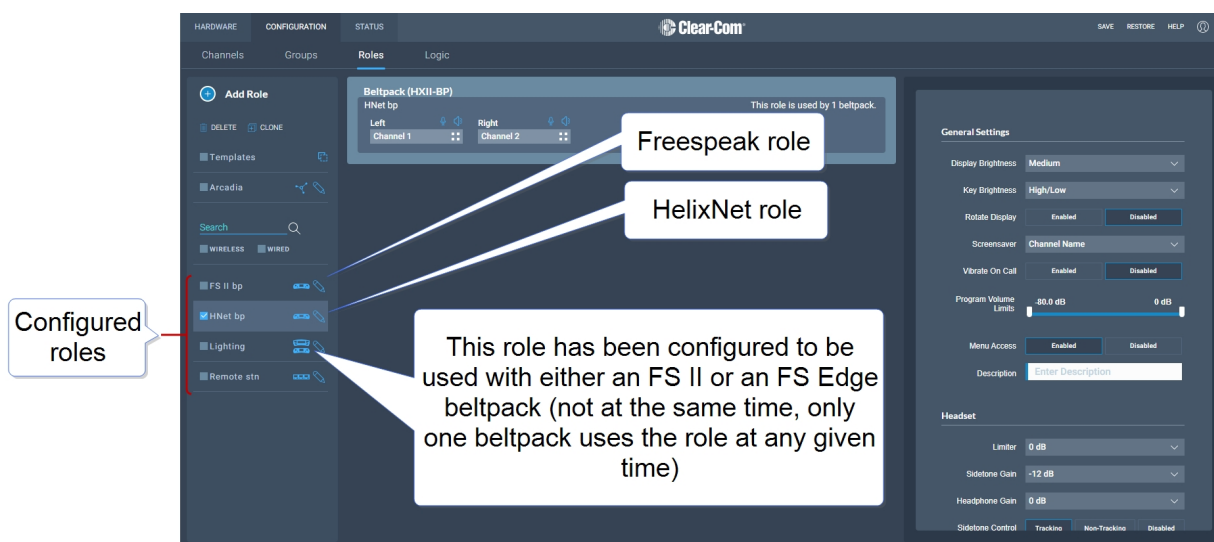

A list of roles appears on the left-hand side of the screen.

5.20.2 Role Templates

When you add roles, a new role is always created from a template role. Template roles are editable. If you edit a template role, any new roles created from it have the edited settings.

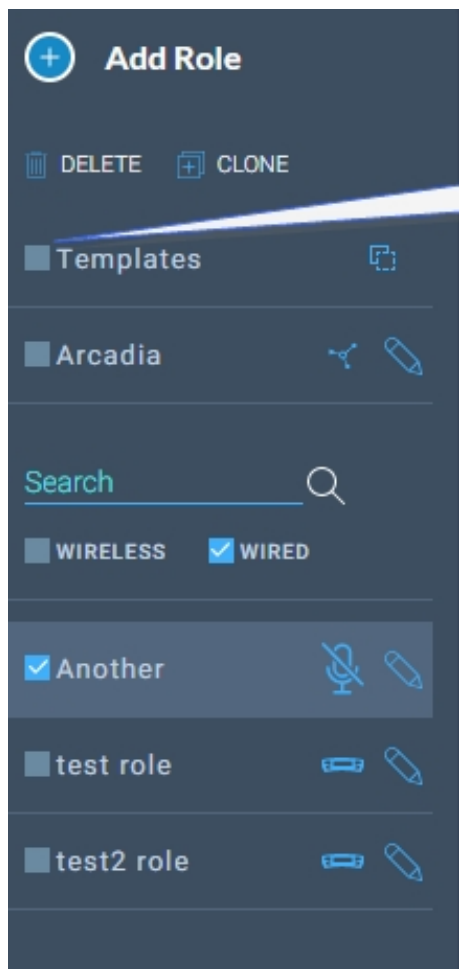

Select a role template to edit the settings.

To reset template roles to default settings, reset the Arcadia Central Station to factory defaults.

Note: *The role templates you see depend on which feature licenses you have on the Arcadia Central Station.*

5.20.3 Adding Roles

To add roles:

1. Navigate to **Configuration > Roles**.

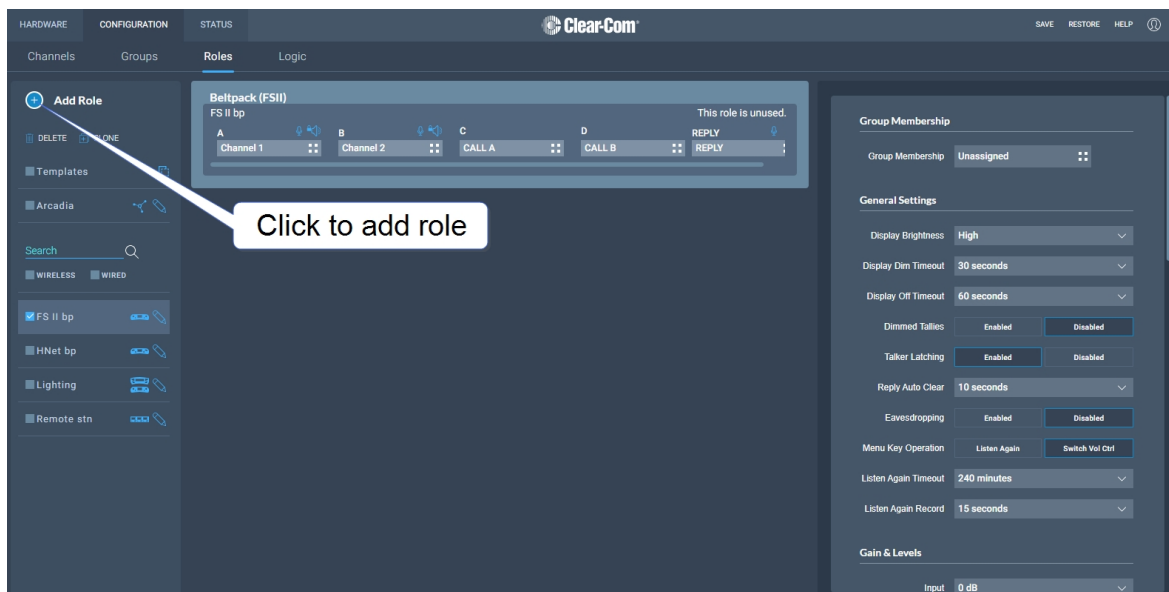

2. Click **Add Roles**. The following screen appears.

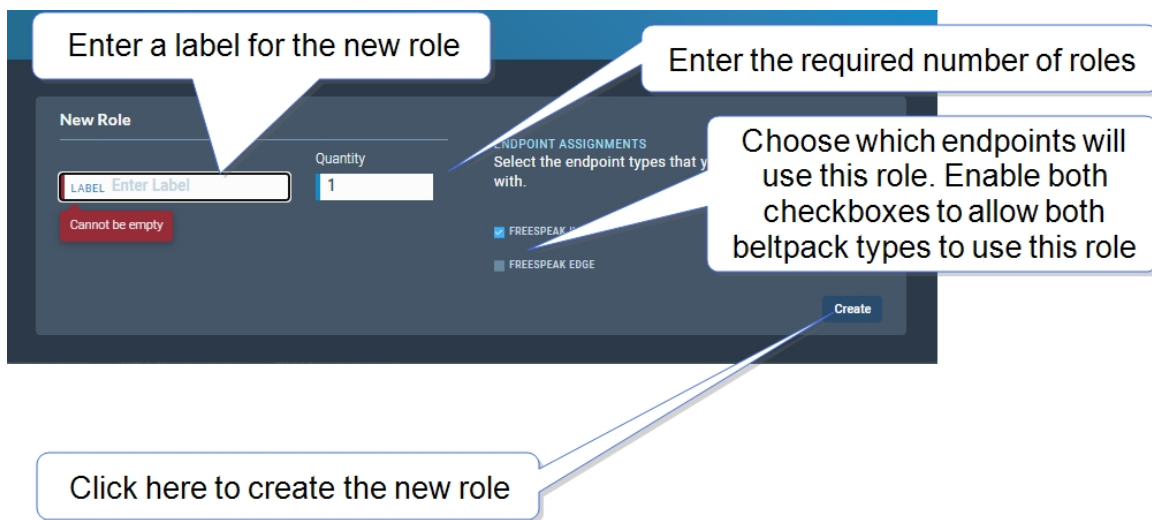

3. Enter a label for the role, the number of roles required and choose which endpoints will use this role (FS II, FS Edge or both). Only one beltpack can use the role at a given time.

Note: When creating multiple roles, the system will add an incrementing numerical suffix to the role name. Roles names must be unique.

Note: You can also edit the label and endpoint assignments from the icons that appear beside each role in the left-hand side of the screen.



4. Click **Create**. The new role appears in the list of roles in the left-hand side of the **Roles** screen.

5.20.4 Editing Role Key Assignment

1. Navigate to **Configuration > Roles** and select required role on the left of the screen.
2. Click on the small white squares.

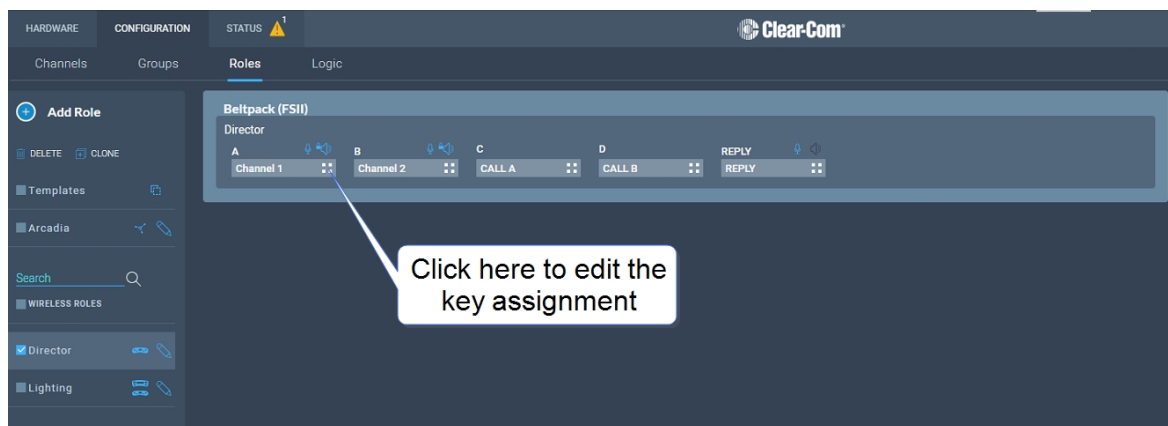

The key assignment screen appears.

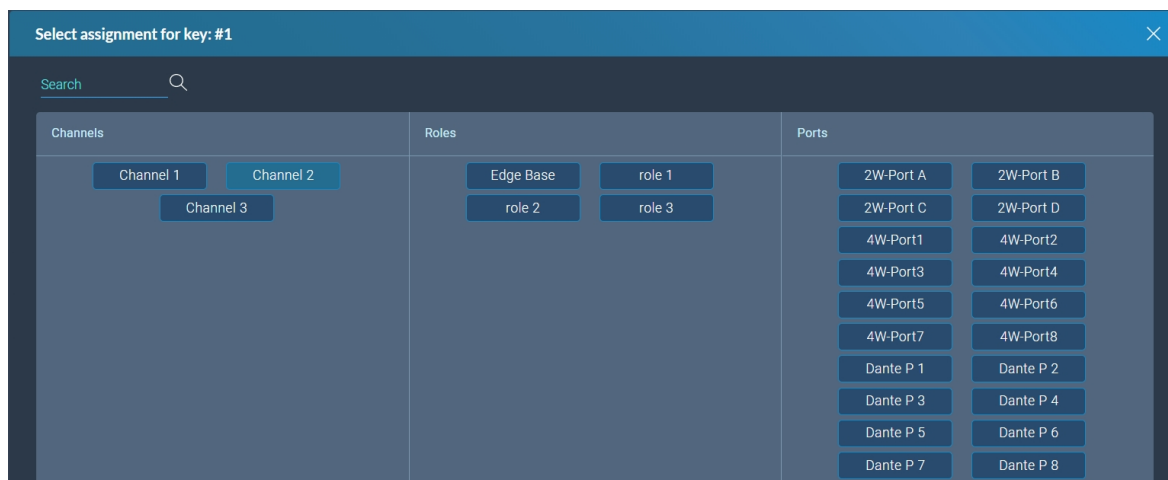

3. Click to select the required audio source.

5.20.5 Configuring Role Settings

To configure the settings for a role:

1. Navigate to **Configuration > Roles**, and select the required role from the list of roles in the left-hand side of the screen.
2. From the **Settings** panel on the right-hand side of the screen, scroll to the required setting.
3. Edit the setting as required.

5.20.6 Cloning Roles

To clone roles:

1. Navigate to **Configuration > Roles**, and select the role that you wish to clone from the list of roles in the left-hand side of the screen.
2. Click **CLONE**.

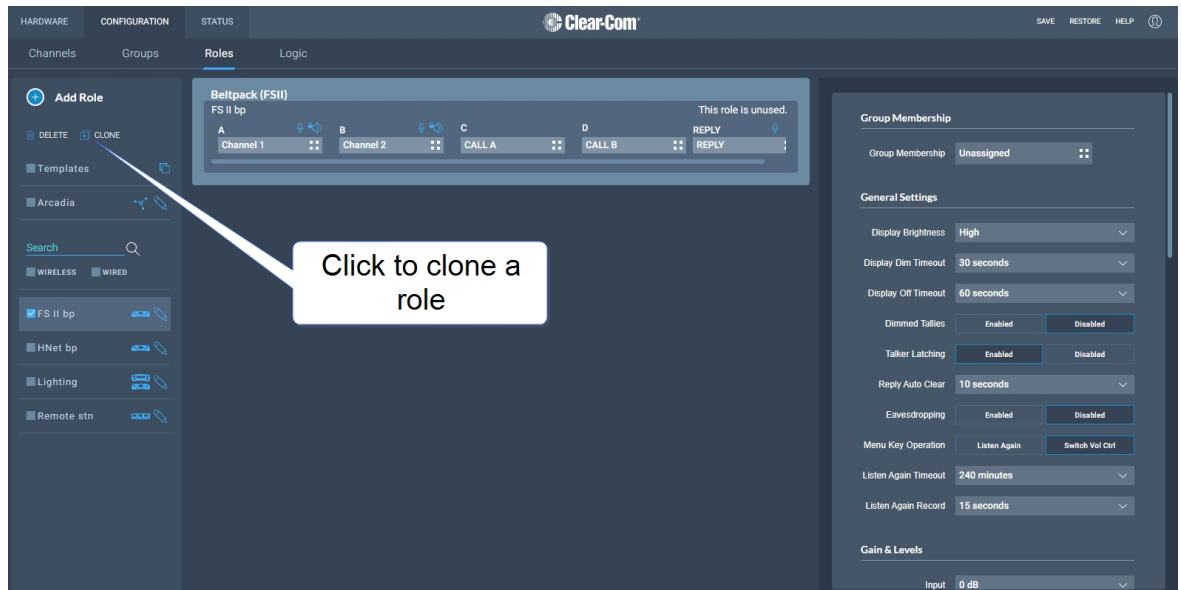

The role is cloned and added to the list of roles in the left-hand side of the screen.

5.20.7 Deleting Roles

To delete roles:

1. Navigate to **Configuration > Roles**, and select the role that you wish to delete from the list of roles in the left-hand side of the screen.
2. Click **DELETE**.

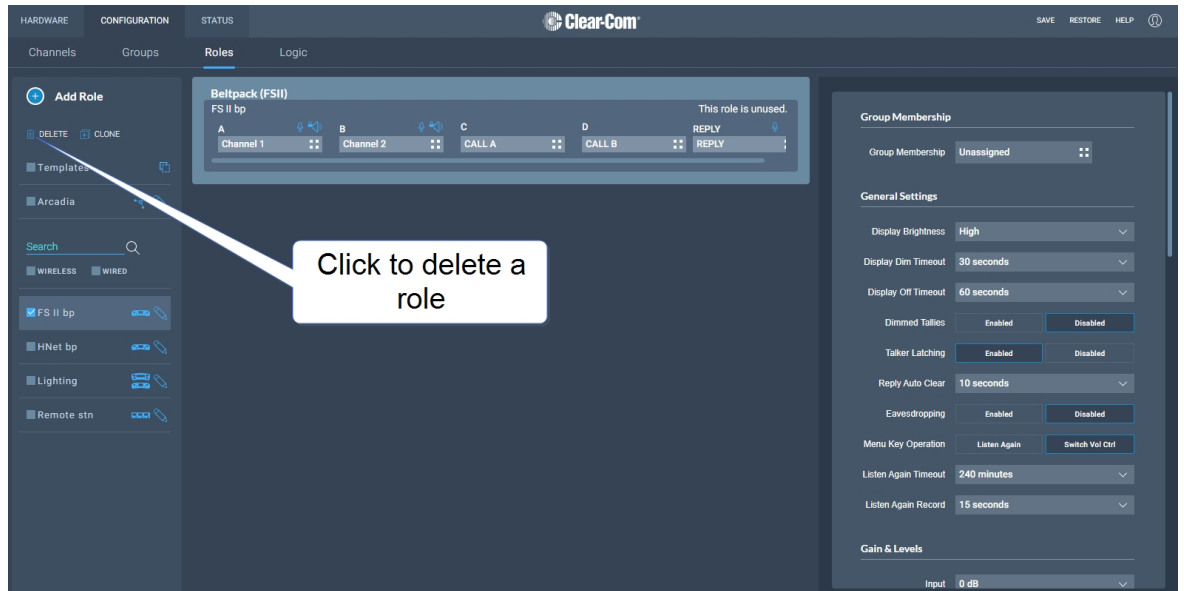

The role is deleted and removed from the list of roles in the left-hand side of the screen.

5.20.8 Setting Key Behavior

Audio keys can be set to different Talk and Listen states. These key behavior states apply to the keys on the Arcadia Central Station and beltpacks. Key behavior is configured in the **Roles** tab in the CCM. See [Managing Roles on page 74](#).

Key Behavior Options	Resulting Audio Behavior
Talk-Only	Press key to talk. Key only controls talk.
Listen-Only	Press key to listen. Key only controls listen.
Talk and Listen	Press key to talk and listen.
Dual Talk and Listen (beltpacks only)	Press key to talk and listen. Listen latches on or off according to preference (quick tap to latch). The user can push and hold (PTT) to activate talk.
Force Listen	Permanent listen.
Talk and Forced Listen	Permanent listen, push key to talk.
Force Talk and Force Listen (beltpacks only)	Permanent listen and talk.

5.20.9 Fixed Roles

When a role is fixed to a beltpack, a beltpack user is forced to use that role. If a role is not fixed to a beltpack, the user can chose from any available roles.

When you register beltpacks via USB cable to the Station, an editable fixed role is created and applied to the beltpack.

Roles can be fixed/unfixed in the CCM.

Navigate to: **Hardware > Resources > Endpoints** (select the down arrow to see all connected Endpoints). Select an Endpoint (beltpack) by clicking it. Click to fix/unfix or change the role for this beltpack.

The screenshot displays the Clear-Com software interface for configuring resources on a host. The main window is titled "Resources" and shows a list of endpoints under the "Endpoints" section. A callout box labeled "Select beltpack" points to the row for endpoint "HXII-BP_c29302". A second callout box labeled "Role" points to the "TPbeltpack" role assigned to this endpoint. A third callout box labeled "Unpair or deregister beltpack" points to the "Unpair" button in the "Maintenance" section of the endpoint's configuration panel.

Host Resources Summary:

- Hosts:** f080925 (Online)
- Transceivers:** 1/2 ONLINE
- Endpoints:** 1/2 ONLINE
- Physical Ports:** 9/13 ONLINE
- Dante Ports:** 0/0 ONLINE
- Licensed Ports:** 4/96 IN USE

Status	Label	ID	Role	Type
🔄	HXII-BP_5db302	5DB302	Local Config	HBP-2X
✅	HXII-BP_c29302	C29302	TPbeltpack	HBP-2X

Endpoint Configuration (HXII-BP_c29302):

- General:** Type: HBP-2X, ID: C29302, Select Role: TPbeltpack
- Version:** 4.2.68.0
- Maintenance:** Unpair this endpoint from the station to free up any assigned resources preventing automatic reconnection.

5.21 Logic Page

The Arcadia Central Station offers six fully configurable GPIOs, increasing the range and possible uses of controls and relays.

- 2 x GPIs. These can be used, for example, to allow the station operator to open an audio route to a Channel using a foot switch, or to route a program feed to a Channel, Group or beltback when an on-air light comes on.
 - Up to 10 different audio routes can be generated on each GPI.
- 4 x GPOs. The most common uses for output relays are to turn on an on-air light, connect to a radio, or send an input to an external audio console.
 - Up to 10 different actions can be generated on each GPO.
- You can also set up extended control sequences in the **Control Logic** section.

Relays (GPOs) and GPIs are configured in the **Configuration > Logic** page of the Core Configuration Manager (CCM) and can be viewed and tested on the **Status > Logic** page.

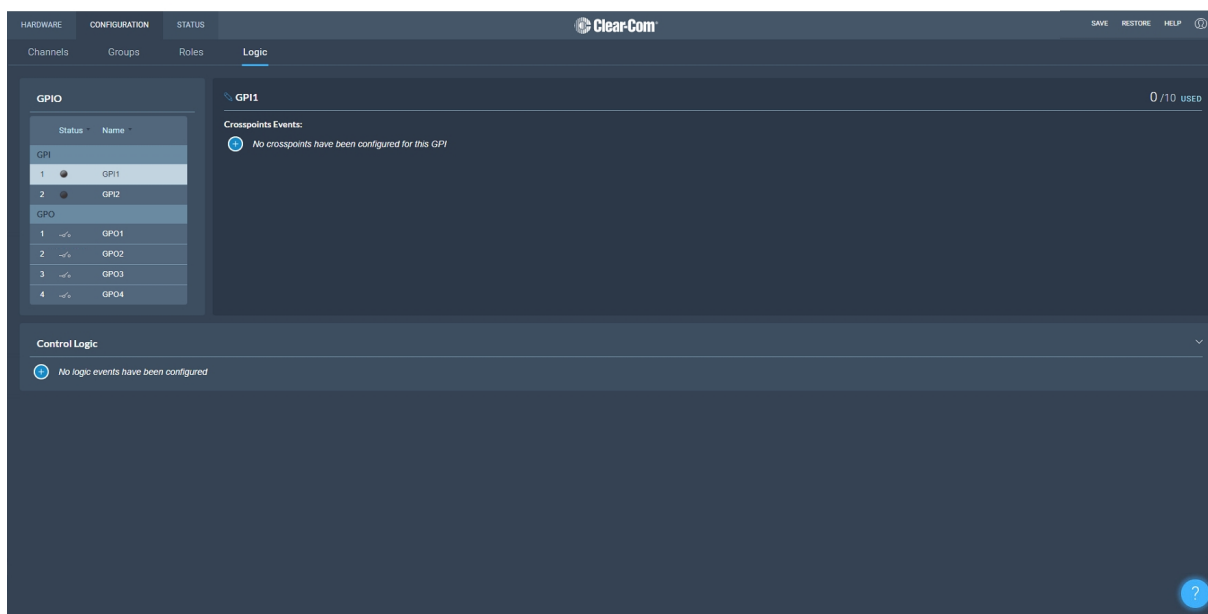

5.22 Setting up GPIOs and Logic Events

5.22.1 Overview

- 2 x GPIs
- 4 x GPOs
- Unlimited Logic Events

- Each GPI/GPO hosts up to 10 different events or actions. These actions can be turned off or on in the **Status > Logic** page of the CCM.
- 2 x DB 9F connectors on the rear of the Arcadia Central Station (**C**). See [Rear Panel Connectors and Indicators on page 27](#).
- For DB 9F pinouts, see [Appendix A: Pinouts on page 145](#)

5.22.2 Examples of GPIs

On an input from an external device, an audio route can be established between two entities.

- If an on-air light comes on, the program feed (**PGM**) can be routed to a Channel or beltpack.
- Use a footswitch to allow the station user to open an audio route to a Channel.
- On an input from a two-way radio, an audio route can be established to a channel (the radio talks to the channel).

5.22.3 Examples of GPOs

GPOs are triggered (sent to an external device) when a **Talk**, **Talk & Listen** or a **Call** comes into a named entity.

- When someone talks to stage announce, an output relay (GPO) is sent to the external stage announce speaker.
- When someone talks to a channel labeled Radio, an output is sent to a 2-way radio.
- When a call signal (**Call**) comes into a channel, and output is sent to turn on an on-air light.

5.22.4 Examples of Logic Events

- An output can be triggered on a crosspoint activation (when someone presses a talk key).
- An input can be used to trigger a call signal.



5.22.5 Configuring GPIs

This example opens a talk route from the Arcadia Central Station to a Channel when an input occurs on GPI1 (for instance, from a footswitch).

Navigate to **Configuration > Logic**.

1. On the left panel, click GPI1 to select it.



2. Click the Add button  in the center panel.
3. Click the Options button  to select a **Source**. Select **Arcadia**.
4. Click the Options button  to select a **Destination**. Select the required Channel.
5. Click the blue check mark.
6. To label the GPI, click the pencil icon.
7. To test the GPI, or turn it on and off, navigate to **Status > Logic**. See: [Logic Page on page 84](#).

5.22.6 Configuring GPOs

In this example you send an output trigger (for example to an external stage announce speaker) on GPO1 when a beltpackTalk is activated on the stage announce (SA) 4-wire port.

1. Navigate to **Configuration > Logic**.



2. On the left panel, click GPO1 to select it.

3. Click the Add button  in the center panel.

4. Click the Options button  to select a **Key Target**. Select stage announce (SA).

5. In this case, the **On Behavior** field defaults to **Talk Only**.

6. Click the blue check mark.

7. To label the GPO, click the pencil icon.

8. To test the GPO, navigate to **Status > Logic**. See [Logic Page on page 84](#).

5.23 Status Page

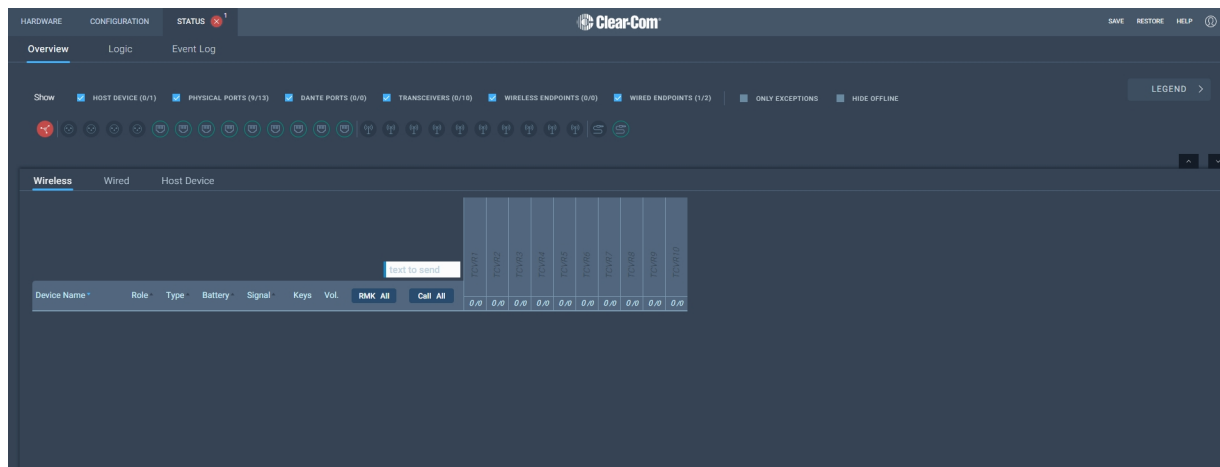

From the **Status** page of the CCM, you can view the status of all the resources that are connected to the Arcadia® Central Station. These include:

- Transceivers (IP and E1)
- Beltpacks
- Interface ports

Here you will see error and warning states.

Note: *Error states are used exclusively to indicate that audio via this resource is not working.*

You can quickly see if entities are:

- Offline
- Online
- Initializing

5.24 Monitoring System Status

You can monitor your system using the following features of the CCM:

- Overview
- Event Log
- Logic

5.24.1 Overview

To see the **Overview** screen, navigate to **Status > Overview**. The following screen appears.

The screenshot shows the Clear-Com CCM interface. At the top, there are tabs for HARDWARE, CONFIGURATION, and STATUS. The STATUS tab is active, and the Overview sub-tab is selected. Below the tabs, there are filters for various resource types: HOST DEVICE (1/1), PHYSICAL PORTS (9/13), DANTE PORTS (0/0), TRANSCIVERS (0/10), WIRELESS ENDPOINTS (0/0), WIRED ENDPOINTS (1/2), ONLY EXCEPTIONS, and HIDE OFFLINE. A LEGEND button is also present. The main content area is titled 'Host Device' and displays details for device #1080925. It includes sections for Network (Management), General, Version, and Dante. The Network section shows IP Address 10.50.16.25, Subnet Mask 255.255.252.0, Gateway 10.50.16.1, Host name CC-ARC-00015B07-0, Primary DNS 10.50.1.51, Secondary DNS 10.50.1.151, Port LAN1, Link Status Up, and MAC 00:0e:98:08:09:25. The General section shows Status Good, Uptime 5 hours 11 minutes, and Sync source PTP. The Version section shows Version 2.3.83.29-38562 (Boot: NEP-1.1.8), Hardware Version 5.00 (FPGA: 2.3.83.29-38562) (MIXER FPGA: 0x0103) (NRF: Good), and HelixNet Version 4.3.9.0. The Dante section shows Status LOCKED, Role Follower, Reference ID 00-0e-98-ff-fe-08-00-2e (Priority 127), Local ID 00-0e-98-ff-fe-08-09-29 (Priority 127), Offset from Reference 224 ns (max 445 ns), and Max Data Rate 11.678 → 44.40.

The **Overview** screen consists to two sections. There is an upper section that displays a list of system icons representing the ports, transceivers and endpoints and a lower section that gives detailed information about each connected device and about the Arcadia Central Station.

Note: *There is currently no detailed status for 2W, 4W and Dante.*

5.24.2 System Icons

Each icon is color-coded to give an easily accessible view of the status of each entity.

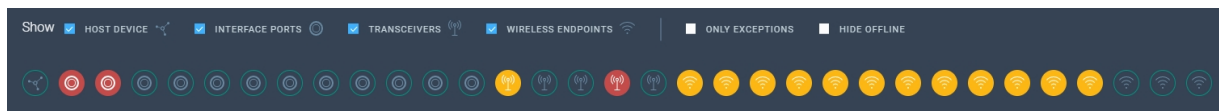

The following legend is used to indicate the status of each entity.

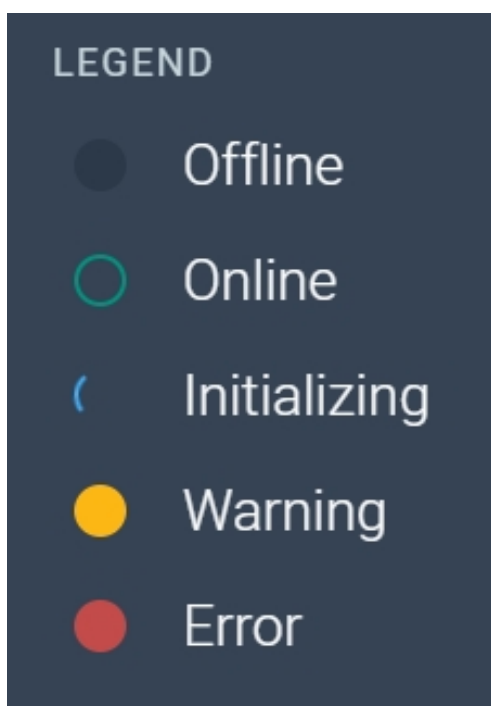

5.24.3 Monitoring Wireless Devices

Navigate to **Status > Overview > Wireless**. This section of the **Overview** screen lists all the wireless devices connected to your system, and gives the following information for each device:

- Associated role
- Type of transceiver
- Battery level
- Signal strength
- Volume setting

- Remote Microphone Kill (RMK) button to mute all microphones connected to your system.
- Call button to send a text message to all connected devices.
- Network and PTP status of transceivers
- Reboot transceiver

Device Name	Role	Type	Battery	Signal	Keys	Vol.	RMK All	Call All	TCVR1	TCVR2	TCVR3	TCVR4	TCVR5	TCVR6	TCVR7	TCVR8	TCVR9	TCVR10	CC-TCVR-08XYF386	CC-TCVR-08XYF386	CC-TCVR-32XY0085	CC-TCVR-32XY0478	CC-TCVR-32XY0108	CC-EDGE-26XYF751	CC-EDGE-07304803
EDGE-BP-524403	Producer	FSE 5.0	[Battery Icon]	[Signal Icon]	[Keys Icon]	[Vol. Icon]	RMK	Call	0/4	0/4	0/4	0/0	0/0	2/4	0/4	0/4	0/0	0/0	0/10	0/0	0/10	1/10	2/10	2/10	0/10
EDGE-BP-524481	Actor	FSE 5.0	[Battery Icon]	[Signal Icon]	[Keys Icon]	[Vol. Icon]	RMK	Call																	
FSII-BP-16210	Ademola	FSII 1.9	[Battery Icon]	[Signal Icon]	[Keys Icon]	[Vol. Icon]	RMK	Call																	
FSII-BP-16226	Lara	FSII 1.9	[Battery Icon]	[Signal Icon]	[Keys Icon]	[Vol. Icon]	RMK	Call																	
FSII-BP-28036	Katty	FSII 1.9	[Battery Icon]	[Signal Icon]	[Keys Icon]	[Vol. Icon]	RMK	Call																	
FSII-BP-327796	Dancer	FSII 2.4	[Battery Icon]	[Signal Icon]	[Keys Icon]	[Vol. Icon]	RMK	Call																	
FSII-BP-327814	Singer	FSII 2.4	[Battery Icon]	[Signal Icon]	[Keys Icon]	[Vol. Icon]	RMK	Call																	

Transceiver details

View details. Scroll down here to reboot the transceiver.

Select a transceiver to see network, version and PTP details.

PTP details

Device Name	Role	Type	Battery	Signal	Keys	Vol.	RMK All	Call All	TCVR1	TCVR2	TCVR3	TCVR4	TCVR5	TCVR6	TCVR7	TCVR8	TCVR9	TCVR10	CC-EDGE-9726724	CC-TCVR-08XYF426	
EDGE-BP-524291	EDGE 1	FSE 5.0	[Battery Icon]	[Signal Icon]	[Keys Icon]	[Vol. Icon]	RMK	Call	0/0	0/0	0/0	0/0	0/0	0/0	0/0	0/0	0/0	0/0	2/10		
EDGE-BP-524338	EDGE 2	FSE 5.0	[Battery Icon]	[Signal Icon]	[Keys Icon]	[Vol. Icon]	RMK	Call													
FSII-BP-15901	FSII 2	FSII 1.9	[Battery Icon]	[Signal Icon]	[Keys Icon]	[Vol. Icon]	RMK	Call													
FSII-BP-16231	FSII 1	FSII 1.9	[Battery Icon]	[Signal Icon]	[Keys Icon]	[Vol. Icon]	RMK	Call													

CC-TCVR-08XYF426

Network

AES67 Admin IP 169.254.8.123
Address

AES67 Audio IP 169.254.8.128
Address

Subnet Mask 255.255.0.0
Network Mode DHCP

Version

Version 4.8.67.0
Radio Version 0107
FPGA Version v.0.6.2-b46v2.3.4-b100-c2

PTP

Status Locked
Role Slave
Master ID 00-0e-98-f1-fe-08-02-3a
(Priority 127)
Local ID 00-0e-98-f1-fe-02-fe-77
(Priority 254)
Offset from Master 20 ns (max 47 ns)
Mean Path Delay 6,600 ns +/- 3
Mean Frequency -1 ppb +/- 27

Maintenance

Monitoring Beltpack Details

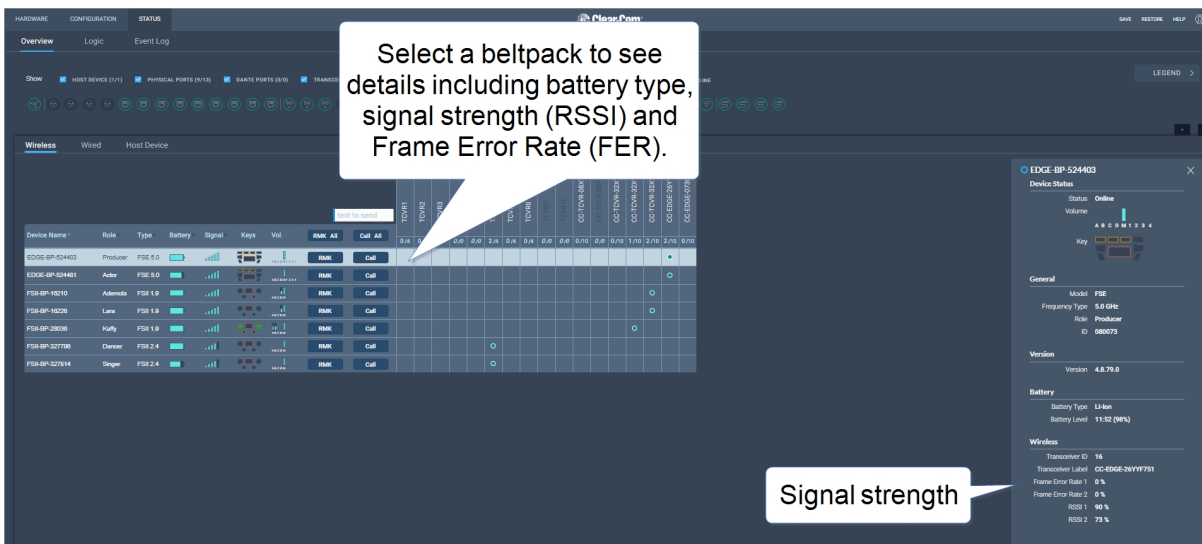

5.24.4 Monitoring Wired Devices

Navigate to **Status>Overview>Wired**. A screen appears that gives information about the HelixNet wired user stations (beltpacks, remote stations and speaker stations) and enables various procedures including:

Procedure	Information
<ul style="list-style-type: none"> Reboot Reset to Default 	<ul style="list-style-type: none"> Status ID Role Firmware version

From this page you can also **RMK all**. This will close the mic on all beltpacks, both wired and wireless.

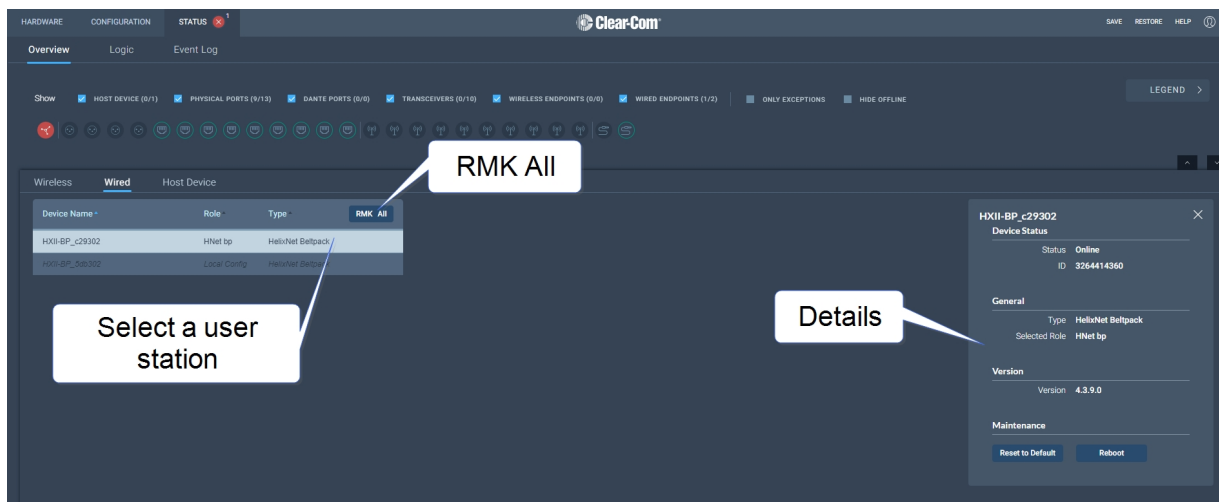

5.24.5 Monitoring the Host Device

Navigate to **Status > Overview > Host Device**. A screen appears that gives information about the Arcadia Central Station and enables various procedures including:

- Reboot
- Reset to Default
- Collect Support Info
- Sync Clock
- Network
 - Management
 - AES67
 - Dante
- General
 - Status
 - Uptime
 - Sync Source
 - Version
- PTP
- Power to the Arcadia Central Station
- Thermal

The screenshot displays the 'Host Device' configuration page for device ID f080925. The interface includes a top navigation bar with 'HARDWARE', 'CONFIGURATION', and 'STATUS' tabs. Below the navigation, there are filter options for various device components and a 'LEGEND' button. The main content area is divided into several sections:

- Network (Management):** IP Address: 10.50.16.25, Subnet Mask: 255.255.252.0, Gateway: 10.50.16.1, Host name: CC-ARC-00015807-0, Primary DNS: 10.50.1.51, Secondary DNS: 10.50.1.151, Port: LAN1, Link Status: Up, MAC: 00:0e:98:08:09:25.
- General:** Status: Good, Uptime: 5 hours 11 minutes, Sync source: PTP.
- Dante:** Dante is not available, neither Dante Primary nor Secondary has been assigned to one of the external LAN ports.
- Version:** Version: 2.3.83.29-38562 (Boot: NEP-1.1.8), Hardware Version: 5.00 (FPGA: 2.3.83.29-38562) (MIXER FPGA: 0x0103) (NRF: Good), HelixNet Version: 4.3.9.0.
- PTP:** Status: LOCKED, Role: Follower, Reference ID: 00-0e-98-ff-fe-08-00-2e (Priority 127), Local ID: 00-0e-98-ff-fe-08-09-29 (Priority 127), Offset from Reference: 224 ns (max 445 ns), Minus Data Delay: 11.678 ms ± 6.45 ns.

5.24.6 Monitoring the Event Log

The Event Log provides useful information about events that happen in the system.

The Event Log can be filtered on:

- Time: default is 1 month prior to the current date and time
- Exceptions (warnings and errors): default is unchecked.

Events are sorted by data. Clicking the small blue arrow changes date order:

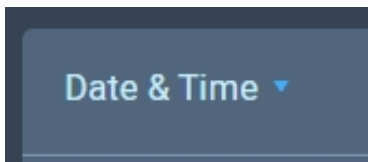

The **Level** column shows the status of data:

- Yellow triangle: warning
- Red circle with white cross: error
- No icon shown: this data is informational.

The following apply to the Event Log:

- The Event Log periodically refreshes but there is a **Refresh** button to pull the latest events
- The Event Log can be exported to a .csv file
- **Clear Event Log** clears current data. The data cannot be retrieved once it has been cleared
- Event logs are not stored permanently, only events since the last power or reboot cycle are available.

5.24.7 Monitoring the Logic Page (Status)



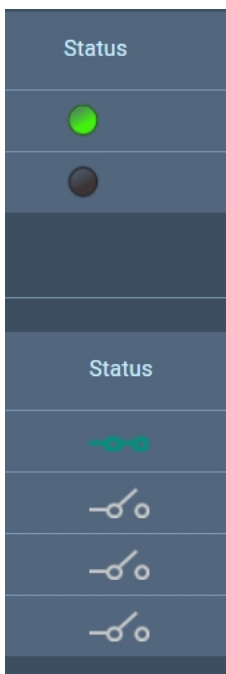

This page shows the GPIs and GPOs (relay) that you have set up in the **Configuration > Logic** page. You can see if these are currently active in the system under the **Status** column.



A green icon indicates a currently active input or relay.

Forcing ON/OFF

The buttons under the FORCE column are toggle buttons that can be used to test the working of the GPIOs or to turn them permanently off or on. These override the working of the configured GPIOs.

Logic Inputs					
	GPI Label	Route Source	Route Destination	Status	Force
1	GPI1	No events assigned	No events assigned		<input type="button" value="OFF"/> <input type="button" value="ON"/>
2	GPI2	No events assigned	No events assigned		<input type="button" value="OFF"/> <input type="button" value="ON"/>
Logic Outputs					
	GPO Label	Key Target	On Behavior	Status	Force
1	GPO1	No triggers assigned	No triggers assigned		<input type="button" value="OFF"/> <input type="button" value="ON"/>
2	GPO2	No triggers assigned	No triggers assigned		<input type="button" value="OFF"/> <input type="button" value="ON"/>
3	GPO3	No triggers assigned	No triggers assigned		<input type="button" value="OFF"/> <input type="button" value="ON"/>

In this example, GPI 1 and GPO 2 are forced ON for testing purposes. GPO 2 is permanently OFF (for example, if you want to ensure that a signal light never comes on at this time).

6 Using FreeSpeak Wireless Intercom

This chapter describes how to connect to E1 and IP transceivers. It contains the following sections:

6.1 Overview of Transceivers	96
6.2 Connecting Transceivers Over E1	96
6.3 Adding IP Transceivers (FS Edge, FS II 1.9)	100
6.4 Connecting Transceivers Over IP	101
6.5 Network Setup for IP Transceivers	102
6.6 Registering Beltpacks (FreeSpeak)	106

6.1 Overview of Transceivers



6.2 Connecting Transceivers Over E1

E1 is a telecommunications standard whereby data and power are sent over Cat 5/6 or Fiber cable (data only). E1 connections must have dedicated cabling as it is not possible to use network switches with this technology.

FreeSpeak II systems (1.9 and 2.4 GHz) can be connected to the Arcadia Central Station using E1 connectivity.

Note: *You must **not** place E1 1.9 GHz and IP 1.9 GHz transceivers in the same RF zone.*

Transceivers can be connected directly to the Arcadia Central Station (up to two transceivers) or connected using FreeSpeak II splitters (up to 2 splitters, each hosting up to 5 transceivers so up to 10 transceivers in total).

Transceivers/splitters are connected to the Arcadia Central Station using connectors G and H. See [Rear Panel Connectors and Indicators on page 27](#).

Note: *Transceivers and splitters can be connected using Fiber or copper cable. If you use Fiber, the devices **MUST** have local power and you **MUST** configure the ports to fiber in the CCM (default = RJ45). Navigate to: **CCM > Host > Wireless > Wireless Transceivers**.*

Example connection with a splitter



Note: The splitter connections are switched between RJ45 and Fiber routing using DIP switches inside the splitter.

For more examples of connection options and how to set the DIP switches, see the FreeSpeak II Splitter Quick Start Guide available from the [FreeSpeak II Knowledge Center](#).

6.2.1 Cable Distances - E1 Connections

Arcadia Central Station to TCVR/splitter	
TCVR directly connected to and powered by the Arcadia Central Station	<ul style="list-style-type: none"> • 328 ft (100 m) using shielded 24 AWG Cat 5/6e cable • 164 ft (50 m) using shielded 26 AWG Cat 5/6e cable
TCVR directly connected to the Arcadia Central Station with local/direct power at TCVR	<ul style="list-style-type: none"> • 2625 ft (800 m) using shielded 24 AWG Cat 5/6e cable • 1312 ft (400 m) using shielded 26 AWG Cat 5/6e cable
Arcadia Central Station to splitter (splitter is powered)	<ul style="list-style-type: none"> • 2625 ft (800 m) using shielded 24 AWG Cat 5/6e cable • 1312 ft (400 m) using shielded 26 AWG Cat 5/6e cable

Splitter to TCVRs	
TCVRs powered by splitter	<ul style="list-style-type: none"> • 328 ft (100 m) using shielded 24 AWG Cat 5/6e cable • 164 ft (50 m) using shielded 26 AWG Cat 5/6e cable
TCVRs have local/direct power	<ul style="list-style-type: none"> • 2625 ft (800 m) using shielded 24 AWG Cat 5/6e cable • 1312 ft (400 m) using shielded 26 AWG Cat 5/6e cable

Note: *Fiber connections: Connection distances will depend on existing cable infrastructure.*

6.2.2 Using a Transceiver With a Fiber Connection

To connect a Arcadia Central Station to a splitter (FSII-SPL) using Fiber, you must install Fiber modules to the Arcadia Central Station and the splitter.

- Modules are available for single mode Fiber cable (HLI-SMFO) and multi-mode Fiber cable (HLI-MMFO).
- Modules must be ordered from Clear-Com as a pair, one for the Arcadia Central Station and one for the splitter.
- Modules can be hot patched. There is no need to power off devices.
- To install the modules, simply remove the dust cap from the connector port and slide the module into the connector.

Note: *When using a Fiber connection, all devices must have local power supplied.*

6.2.3 E1 Transceiver/Splitter Port Connection Type (RJ45 or Fiber)

Transceivers/splitters can be connected to the Arcadia Central Station using either RJ45 cable or fiber cable.

The connection type for the ports is determined by a software setting in the Core Configuration Manager (CCM). Default setting is **RJ45**.

The CCM determines the connection type for both connectors; you must chose either RJ45 or Fiber. It is not possible to mix these connection types on the Arcadia Central Station.

Setting FSII Transceiver/Splitter Connection Type

1. In the CCM, navigate to **Hardware > Hosts > Wireless**.
2. Select **FreeSpeak II > Transceiver Port** type as required.

ff08002c [Close]

Network Upgrade **Wireless** Security

General

Administration PIN

OTA System ID

BP Role List Sorting **Role Number** [Dropdown]

Freespeak Edge

Edge Wireless Region **United States (US)** [Dropdown]

Excluded Channel(s) **Unassigned**

Freespeak II

Transceiver Ports **RJ45** [Dropdown]

AA Battery Type **Alkaline** [Dropdown]

OTA PIN

Set transceiver port connection type

6.2.4 Setting Cable Length Offset (E1)

Cable length offset is used to prevent the DECT or radio signals between transceivers getting out of synchronization. If transceivers are not synchronized, beltpack handover will not happen effectively. This is particularly important if you have overlapping transceiver coverage zones (RF cells) or the beltpacks need to move between coverage zones.

Cable length offset or transceiver sync compensation needs to be set when:

- The difference in total cable length between transceivers is $\geq 1640\text{ft} / 500\text{m}$ (this includes both fiber and copper cable runs).

Example

TCVR #1: total cable length = 328ft / 100m

TCVR #2: total cable length = 2788ft / 850m

The difference in cable length between transceivers = 2460ft / 750m. Therefore, in this case you must set transceiver cable length on both transceivers. This allows any latency to be calculated and offset by the system.

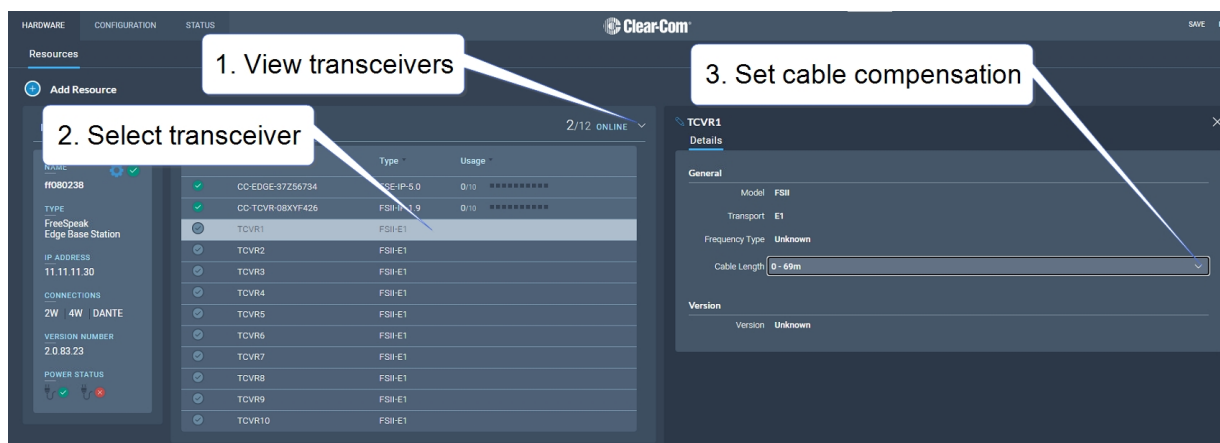

In the configuration tool, navigate to: **Resources > Transceivers > Details > General > Cable Length**

6.3 Adding IP Transceivers (FS Edge, FS II 1.9)

Note: To add E1 transceivers, see [Connecting Transceivers Over E1 on page 96](#).

To add IP transceivers:

1. Navigate to **Hardware > Resources** and select **Add Resource**. The following screen appears.

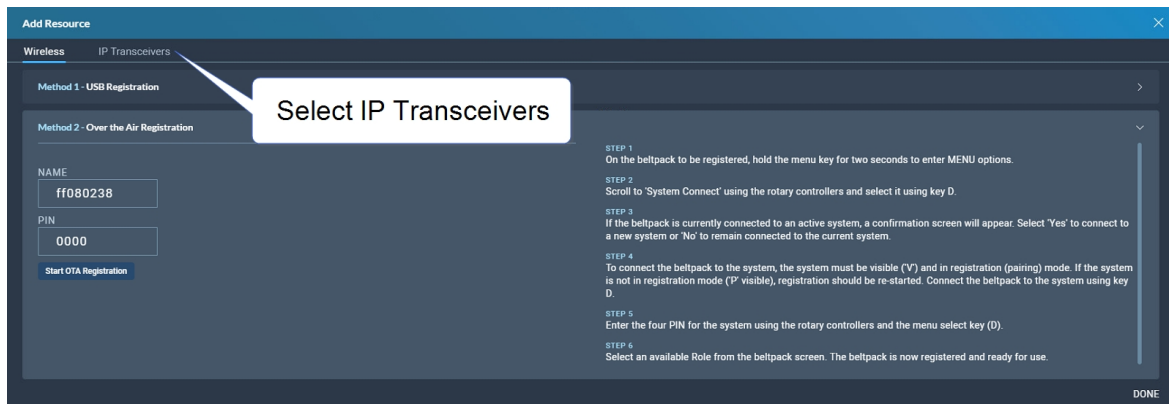

2. Select **IP Transceivers**. The following screen appears:

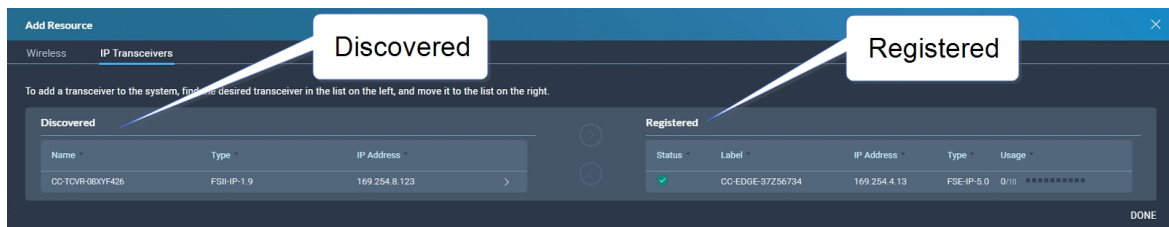

3. Select the transceiver that you want to register from the left-hand area of the screen, and click the right-hand arrow.

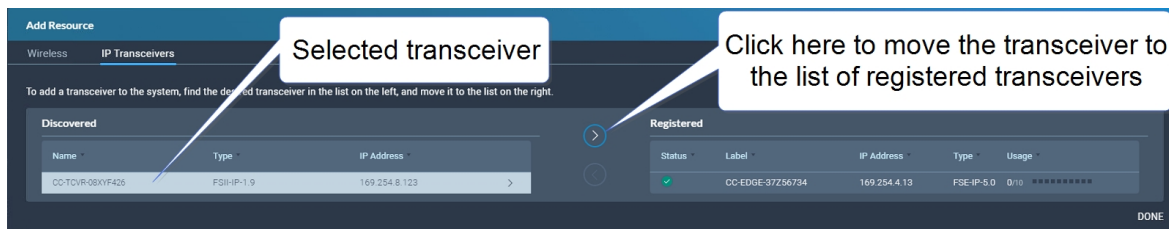

The selected transceiver appears in the right-hand list of registered transceivers.

6.4 Connecting Transceivers Over IP

When connecting IP transceivers, connect them to the LAN connector that is configured for AES67 on the rear of the Arcadia Central Station using Ethernet cable.

See [Network Setup for IP Transceivers on page 102](#).

Once your transceivers are set up on the network you will add them to your system using the CCM.

See [Adding IP Transceivers \(FS Edge, FS II 1.9\) on page 100](#).

6.5 Network Setup for IP Transceivers

The Arcadia® Central Station has four IP addresses. IP traffic is spread over these addresses. See LAN ports 1 - 4 (I and J). See [Rear Panel Connectors and Indicators on page 27](#).

The LAN ports are fully user configurable but you can work with the following default settings:

- LAN 1: Management and AES67 (AoIP) audio traffic are combined on this connector
- LAN 2: Not configured
- LAN 3: Not configured (SFP)
- LAN 4: Not configured (SFP)

6.5.1 Connection to IP Transceivers, Example 1

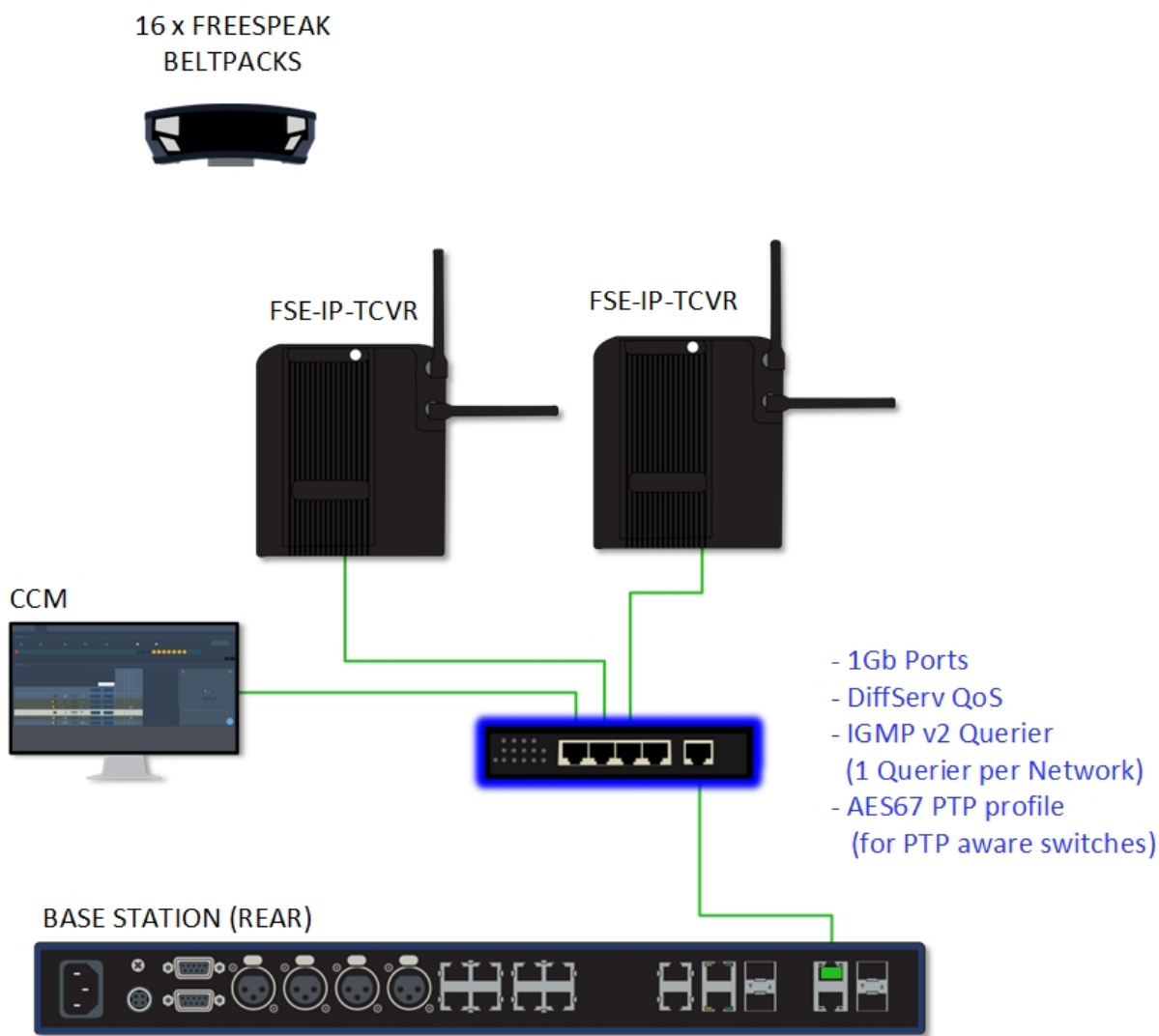

6.5.2 Connection to IP Transceivers and Dante, Example 2

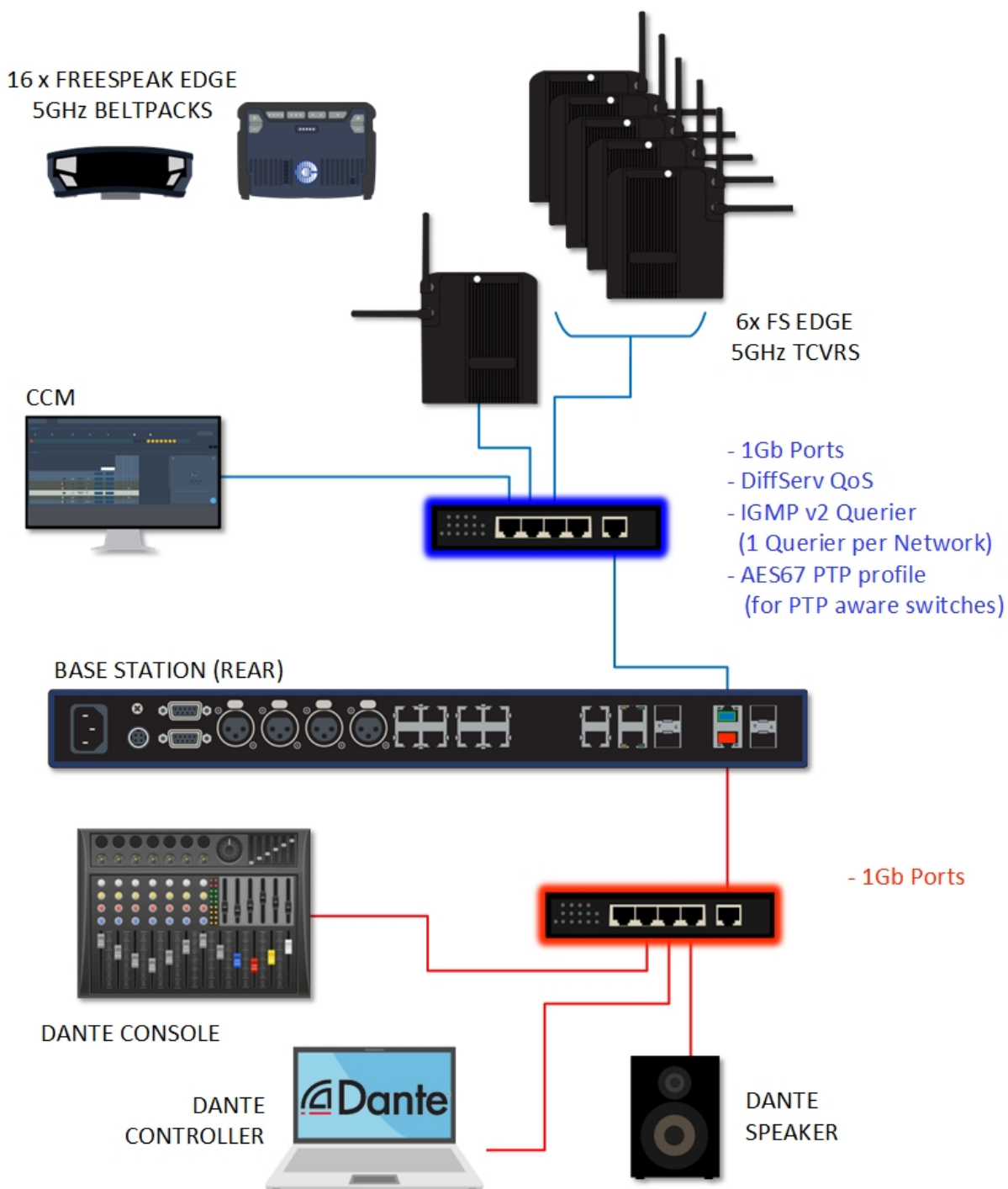

6.5.3 Connection to IP Transceivers and Dante, Example 3

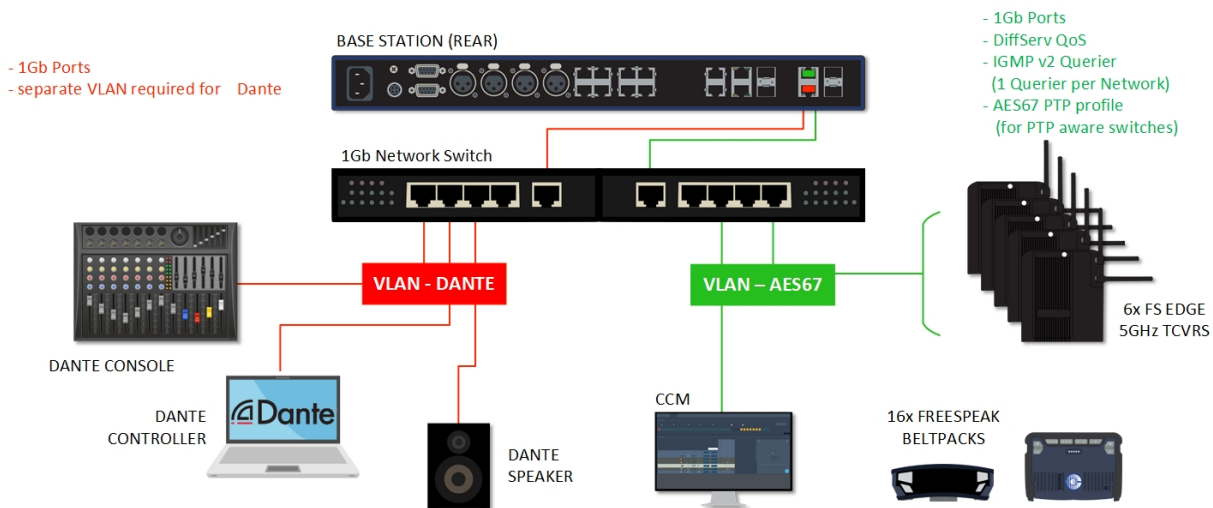

6.5.4 Connection to IP Transceivers, Example 4

If you are connecting to a network set up where there is lots of traffic, either management or AES67, Clear-Com recommends that you split AES67 traffic into its own segment.

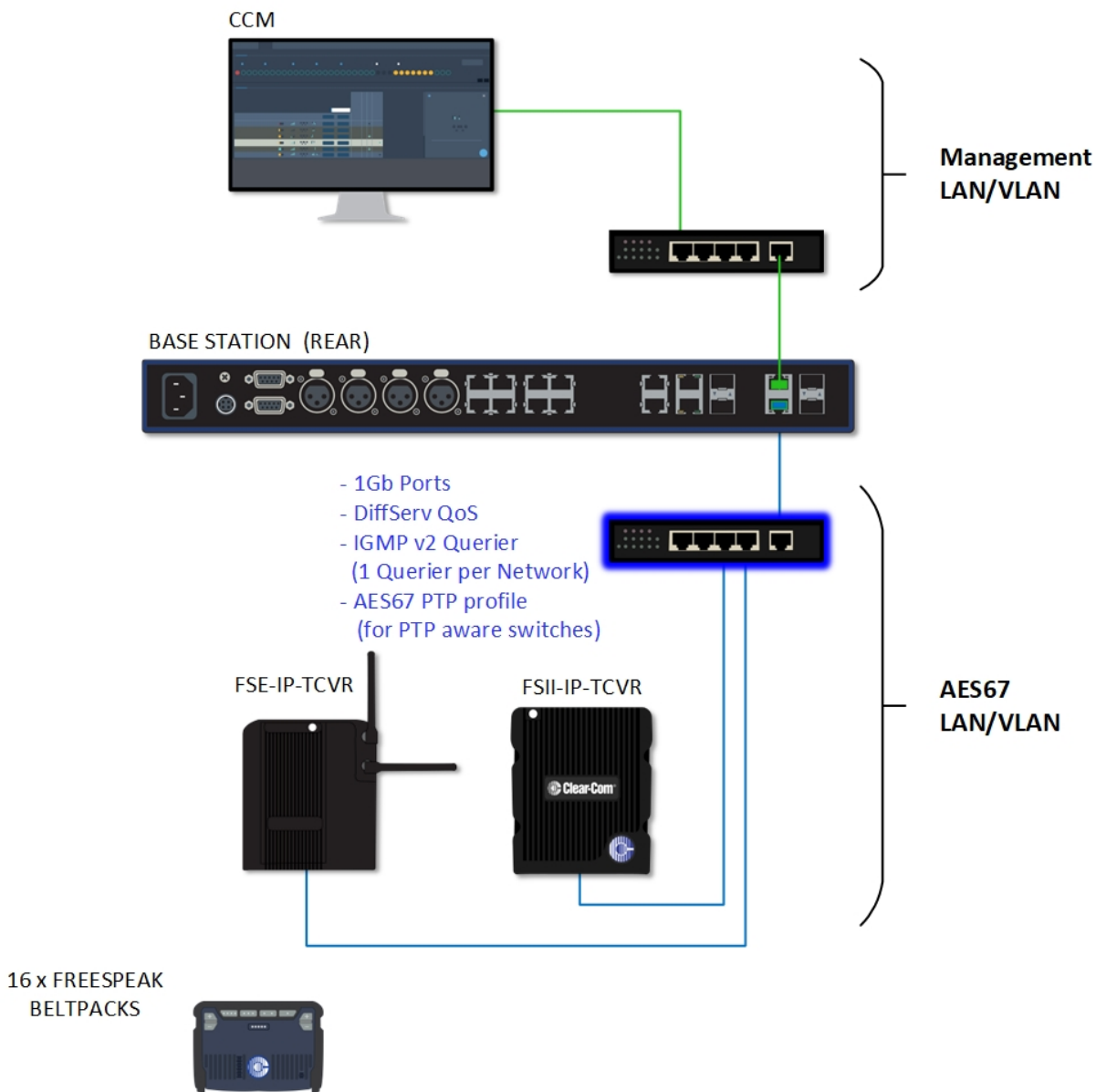

6.5.5 Setup Rules

- The default setup (management and AES67 audio on the same connector) is intended for use with a dedicated network switch for the Arcadia Central Station and its transceivers (see example network setup, example 1).
- If you do not have a network switch that is dedicated to the Station and transceivers, Clear-Com recommends that you split AES67 traffic onto a separate LAN (see example network setup, example 4). This is in order to accommodate the IP transceivers' need for high clocking accuracy. Too much traffic on your network will degrade the performance of your IP transceivers.
- For the AoIP network, try to keep the number of layer 2 hops between PTP leader and follower as low as possible (no more than 3). If more are required, consider using a Boundary Clock or a Transparent Clock.
- For more information on achieving a well-regulated PTP network and recommendations for suitable switches, see *Clear-Com AoIP Network Recommendations* available from the [FreeSpeak II Knowledge Center](#).
- Use DHCP (the default setting) for fast and easy setup of the devices. If the device does not encounter a DHCP server on the network it will automatically allocate an address in the link-local range (169.254.xx.xx).
- IP addresses can be configured statically under **Hardware > Resources > Network** in the CCM.
- For information on the 5 GHz transceiver (status and connection indicators) see the *Edge Transceiver Quick Start Guide* available from the [FreeSpeak Edge Knowledge Center](#).
- Connection status indicators on the FreeSpeak II IP transceiver are the same as the Edge transceiver (no channel scan).
- For PoE to the transceivers you will need a PoE enabled network switch.

6.6 Registering Beltpacks (FreeSpeak)

Before you can use a beltpack, you must register it. This enables the Arcadia® Central Station to associate the beltpack with roles and assigned keys.

You can register a beltpack in two ways:

- By USB cable. When registering a beltpack in this way, a role that assigns keys to the beltpack is automatically created and fixed to the beltpack. The role can be edited as required in the **Configuration > Roles** page of the CCM.

- Over The Air (OTA). When you register a beltpack in this way you must create a role for it manually in **Configuration > Roles** before the beltpack can connect.

6.6.1 Registering a beltpack by USB cable

This method of registering beltpacks is recommended for fast and easy set up.

To register a beltpack using a USB cable, connect a beltpack to Arcadia Central Station using a USB A to micro USB B (FSII) / USB C (FSE) cable. The beltpack can be powered on either before or after connection. The Arcadia Central Station will show 'Beltpack [ID] is now registered' in the front menu screens.

Note: *When beltpacks are registered in this way, a role with two channels (1 and 2) is automatically generated and applied to the beltpack. Roles can be edited at any time in the **Configuration** page of the CCM.*

6.6.2 Registering a beltpack OTA

To register a beltpack using OTA:

1. Navigate to **Hardware > Resources** and click **Add Resource**. The following screen appears:



2. Click **Start OTA Registration**.

Note: *A timer is started indicating how long the system is open for registration. You can close OTA registration on the system at any point.*

6.6.3 Unregistering a beltpack

To unregister a beltpack, navigate to **Hardware > Resources > Endpoints** (click the down arrow to see all connected Endpoints (beltpacks)). Select an Endpoint by clicking on it. Select

Unregister.

 **EDGE-BP-524403** ✕

General

Model **FSE**

Frequency Type **5.0 GHz**

ID **524403**

Fixed Role **Producer** 

Version

Version **4.6.79.0**

Unregister

Free up any assigned resources and deauthorize endpoint from future connections to this system.

Unregister

7 Using HelixNet Wired Partyline Intercom

This chapter describes how to connect to HelixNet Wired Partyline Intercom. It contains the following sections:

7.1 Introduction	110
7.2 HelixNet Connections - General Outline	111
7.3 Connecting HelixNet user stations to the network	112
7.4 Pairing HelixNet user stations to the Base Station	113

7.1 Introduction

Arcadia supports HelixNet wired partyline intercom, including the HRM-4X remote station, the HKB-2X speaker station and the HXII-BP beltpack. To do this, Arcadia channels must be enabled for HelixNet. HelixNet user stations connect to Arcadia via an ethernet network and HelixNet keysets can be assigned to any HelixNet enabled channel in the Arcadia system. Each HelixNet enabled channel requires an Arcadia licensed port.

HelixNet wired beltpacks, remote stations and speaker stations are connected to the Arcadia Central Station on the LAN port that is configured for the HelixNet network (default LAN 1) via an Ethernet network.

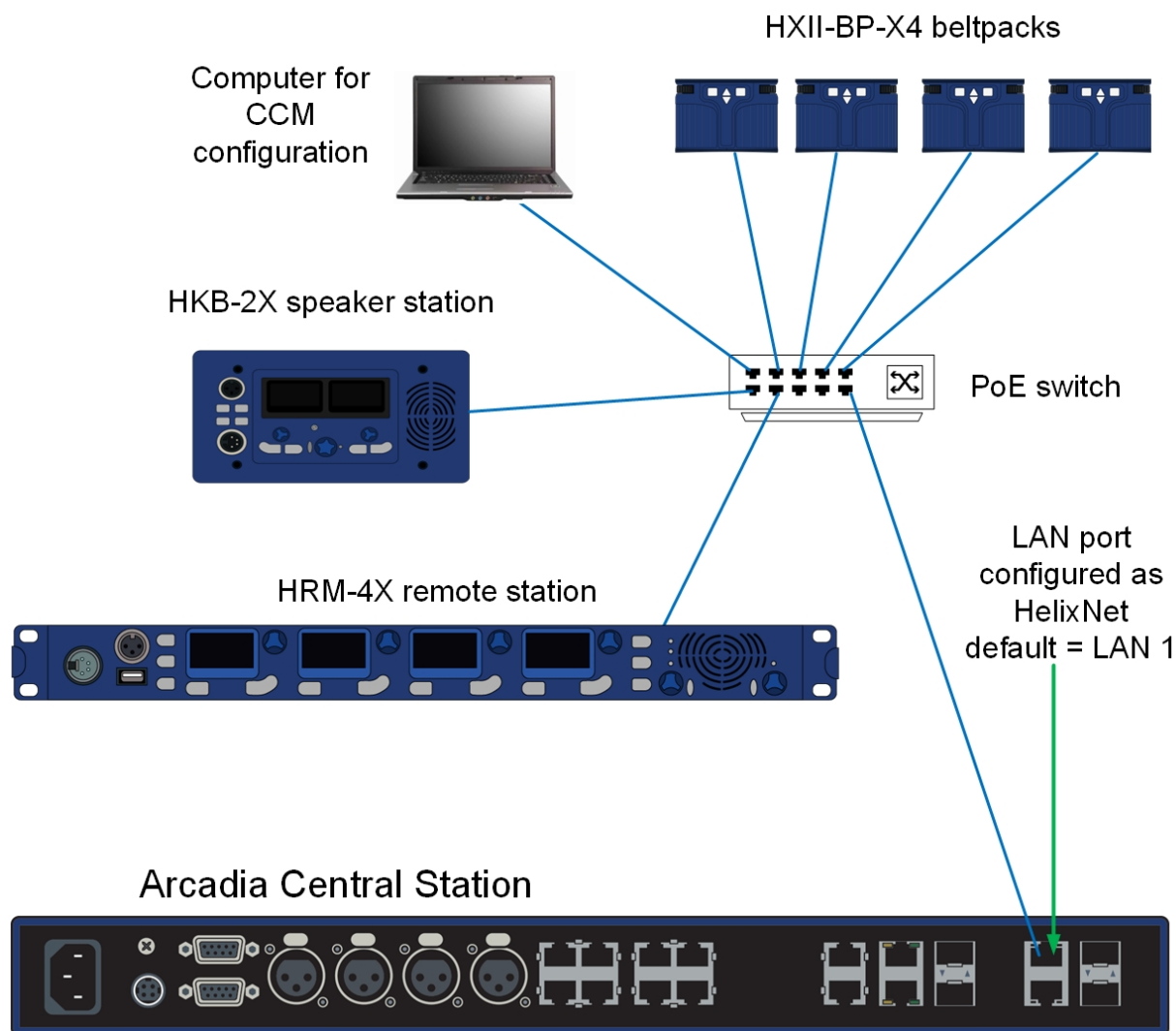

Note: Arcadia's HelixNet network is combined with the Management network and cannot be separated at the time of writing.

Note: When using an IEEE-802.3af compliant PoE switch, be sure to note the switch's power budget. Each HXII-BP-X4 requires 4 Watts of power. The HRM-4X and the HKB-2X each require 15.4

Watts of power from the switch. Do not exceed the power budget of the switch when attaching devices.

Note: You can enable up to 24 channels for HelixNet. How many channels you use is limited by how many port licenses you have. One HelixNet enabled channel consumes one port license.

Note: HelixNet connectivity in Arcadia is channel based only. There are no direct/point-to-point connections available for assignment to HelixNet keysets.

Note: HelixNet should be listed in the CCM under **Hardware>Host**. If it is not listed and your device is manufactured before June 1st 2022 it may require a HelixNet activation license. Please contact Clear-Com Sales for further information.

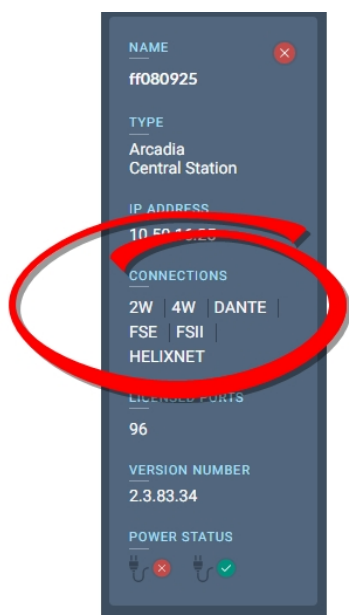

See the *HelixNet for Arcadia User Guide* for more information on the HelixNet system and components.

7.2 HelixNet Connections - General Outline

Before connecting HelixNet beltpacks you must have:

- At least 1 channel enabled for HelixNet (by default, channels 1 - 4 are enabled). See [Enabling Channels for HelixNet on page 66](#)
- Sufficient number of licensed ports for the HelixNet enabled channels (max 24)
- **Port Type** on at least 1 licensed port set to type **Any** (default) or **HelixNet**. If this is not done, HelixNet keysets cannot be assigned

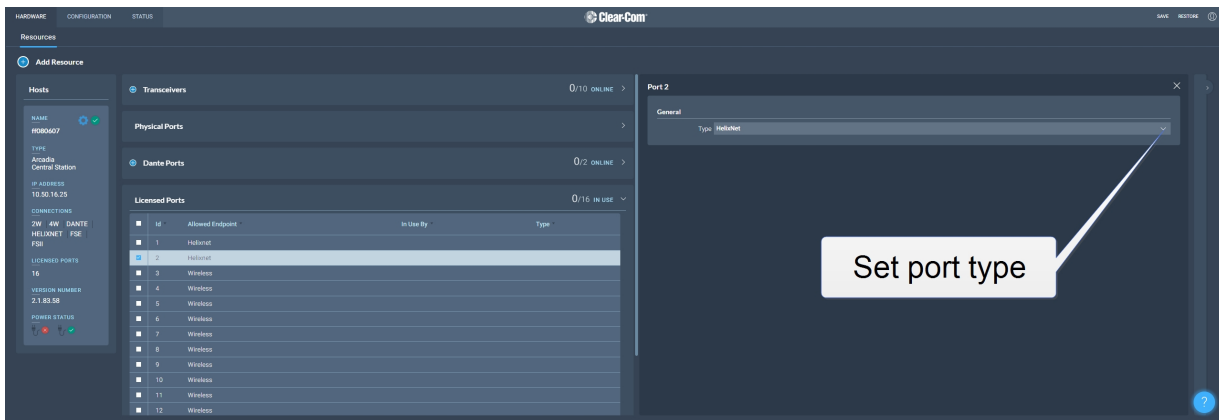

For a quick test setup, you can work with the default settings which allow licensed ports to be used for any function and have 4 channels HelixNet enabled. For a full installation, you can enable channels and create roles for HelixNet beltpacks, remote stations and speaker stations.

7.3 Connecting HelixNet user stations to the network

HelixNet wired devices are connected to Arcadia's HelixNet network using the RJ45 ethernet connector on the back of each device.

HXII-BP-X4 beltpack base connectors



Connect RJ45 Ethernet cable here

HRM-4X remote station rear connectors



Connect power supply unit (PSU) here

Connect RJ45 Ethernet cable here

S-Mount (rear connectors) housing an HKB-2X speaker station



Connect RJ45 Ethernet cable here

Connect power supply unit (PSU) here

Note: *Troubleshooting: you may need to make sure that the connecting device is in the same IP range as the host system. To view and edit the device IP address, navigate to **Networking>Preferences>IP address** in the device menu system.*

7.4 Pairing HelixNet user stations to the Base Station

Once connected to Arcadia's HelixNet network and appropriately powered, HelixNet beltpacks, remote stations and speaker stations can be paired to the Arcadia system:

- from the CCM
- from the HelixNet user station, using the front panel menu

Note: *Pairing from the CCM is not available for endpoints that were last used on a HelixNet HMS-4X based system. Endpoints migrating from HMS-4X to an Arcadia system must initially be paired from the front panel menu of the HelixNet user station.*

Pairing/unpairing HelixNet user stations in the CCM

When the user stations are connected to the Arcadia HelixNet network and appropriately powered, they will appear as **Discovered** in the CCM.

1. In the CCM, navigate to **Hardware>Resources>Add Resource**  **>Wired** .
2. Select the device under **Discovered** and click the arrow to move it to **Paired**.
3. The device will work through its connection sequence.
4. The device is ready for use.

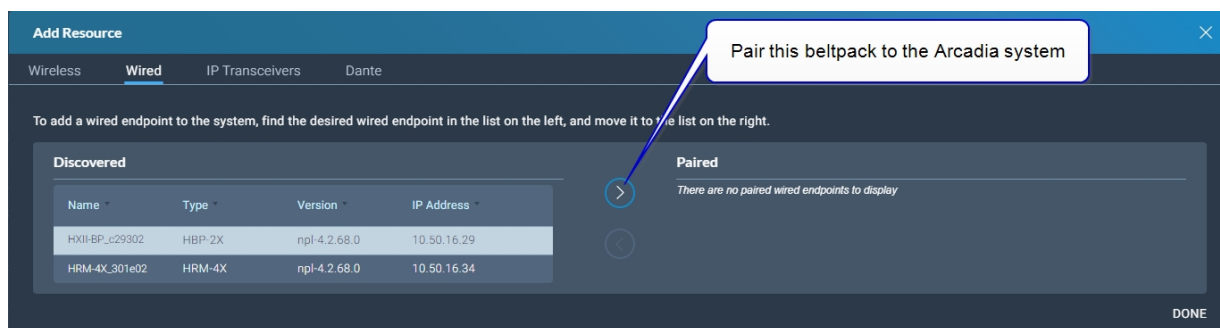

Repeat this step for each device.

Note: *The device will automatically update on connection if a difference in firmware versions is detected.*

Once paired to a system, the device will automatically connect to that system whenever it is connected to the network. The devices can be unpaired from the system to prevent this from

happening. To unpair a device from the system, navigate to **Hardware>Resources>Endpoints** [select device]>**Unpair**.

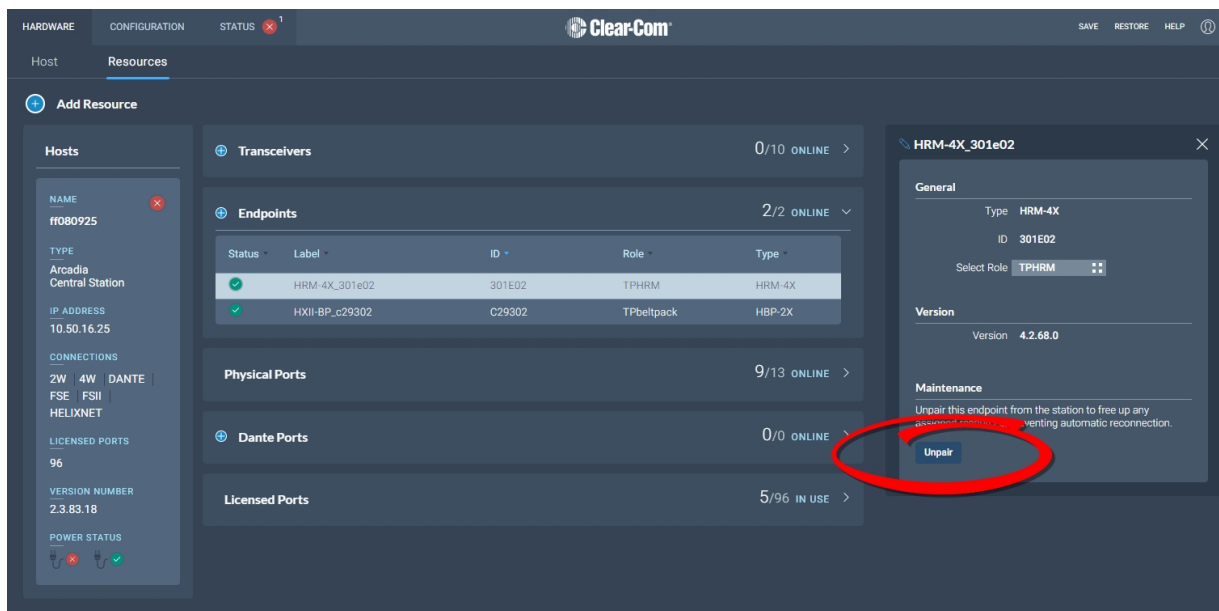

Pairing HelixNet endpoints from the device menu system

Beltpacks

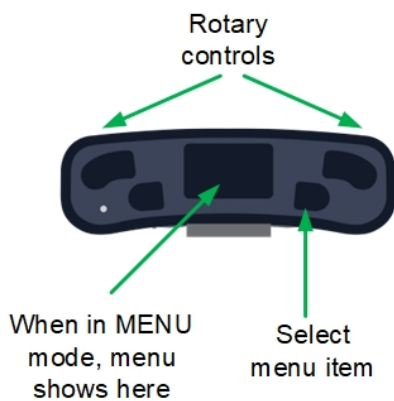

1. Press the **Menu** button on the front of the beltpack (short press) to enter menu mode.
2. Press the left call button on the beltpack (**back**). You will see the beltpack menu system.
3. Using the rotary controls and the right call button (**select/enter**), navigate to **Networking>Pair to Station**.
4. Select either;
 - **Pair by Name** and select the name of Arcadia
 - **Pair by IP** and enter the IP address of Arcadia's HelixNet network connector

Note: You need to **Save** the IP address (right call button).

Remote stations and speaker stations

1. Press the **Menu** button to enter menu mode.
2. Using the rotary controls, navigate to **Networking>Pair to Station**.
3. Select either;
 - **Pair by Name** and select the name of Arcadia
 - **Pair by IP** and enter the IP address of Arcadia's HelixNet Network using the rotary controllers

Note: All devices will automatically update on connection if a difference in firmware versions is detected.

Using HelixNet user stations on Arcadia

Once the HelixNet user station is connected to the Arcadia and the firmware updated if necessary, the HelixNet user station can be configured.

Arcadia's default configuration assigns the first channels of the system to the HelixNet user stations on connection.

HelixNet user stations can be operated in **Local Config**. In this case, the user station is fully configured from its front panel menu. Any of the connected Arcadia's HelixNet enabled channels can be assigned to the keysets of the user station.

Where central management is required, **Roles** can be created in the Arcadia's CCM and then assigned to the HelixNet user station, either from the CCM's **Hardware>[Endpoint]>Properties** or in the front panel menu of the user station. A role is a configuration of the keysets and settings of the user station. Multiple HelixNet devices can share a role and any role changes will be updated in real time.

- Create roles for your devices. See [Managing Roles on page 74](#)

For HelixNet manuals and other resources see:

[The HelixNet Knowledge Center](#) on the Clear-Com website.

8 Using Dante Systems

To configure Dante you must be familiar with the Audinate Dante Controller, available from the Audinate website.

Before configuring the connection in the Dante Controller, you must determine which of the 4 RJ45 LAN connectors on the Arcadia Central Station you wish to use for Dante network traffic.

See [Rear Panel Connectors and Indicators on page 27](#).

Note: *The PC running the Audinate Dante Controller must also be connected to the Dante network.*

Note: *The Dante connection on the Station supports both Dante and Dante (AES67).*

Determining which LAN connector you wish to use for Dante must be done in the CCM.

Navigate to **Hardware > Host**. Under the **Network** tab, select the port for Dante. This port will default to a DHCP setting. If you wish to configure a static IP address you must do this in the Dante controller.

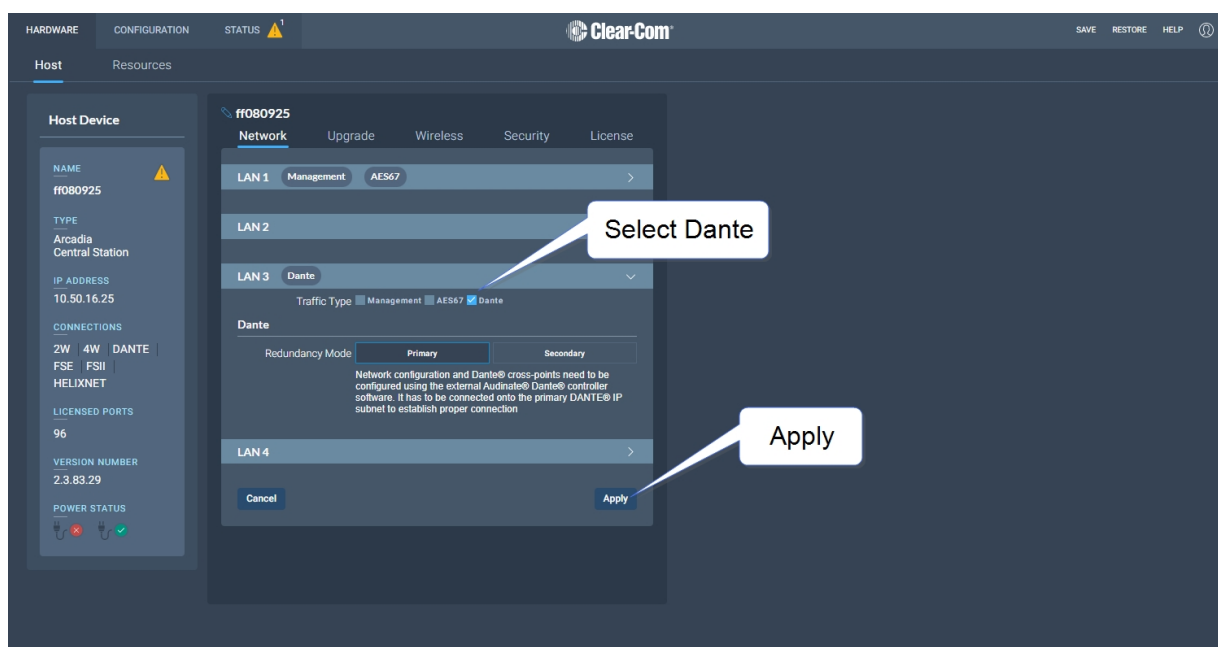

Note: *LAN 3 and 4 are for use with an SFP module (either fiber or RJ45).*

Note: *You must have sufficient licensed ports; each Dante channel consumes one licensed port. See [Licensed Ports](#) under [Configuring System Resources on page 49](#).*

LAN connectors can be configured in any way you wish, but the CCM enforces that you MUST NOT configure IP transceivers (AES67) and Dante traffic on the same network. This is because AES67 network traffic has higher timing requirements than Dante network traffic, due to the need for IP transceivers to achieve DECT synchronization.

When configuring Dante connections, the Dante subsystem IP configuration is determined by the Dante Controller.

1. In the CCM, navigate to **Hardware > Host > Network** and configure Dante on the LAN connector you wish to use for Dante connections.
2. Connect a cable (Cat5/6e or fiber) to the LAN connector that is designated for Dante. Connect the other end to a switch on your Dante network.
3. Open the Dante Controller and check that the network interface details are correct.

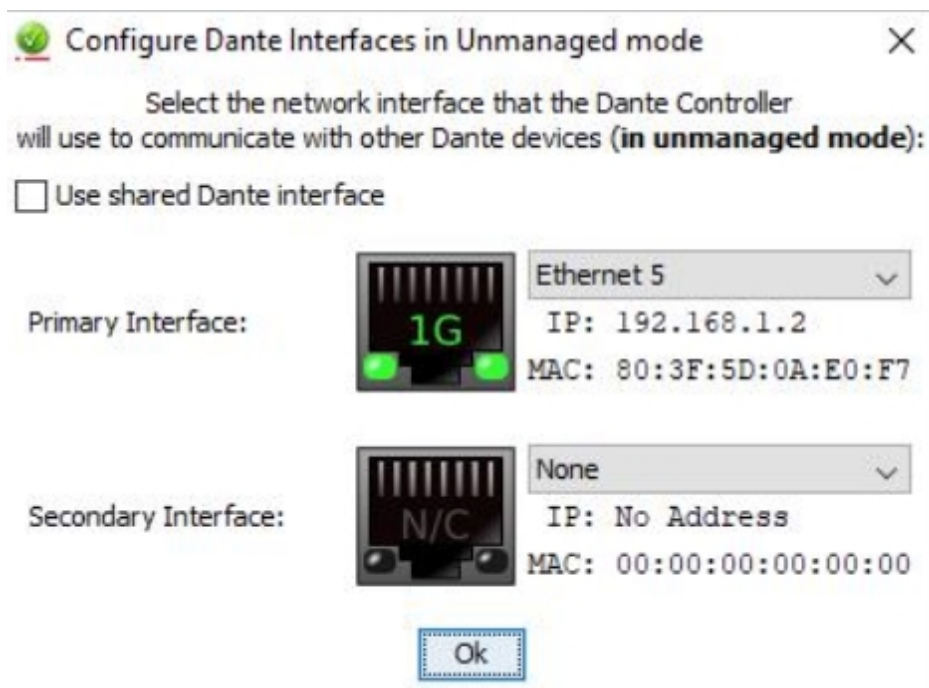

4. Check network and connection details under the **Status** tab in the CCM.



5. Details can also be viewed in the Dante Controller.

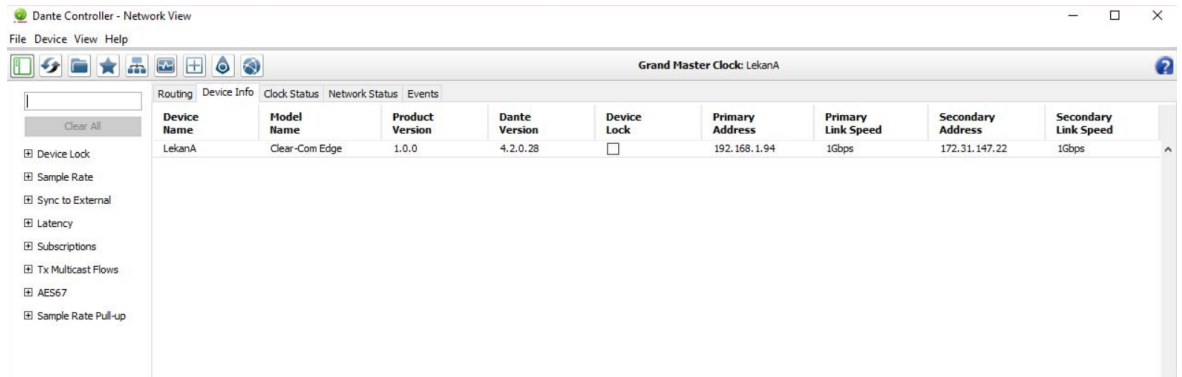

6. In the CCM navigate to **Hardware>Resources>Dante Ports** and add Dante ports. Give the new ports a suitable label.

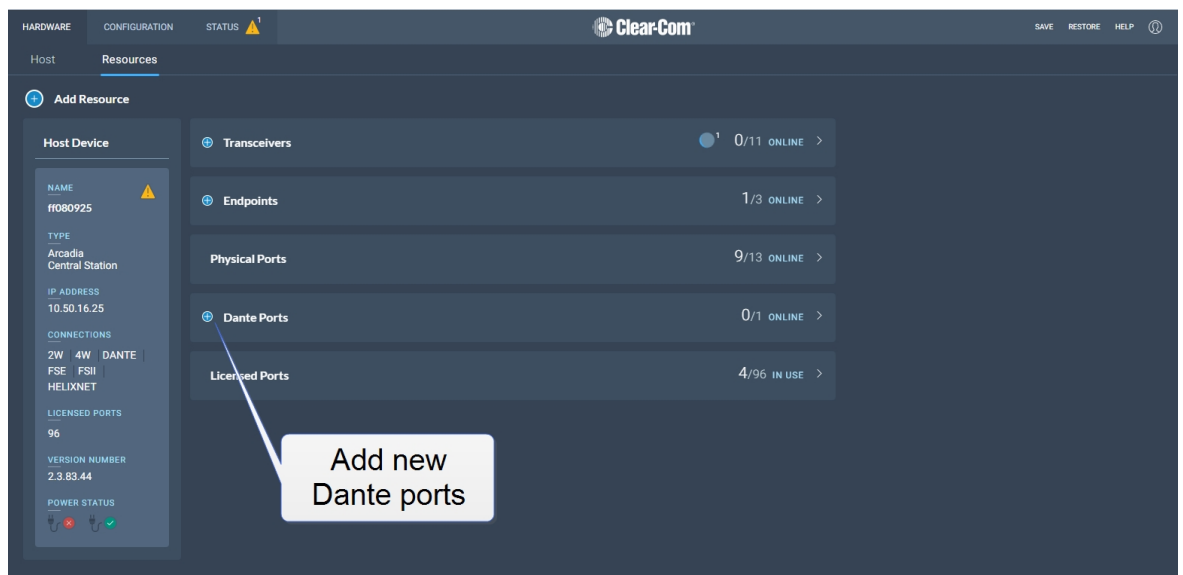

7. Route the channels as required in the Dante Controller.
8. You will see available Dante ports in the **Configuration** page of the CCM. These ports can be assigned to channels on the Arcadia Central Station in the usual way.
9. Select the required channel click the + icon next to the port.

The screenshot displays the Clear-Com Arcadia Central Station interface. At the top, there are tabs for SYSTEM, SETUP, and STATUS. The main navigation bar includes Channels, Groups, Roles, and Logic. The 'Channels' tab is active, showing a table of channels and a 'Ports' section on the right. A callout box with the text 'Click here' points to the 'Dante P 1' port in the 'Dante' section of the 'Ports' list.

Channels 2/100 USED

Status	Id	Name	Online	Talkers
✓	1	Channel 1	2/2	1
✓	2	Channel 2	1/1	0

Channel 1

- Dante P 1
- Edge Base

Ports 1/20 ASSIGNED

	2W-Port A	2W-Port A	None
✓	2W-Port B	2W-Port B	None
✓	2W-Port C	2W-Port C	None
✓	2W-Port D	2W-Port D	None
4W			
✓	4W-Port1	4W-Port 1	None
✓	4W-Port2	4W-Port 2	None
✓	4W-Port3	4W-Port 3	None
✓	4W-Port4	4W-Port 4	None
✓	4W-Port5	4W-Port 5	None
✓	4W-Port6	4W-Port 6	None
✓	4W-Port7	4W-Port 7	None
✓	4W-Port8	4W-Port 8	None
Dante			
✓	Dante P 1	Dante-Port 1	Channel 1
✓	Dante P 2	Dante-Port 2	None
✓	Dante P 3	Dante-Port 3	None
✓	Dante P 4	Dante-Port 4	None
✓	Dante P 5	Dante-Port 5	None
✓	Dante P 6	Dante-Port 6	None
✓	Dante P 7	Dante-Port 7	None
✓	Dante P 8	Dante-Port 8	None

9 Using 2-Wire Systems

This chapter describes how to use the Arcadia Central Station with 2-Wire intercom devices. It contains the following sections:

9.1 Introduction to 2-Wire Systems	121
9.2 Using Stations to Interconnect Equipment	122

9.1 Introduction to 2-Wire Systems



- Power: Enabled/**disabled**
- Mode: **Clear-Com**/RTS
- Termination: Enabled/**disabled**
- Nulling: Start Nulling

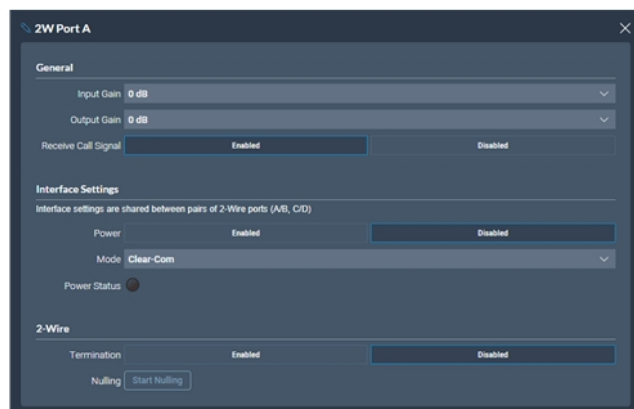

When connecting 2-wire equipment the following applies:

- Every time equipment is changed on a 2-wire interface (port) you should perform nulling. You must null every time you add wired resources to your system.
 - No one should listen during the nulling process.
 - It is good practice to press the remote mic kill (RMK) button on all channels before nulling.
- Encore beltpacks can be powered by the Arcadia Central Station via the partyline. Quantity of beltpacks and length of cable are variables, dependent on the type of devices and existing cabling. To calculate what will work best in your circumstances, see the [Encore Partyline Power Calculator](#), available from the Clear-Com website.
- Enable/disable the partyline power. Default setting: **Disabled**.

These functions can be set either in the 2-wire port settings page of the Core Configuration Manager (CCM) or from the front panel screens on the Arcadia Central Station.

- Enable/disable Line termination. The line should only be terminated once on interconnected devices, do not terminate on more than one piece of equipment. Default setting: **Disabled**.

Line termination is set in the CCM (not the front panel menu system). To do this, in the CCM navigate to: **Hardware > Resources > Physical Ports**. See below.

To configure 2-wire port settings in the CCM navigate to: **Hardware > Resources > Physical Ports > (select port)** :

2W Port A

General

Input Gain **0 dB**

Output Gain **0 dB**

Receive Call Signal **Enabled** Disabled

Interface Settings

Interface settings are shared between pairs of 2-Wire ports (A/B, C/D)

Power **Enabled** Disabled

Mode **Clear-Com**

Power Status

2-Wire

Termination **Enabled** Disabled

Nulling **Start Nulling**

9.2 Using Stations to Interconnect Equipment

When connecting Clear-Com Stations to other Clear-Com equipment and third-party systems (2-wire) use the following guidelines.

Device Type	Supports call signalling?
HelixNet HLI-2W2*	Yes
Encore MS-702/4	Yes
Encore RS Beltpack RS-701 / 702 / 703	Yes
RTS 2-wire equipment	Yes, but does not pass call signalling to 4-wire audio routes.
FreeSpeak/FreeSpeak II Base II*	Yes**
2-way radio	Yes, via a TW-47 interface

*Where there is a choice between a 2-wire and a 4-wire connection, 4-wire provides the best audio quality and is preferred.

** On a FreeSpeak II Base Station only ports 3 and 4 support call signalling.

10 Using 4-Wire Systems

This chapter describes how to use the Arcadia Central Station with 4-Wire intercom devices. It contains the following sections:

10.1 Introduction to 4-Wire Systems	125
10.2 Port Function	126
10.3 Using Stations to Interconnect Equipment	127

10.1 Introduction to 4-Wire Systems

When connecting to 4-wire equipment the following applies:

- To minimize noise and meet regulatory requirements, use screened (shielded) cable when connecting 4-wire ports.
- Pinout configuration (Port Function) can be set on all the Arcadia Central Station 4-wire interfaces. This is a software switch that switches the configuration of the pins on the RJ45 connectors according to the device you are connecting to. Default setting: **4-wire-X**.

10.1.1 Example Connections

Edge Base Station connected to an Eclipse Matrix

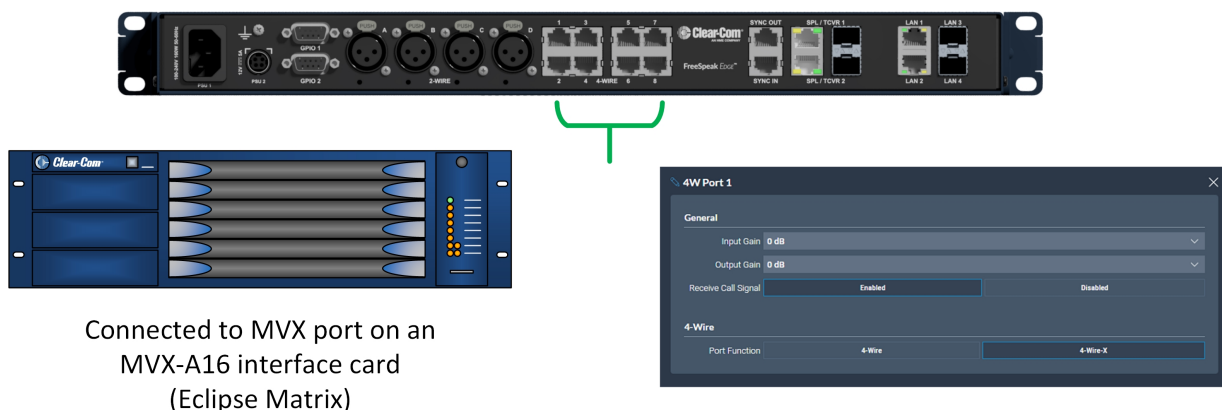

Connected to MVX port on an MVX-A16 interface card (Eclipse Matrix)

- Call signal: **Enabled**
- Port Function type set to : **4-wire-X**

Edge Base Station connected via Cat5 to a HelixNet Base Station

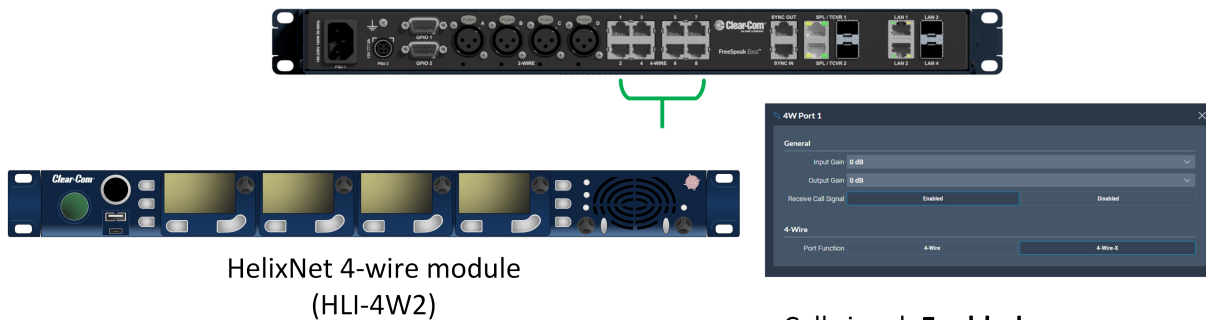

- Call signal: **Enabled**
- Port Function type is set to: **4-wire**

10.2 Port Function

Check this function whenever you are connecting 4-wire devices (not GPIO DB-9M connectors) to your Arcadia Central Station. Default = **4-wire-X**.

10.2.1 About Port Function

Clear-Com products are designed so central audio routing devices (base stations and matrices) can connect directly to other Arcadia Central Stations using a straight-through CAT 5/6 cable. The pin assignments (inputs and outputs) on these devices are complementary. Previously, a crossover cable was necessary when connecting bases to other bases (RJ45 connector). It is no longer necessary to use a crossover cable as there is now a **Port Function** toggle which changes pinouts as required. To set this function navigate in the CCM to **Hardware > Resources > Physical Ports** and select the required 4-wire port.

10.2.2 Port Function Pinouts

Pin No	4-wire	4-wire-X (default)
1	Data in +	Data out +
2	Data in -	Data out -
3	Audio in +	Audio out +
4	Audio out +	Audio in +
5	Audio out -	Audio in -
6	Audio in -	Audio out -
7	Data out +	Data in +

Pin No	4-wire	4-wire-X (default)
8	Data out -	Data in -

10.2.3 Setting Port Function (Pin Polarity) on a 4-Wire Connection

1. Connect the devices using 1:1 Cat5/6/6e cable.
2. In the CCM, navigate to **Hardware > Resources > Physical Ports**.
3. Select the 4-wire port.
4. Select **Port Function**.

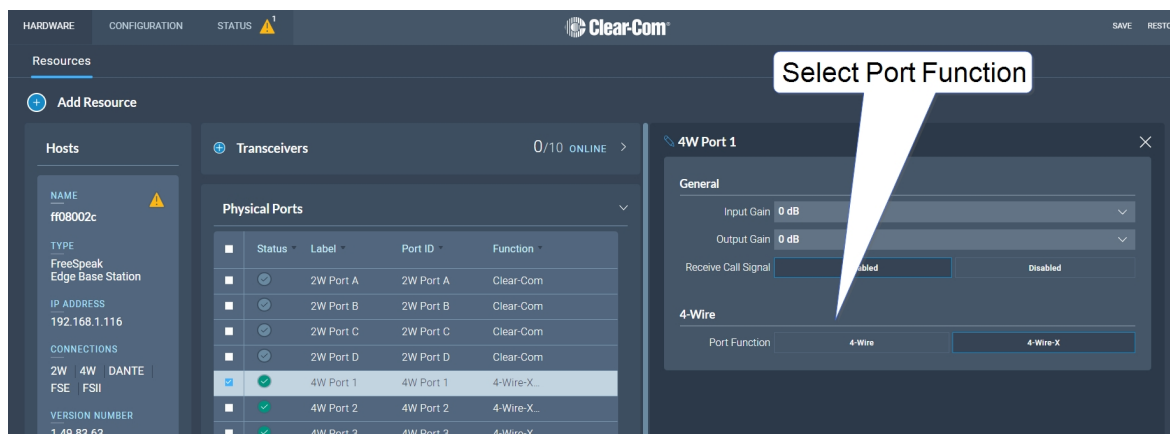

10.3 Using Stations to Interconnect Equipment

When connecting Clear-Com Stations to other Clear-Com equipment and other third-party systems (4-wire) use the following guidelines:

Device Type	Port Function	Supports call signalling?
HelixNet HLI-4W2	4-wire	Yes
Eclipse MVX-A16	4-wire-X	Yes (Identified as a CCI-22 in the software)
Other matrices (third party)	Depends on third-party pinout	No
HME DX200/DX210/DX410	4-wire	Yes
FreeSpeak II Base II	4-wire	Yes
FreeSpeak II	4-wire	Yes **
Arcadia Central Station	When connecting two Stations with a straight cable, the Port Function settings must be as follows: Station 1: 4-wire Station 2: 4-wire-X	Yes
2-way radio : 4-wire device with relay activation *	Depends on third-party pinout	Yes (call signal can fire relay)
LQ Series	4-wire	Yes

* Connect to a DB9 on the Station rear.

** On a FreeSpeak II Base Station only ports 3 and 4 support call signalling.

11 Upgrading Firmware

This chapter describes how to upgrade the firmware on your Station. It contains the following sections:

11.1 Introduction	130
11.2 Upgrading using the CCM	130
11.3 Upgrading using a USB stick	130
11.4 HelixNet Upgrade	131

11.1 Introduction

There are two ways to upgrade the firmware on the Arcadia Central Station:

- Using the CCM web interface. When upgrading from the CCM, you can upgrade all connected resources (for example, transceivers and beltpacks).
- Using a USB stick (USB A on the front of the Arcadia Central Station). When upgrading in this way, only the Arcadia Central Station can be upgraded.

Device to upgrade	File extension
Arcadia Central Station, FS II IP TCVR, FS Edge IP TCVR	.ccf
FS II beltpack, FS II E1 TCVR	.fww
FS Edge beltpack	.ccu
HelixNet	See Upgrading HelixNet below

11.2 Upgrading using the CCM

1. In the CCM, navigate to **Hardware > Host > Upgrade**.
2. Press **Select File** and select the file containing the updated firmware.
3. When the file is uploaded, the **Upgrade** button will be enabled.
4. Press the **Upgrade** button.
5. The upgrade process will start and the Arcadia Central Station will reboot before being available again.
6. The new version of the firmware will be displayed in the **Hosts** panel.

11.3 Upgrading using a USB stick

1. Copy the firmware file onto a USB stick. The file must be at the top level of the USB drive, not within any folders.
2. Insert the USB into the USB port on the front of the Arcadia Central Station.
3. Press the **Menu** button.
4. Using the rotary controllers, navigate to **Administration > Software > Update**.
5. The display will show the available firmware files stored on the USB. Select the one you require.

6. Press the 4th rotary encoder. The unit will upgrade and then reboot.
7. To check the current firmware version, in the menu system navigate to **Administration > Software > Current**. The current software version is displayed in the 4th menu screen.

11.4 HelixNet Upgrade

Upgrades to the HelixNet system are included with the Arcadia software. The HelixNet system requires that all connected devices have the same firmware. Therefore, any mismatches that are detected will cause an immediate and automatic upgrade (or downgrade) to the HelixNet devices on connection. The HelixNet system will also upgrade automatically when the Arcadia Central Station is upgraded.

12 Licensing

This chapter describes how to upgrade your Arcadia Central Station license. It contains the following sections:

12.1 Port Licenses	133
12.2 Online Activation of Additional Licenses	133
12.3 Offline Activation of Additional Licenses	134

12.1 Port Licenses

The Arcadia Central Station is available with several port licensing options:

- 16 ports
- 32 ports
- 48 ports
- 64 ports
- 80 ports
- 96 ports
- 112 ports
- 128 ports

You can purchase additional port capacity in 16-port bundles to a maximum of 128 ports.

Additional 16-port bundles are available from your Clear-Com dealer. When you purchase additional port bundles, Clear-Com will send you a code for your licenses that can be activated in the CCM of your Arcadia Central Station.

12.2 Online Activation of Additional Licenses

Note: *You can activate licenses online if your PC and Arcadia Central Station have an Internet connection on the same network.*

1. Navigate to **Hardware > Resources > Host > License**, and select **Add licenses online**.

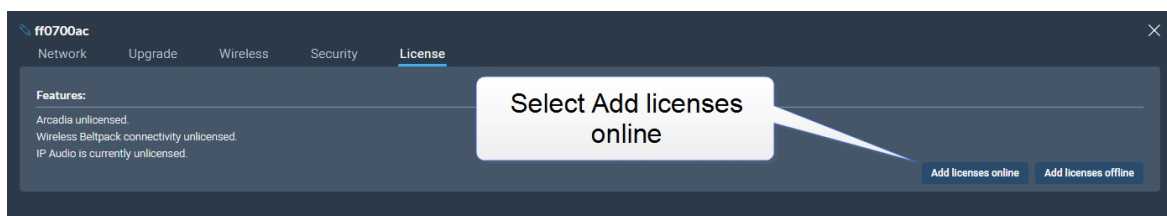

2. Enter the ticket you received from Clear-Com, and then select **Validate**.

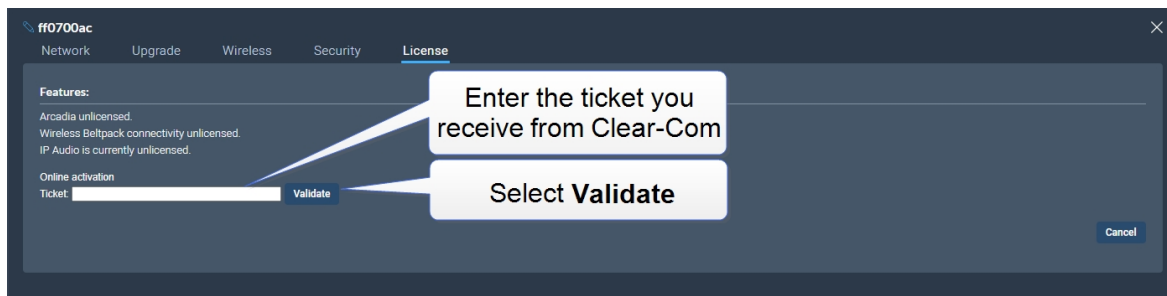

- Click the checkbox, select the quantity of 16-port bundles or feature licenses you wish to install and click **Activate**.

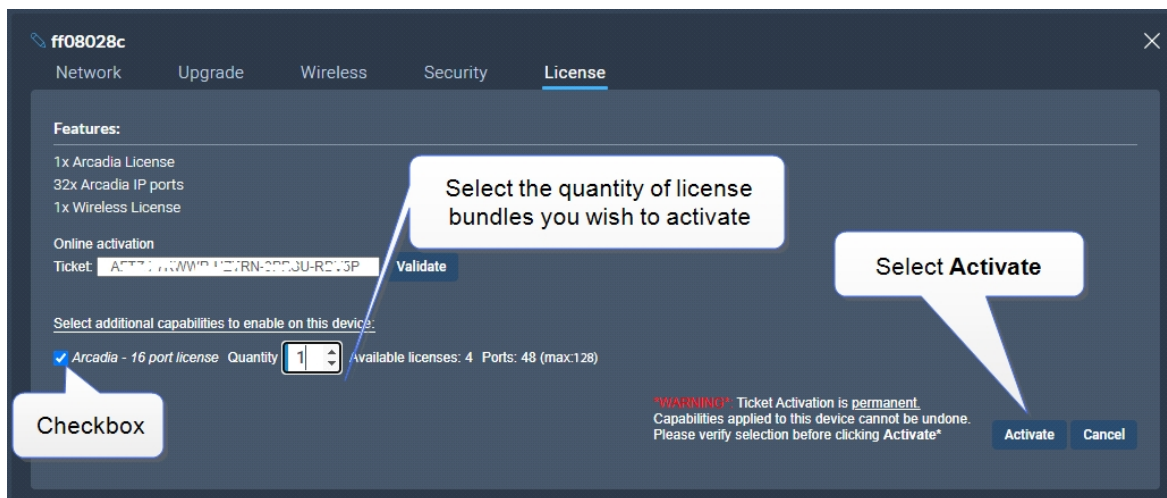

- You must reboot the Station before the licenses take effect. In the CCM, navigate to **Status > Overview > Host Device** and select **Reboot**.
- Once the licenses are activated, you will be able to see how many licenses you have in the **Hardware > Resources** page under **Licensed Ports**.

12.3 Offline Activation of Additional Licenses

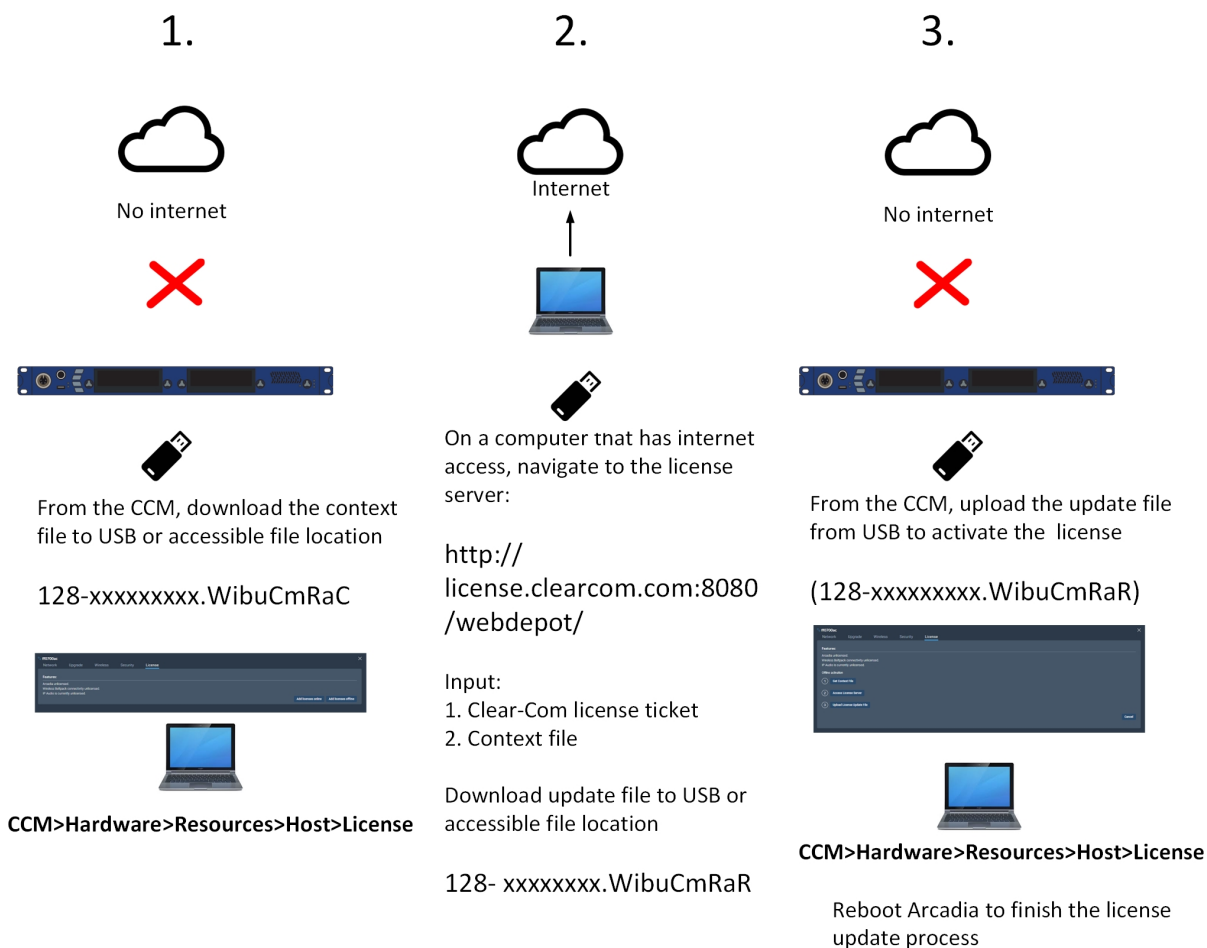

For detailed steps see below.

1. Navigate to **Hardware > Resources > Host > License**, and select **Add licenses offline**.

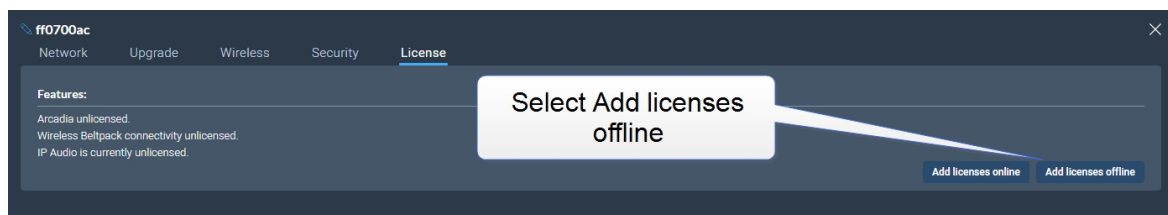

2. Select **Get Context File**.

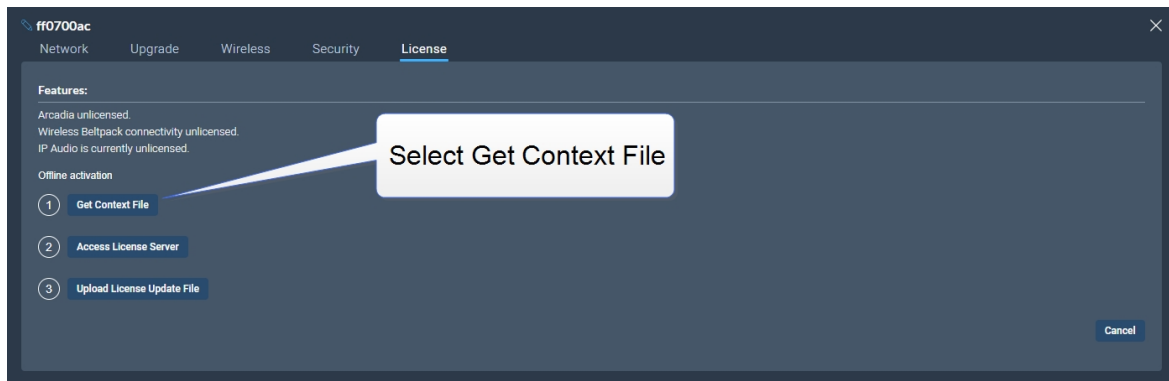

The context file downloads locally.

3. Use another PC which has internet access and connect a browser to <http://license.clearcom.com:8080/webdepot/>. As you will download the licenses into the previously downloaded context file (step 2) you need the context file on the new PC.
4. You will see the online license server. Enter your Clear-Com ticket number, and then Click **Next**.

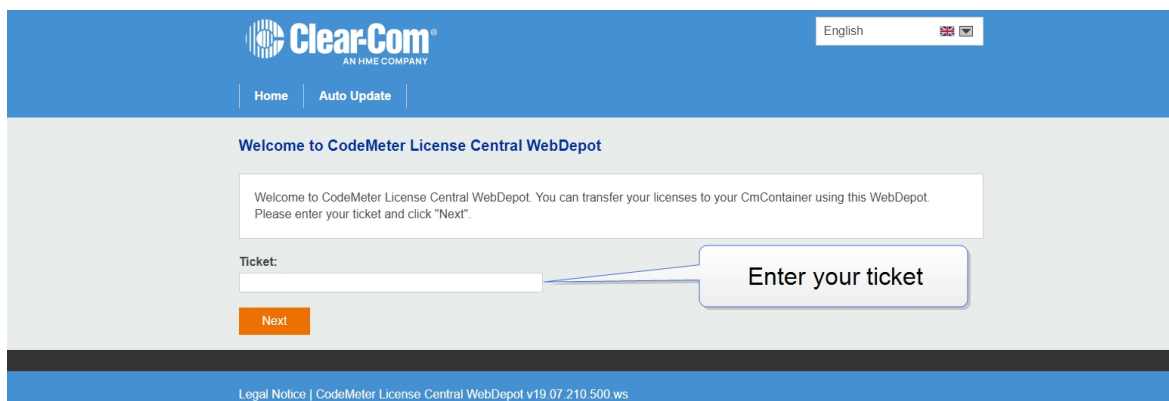

5. The licenses on your ticket are displayed on the screen. Select **Activate Licenses**.

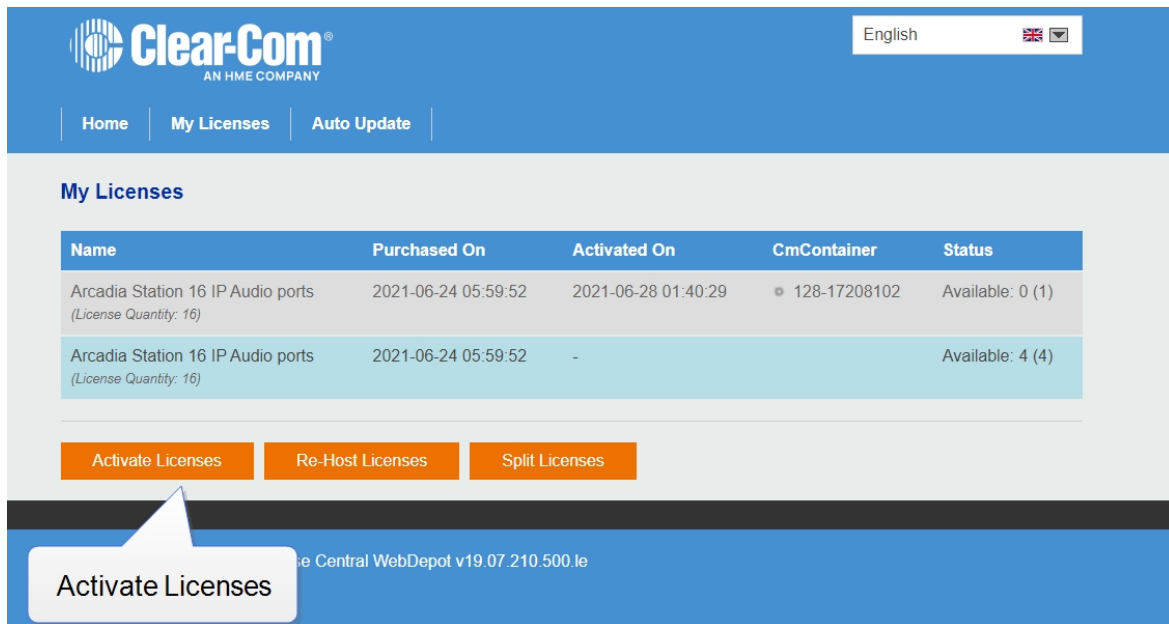

6. Select the left-hand option.

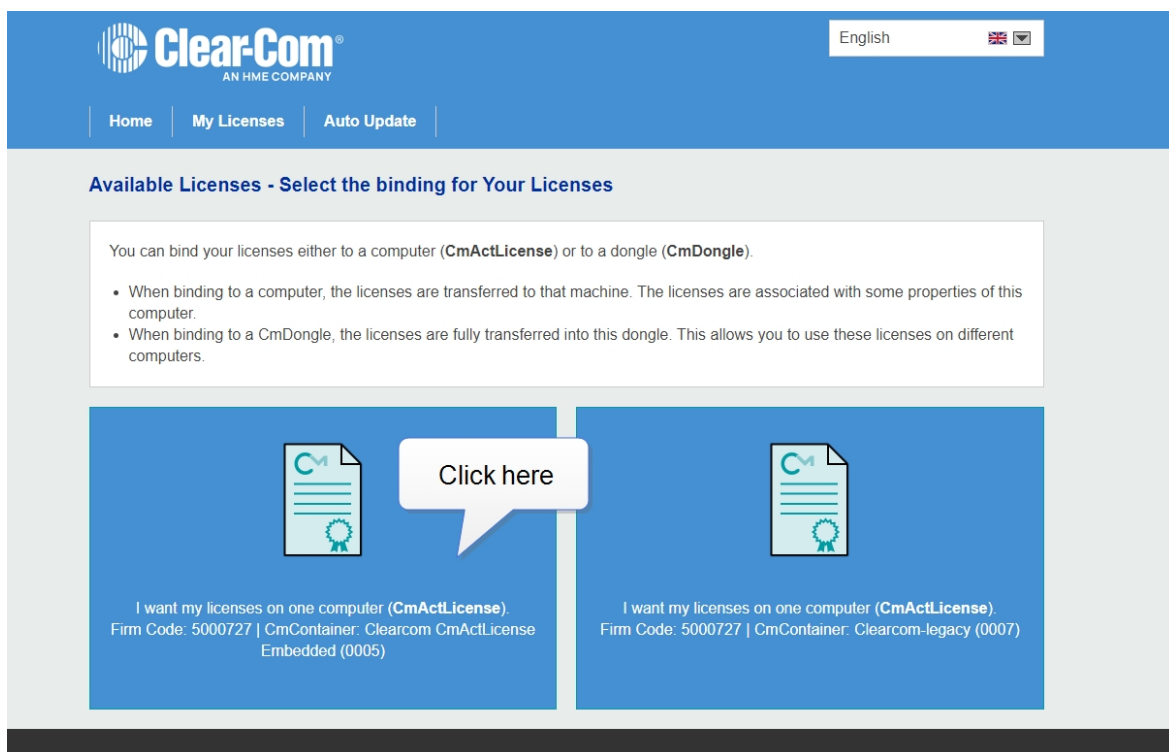

7. Click **File-based license transfer**.

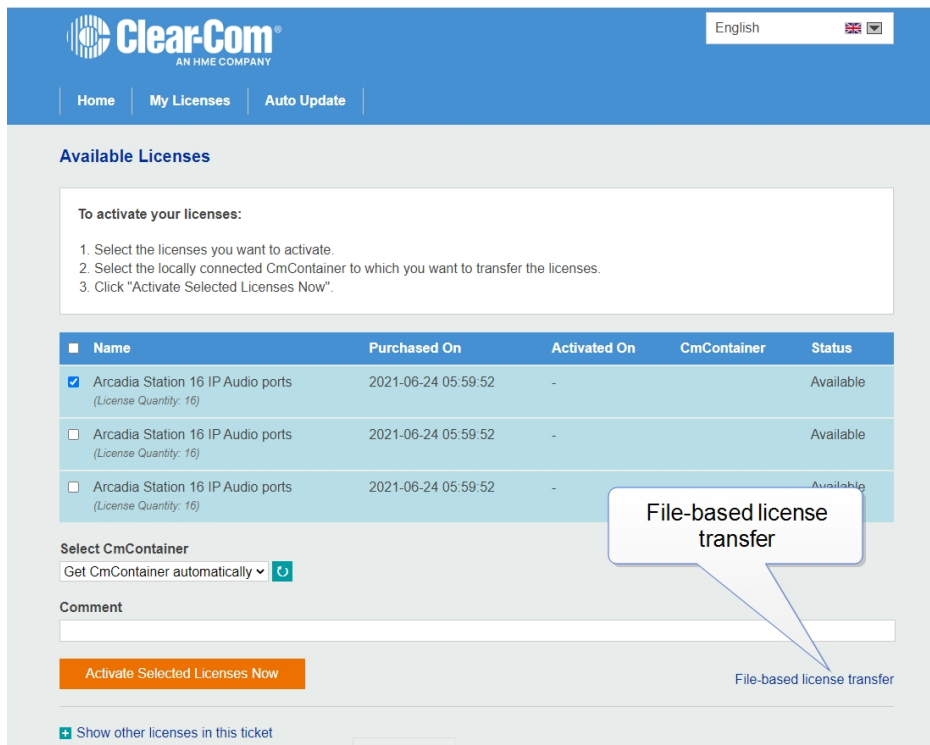

8. Select the required license(s). Click Choose File and navigate to the context file (downloaded in step 2). Select it. Then click **Start Activation Now**.

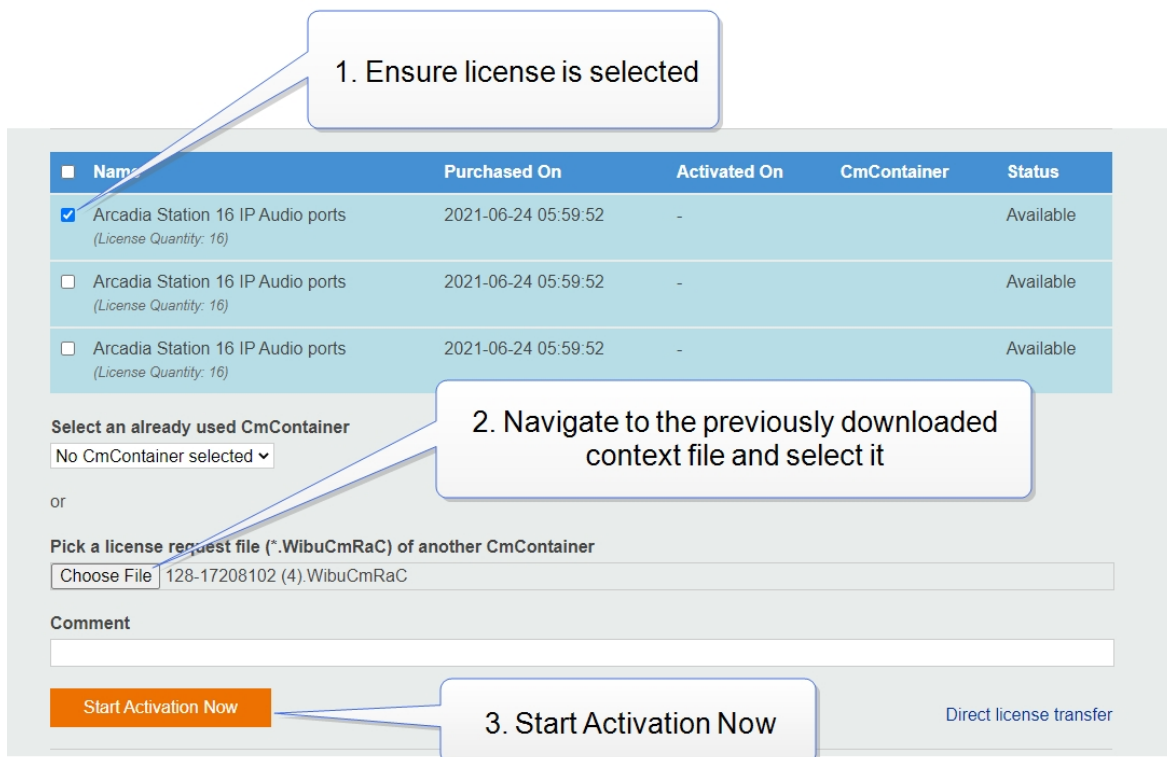

9. Download the License Update File
10. Do not **Upload Receipt Now**. Instead, return to the CCM and select **Upload License Update File**.

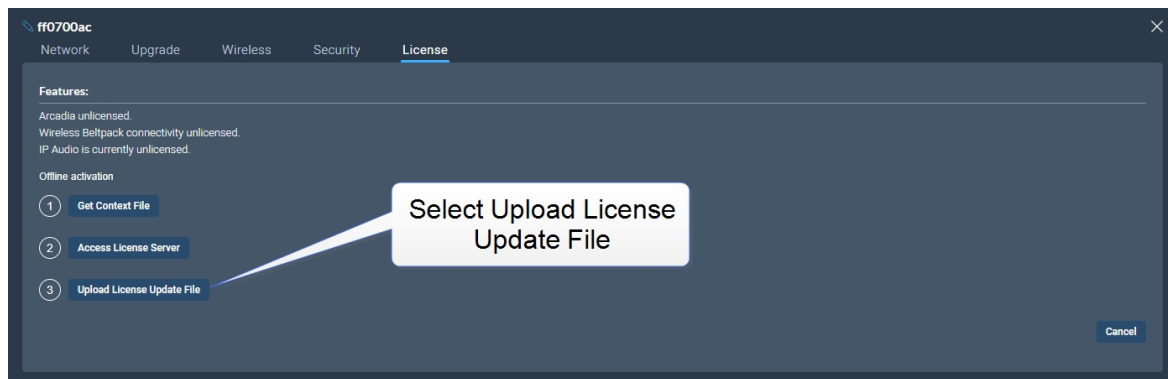

11. Navigate to where you have stored the downloaded file from Step 9 (128-xxxxxxx.WibuCmRaU). Select the file. The license will upload.
12. You must reboot the Station before the licenses take effect. In the CCM, navigate to **Status > Overview > Host Device** and select **Reboot**.
13. Once the licenses are activated, you will be able to see how many licenses you have in the **Hardware > Resources** page under **Licensed Ports**. You can also see licensed features on the **Hosts** panel in the same page.

13

Security

This chapter describes important security features. It contains the following sections:

13.1 Warning	141
13.2 Introduction	141
13.3 Using Security Certificates	142
13.4 Forcing HTTPS	142

13.1 Warning

The CCM ensures that you do not turn off port 80 without testing your certificate. If you turn off port 80 without ensuring that you can reach the CCM using port 433 it is possible to get locked out of your CCM. If this happens, you must reset the Arcadia Central Station from the front panel menus. This will remove all configuration, including network details from your Arcadia Central Station.

Note: *Some knowledge of certificate authorization and HTTPS is needed when setting up a secure connection between a PC hosting the Core Configuration Manager (CCM) and a Arcadia Central Station.*

Note: *Each browser type (for example, Safari, Chrome, Edge, Firefox) uses its own method for certificate management. These methods can change with time and is beyond the control of Clear-Com. Please refer to the instructions supplied with your browser if you require more information.*

13.2 Introduction

The following are some of the main security features.

13.2.1 Secure HyperText Transfer Protocol (HTTPS)

HTTPS is an adaptation of the HTTP protocol. It protects against an intermediary being able to intercept data between devices, using data encryption and Public Key Cryptography to create a secured channel.

13.2.2 Using HTTPS With Your Arcadia® Central Station

When using the CCM to establish your intercom setup, you might wish to protect your login credentials and configuration details from unauthorized interference. In this case you will establish an encrypted connection between the CCM and your Arcadia Central Station using the **Force HTTPS** feature.

13.2.3 The Force HTTPS Feature

The Arcadia Central Station uses port 80 (HTTP) and port 433 (HTTPS) for management. If you wish to create a secured route for data between the CCM and the Arcadia Central Station you must:

- Install a security certificate
- Turn off port 80, forcing traffic to use port 433

This creates a certified and encrypted connection between the Arcadia Central Station and the PC accessing the CCM.

13.3 Using Security Certificates

There are three types of security certificate available. Choose the certification option that best suits your security requirements:

- A certificate of your own choosing (full chain and private key)
- An EasyDNS authorized certificate for *.clearcomdevices.com (this option requires you to register your Arcadia Central Station with a DNS server) and cannot be used unless your Arcadia Central Station has internet access
- The Clear-Com self-signed certificate

More detail about certificates:

1. **A certificate of your own choosing.** This option gives you complete control over the security of your Arcadia Central Station. This option requires specialized knowledge about how to obtain a fullchain certificate and private key, and how to install them on your browser. When using your own certificate you might have to provide a DNS server address and register the Arcadia Central Station.
2. **The EasyDNS certificate.** This is a commercial certificate. When using the EasyDNS certificate you have to have a DNS server address for Arcadia Central Station registration and a gateway for your device in order for the browser to verify the certificate with AlphaSSL and GlobalSign.
3. **The Clear-Com self-signed certificate (default).** This certificate can be used in a private network (does not require Internet access to verify the certificate). It can also be used to perform an initial test of your security setup. **Warning:** Browsers can be configured to trust the self-signed certificate, but this process will vary between browsers.

13.4 Forcing HTTPS

1. Chose and install a security certificate on the PC or browser used to reach the CCM of the Arcadia Central Station. Clear-Com offers a choice of 3 different types of certificate, offering different levels of security.
2. Test the certificate by trying to reach the CCM on the HTTPS port. Type: **HTTPS:// device IP address** in the browser URL field and press the [Enter] key.

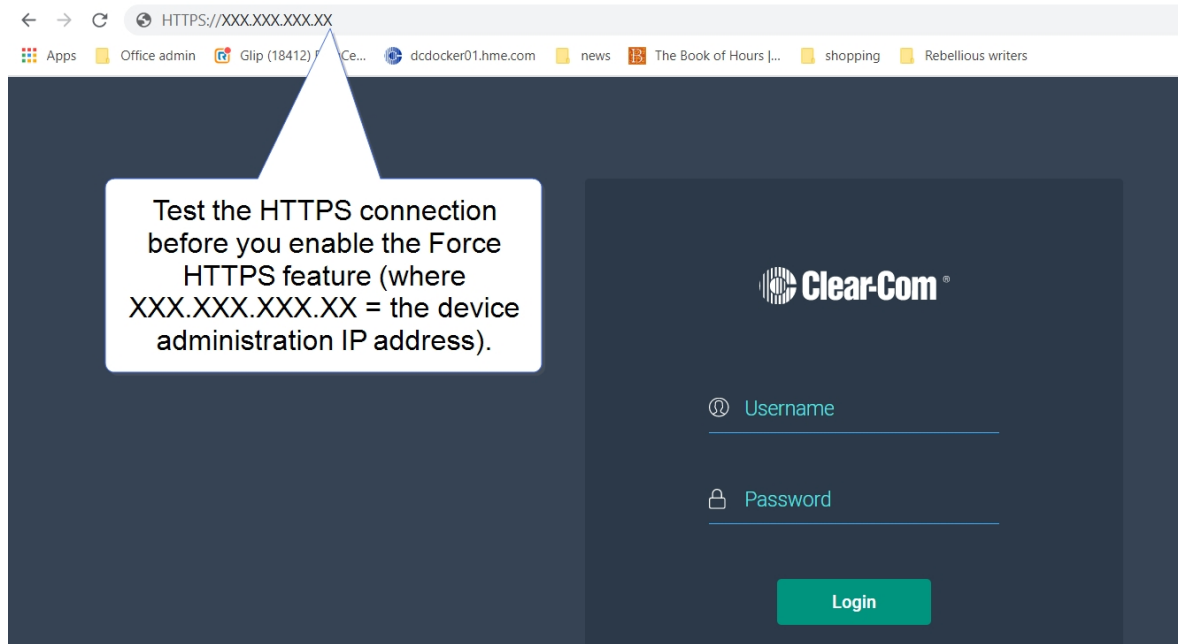

To enable **Force HTTPS** in the CCM navigate to: **Hardware > Resources > Host  > Security** and click to enable **Force HTTPS**. This turns port 80 off, forcing traffic to use port 433.

ff080238 ✕

Network Upgrade Wireless **Security**

General

i Info PLEASE CONNECT USING HTTPS BEFORE FORCING HTTPS. THIS IS TO ENSURE YOU WON'T HAVE CERTIFICATE VALIDATION ISSUES.

Force HTTPS Enabled Disabled

Default Certificate

The default certificate is used for internal traffic. Any other certificate loaded onto this unit will only be utilized for CCM.

	Regenerate
Certificate Status	Valid
Certificate Type	Self-signed
Certificate Authority	Clear-Com
Expiration Date	Jun 8 2023 --- 765 day(s) left.
CA Certificate	Download

Active Certificate

Use Default Certificate	Switch
Use EasyDNS Certificate	Switch
EasyDNS hostname	cc-fsebase-31zyf587-0.clearcomdevices.com

14 Appendix A: Pinouts

This chapter describes the pinouts of the connectors on the Arcadia® Central Station. It contains the following sections:

14.1 GPIO pinouts	146
14.2 2-Wire Pinouts	148
14.3 4-Wire Pinouts	149
14.4 DECT Sync	149

14.1 GPIO pinouts

GPIO 1 (Relay 1 &2)

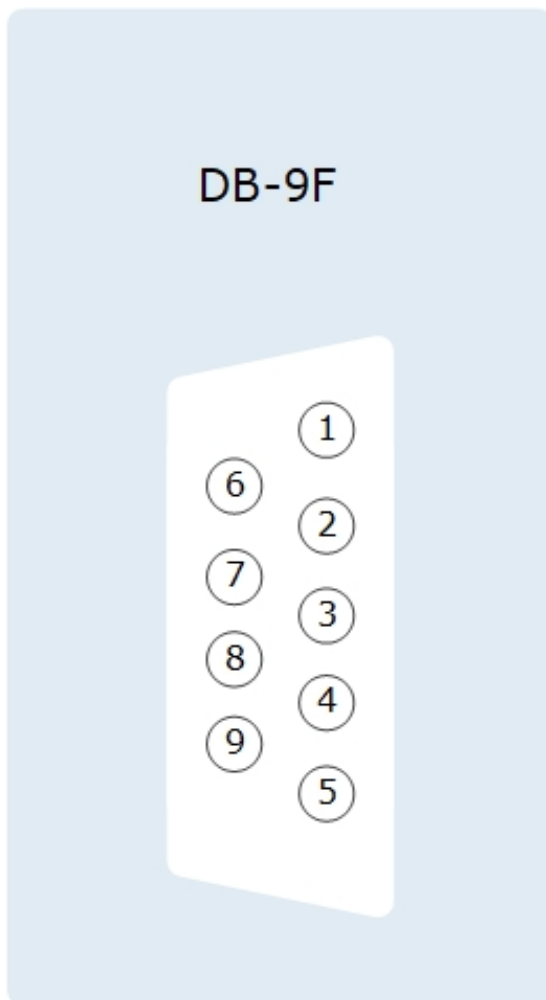

1. Relay 1 Common
2. Relay 1 Normally Closed
3. Relay 1 Normally open
6. Relay 2 Common
7. Relay 2 Normally Closed
8. Relay 2 Normally Open
4. Input A1
5. Input B1
9. 12V

Shield 0V

GPIO 2 (Relay 3 & 4)



- 1. Relay 3 Common
- 2. Relay 3 Normally Closed
- 3. Relay 3 Normally open
- 6. Relay 4 Common
- 7. Relay 4 Normally Closed
- 8. Relay 4 Normally Open
- 4. Input A2
- 5. Input B2
- 9. 12V

Shield 0V

Suggested wiring for a footswitch

From	To	
GPIO-DB9 pin 4 (input A1)	GPIO-DB9 pin 9 (+12V)	link (jumper) wire
GPIO-DB9 pin 5 (input B1)	footswitch	
GPIO-DB9 Shell (0V)	footswitch	

14.2 2-Wire Pinouts

14.2.1 Clear-Com 2-Wire XLR Pinout

1. Ground
2. DC power (30V)
3. Duplex audio

XLR3F

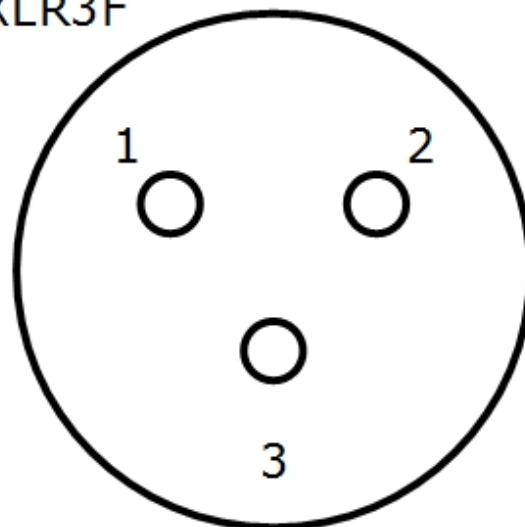

14.2.2 RTS 2-Wire XLR pinout

1. Ground
2. DC power (30V)
Duplex audio 1
3. Duplex audio 2

XLR3F

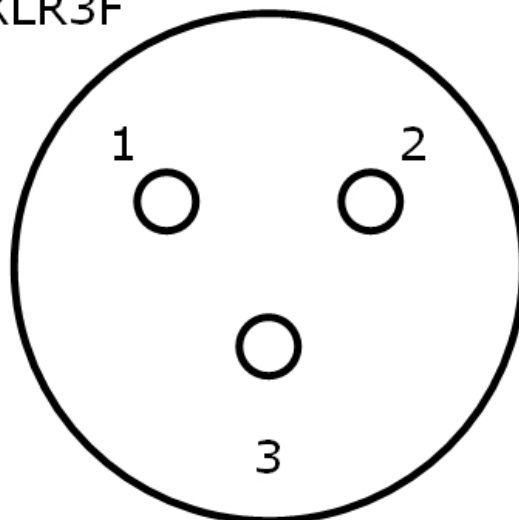

14.3 4-Wire Pinouts

Pin	4-wire	4-wire-X (default)
1	Data in +	Data out +
2	Data in -	Data out -
3	Audio in +	Audio out +
4	Audio out +	Audio in +
5	Audio out -	Audio in -
6	Audio in -	Audio out -
7	Data out +	Data in +
8	Data out -	Data in -

14.4 DECT Sync

Pin	Sync In	Sync Out
Pin 1	DECTSYNC IN +	DECTSYNC OUT +
Pin 2	DECTSYNC IN -	DECTSYNC OUT -
Pin 3	8 KHZ IN +	8 KHZ OUT +
Pin 6	8 KHZ IN -	8 KHZ OUT -

Caution: Shielded Cable Requirement

Shielded Cable is required for ALL FreeSpeak GPIO Port connectivity. CAT 5e Shielded Cable must be used to assure compliance with domestic and international emissions standards. Customers, Installers and or qualified Personnel failing to use shielded cables may cause radio interference in which case the user may be required to take adequate measures.

15 Appendix B: Specifications

This section contains a list of technical specifications for the Station. It contains the following subsections:

15.1 Arcadia® Central Station	151
15.2 Capacity	155
15.3 Network Specifications	156

15.1 Arcadia® Central Station

Specification	Value
Front panel headset	(1) 4-pin XLR-M or 5-pin XLR-M <ul style="list-style-type: none"> • auto headset detect
Front panel headset microphone input	<ul style="list-style-type: none"> • Input type: Dynamic /Electret - Selectable • Frequency response: headset mic - Partyline: 200Hz – 12 kHz + 3dBu • Frequency response: headset mic - Line Out: 200Hz – 20 kHz + 3dBu • Mic limiter threshold: -50dBu ±3dB • Mic limiter range: ≥ 20dB • Max input level: -25dBu • Input level: -60dBu nominal; -25dBu MAX • Headset mic voltage 5V (Electret selectable)
Front panel headset microphone output	<ul style="list-style-type: none"> • Load Impedance: > 32Ω • Output Impedance: 33Ω • Max Output Level before Distortion: >13 dBu • Total Harmonic Distortion (THD): < 0.1% THD at 1 kHz • Headset Mic - Partyline: -78 dBu (Clear-Com mode) • Headset Mic - Line Out: -60 dBu • Frequency Response: Partyline - Headset Out: 200Hz – 10 kHz + 3dBu

Specification	Value
Gooseneck microphone input	<ul style="list-style-type: none"> • Input type: Dynamic, Electret (selectable) • Frequency Response: Gooseneck Mic - Partyline: 200Hz – 12kHz + 3dBu • Frequency Response: Gooseneck Mic - Line Out: 200Hz – 20kHz + 3dBu • Mic Limiter Threshold: -35dBu ±3dB • Mic Limiter Range: ≥ 20dB • Max Input Level: -10dBu • Input Level: -45dBu nominal; -10dBu MAX • Headset Mic Voltage: 5V (Electret selectable)
Speaker Output	<ul style="list-style-type: none"> • Speaker Type: 1.6 x 2.8in oval • Load Impedance: 4Ω • Max Output Level before 1% Distortion: 18dBu ± 2dB • Total Harmonic Distortion (THD): < 0.5% THD at 1kHz • Max Speaker Level: 87dB ± 2dB SPL A Weighted at 3ft • Frequency Response: 100Hz – 10kHz ± 9dB
USB connector	USB type A
Front panel buttons	<ul style="list-style-type: none"> • MIC: Microphone ON/OFF button • Menu button • HDST: Headset ON/OFF button • Fn: Function button (not active)
Front panel rotary encoders	(5) Digital rotary encoders Operating level: 0dBu to + 18dBu, nominal, or -18dBu to +8dBu
Front panel touch screens	(2) 480 x 128 color TFT LED Touch Screen displays
Status LEDs	(2) Power supply status LEDs, (1) Arcadia Central Station status LED, (1) Volume level three color control LED array

Specification	Value
The Arcadia Central Station has two power supplies which can be used together to provide power redundancy.	
Power	<ol style="list-style-type: none"> 1. AC Mains input: 100-240V AC, 50-60Hz, 160W Max, IEC60320 C14 inlet. 2. DC Low Voltage Input: 12V DC +/- 5%, 12A
GPIO port	<p>(2) DB9F</p> <ul style="list-style-type: none"> • Relay contact type: SPDT • Relay quantity: 4 • Relay contact voltage rating: 30 VDC • Relay contact current rating: 1 A • Input type: Opto-Isolated • Input quantity: 2 • Input voltage range: 4 - 30 volts DC or AC • Input current: >=1.2mA required
2-wire I/O	<p>(4) XLR-3F</p> <ul style="list-style-type: none"> • 2-wire I/O: Selectable RTS or Clear-Com mode, software controlled null, null depth >60dB at 1kHz • 2-wire Power On/Off: A/B, C/D paired- software controlled • 2-wire Output Voltage: 25 – 28 VDC, 560 mA per pair (A/B or C/D) • 2-wire Impedance: >10kΩ • 2-wire Operating Levels: -18dBu nominal (Clear-Com Mode), -12dBu nominal (RTS Mode), Headroom 18dB • 2-wire Frequency Response: 200 to 12kHz. ±3dB • 2-wire Total Harmonic Distortion (THD): < 0.1% THD at 1 kHz

Specification	Value
4-wire I/O	(8) RJ45 <ul style="list-style-type: none"> • 4-wire I/O: Output Impedance >10kΩ, Input Impedance 200Ω + 10%, transformer isolated balanced input and output. • 4-wire Operating Levels: 0dBu Nominal, 18dBu headroom • Port 8 used for stage announce and program feed
Stage announce and program feed	(1) Cable assembly CAB-RJ45-PGM-SA provided. Connects to RJ45 (port 8 on the Station) <ul style="list-style-type: none"> • XLR-3F labeled PGM input • XLR-3M labeled SA output Program Input level control via rotary encoder.
DECT Sync IN/OUT	(2) RJ45 sync input and output
E1 Splitter/transceiver ports	(2) RJ45 (2) Fiber, to be used with SFP module Note: only 2 splitter ports active at any one time and these must both be EITHER RJ45 OR Fiber.
LAN connectors	(2) RJ45 (2) Fiber, to be used with SFP module All 4 LAN ports are fully user configurable, to be split between management, AES67 and Dante traffic.
Dimensions	1 RU: h.44 x w.483 x d. 355 mm (1.75 x 19 x 14 inches)
Weight	Approx 3.3 kg (7.25 lb)
Frequency response - station to beltpack	
Arcadia Central Station to beltpack frequency response	<ul style="list-style-type: none"> • FreeSpeak II beltpacks: 200 Hz - 7.5 kHz • FreeSpeak Edge beltpacks: 200 Hz - 12 kHz

15.2 Capacity

Specification	Value
Number of transceivers supported by Arcadia Central Station	26 in total <ul style="list-style-type: none"> • 16 IP transceivers (FreeSpeak II or FreeSpeak Edge) • E1 transceivers, 2 connected directly to the Arcadia Central Station, 10 via a splitter
Number of FreeSpeak beltacks per Arcadia Central Station	Up to 40 beltacks in total, made up of either FreeSpeak II or FreeSpeak Edge beltacks
Number of HelixNet user stations per Arcadia Central Station	Up to 64 made up of beltacks, remote stations, speaker stations
Audio Channels	Max 100
Channels enabled for use with HelixNet	Max 24
Groups	Max 100
GPIOs	2 x GPI, 4 x GPO

15.3 Network Specifications

Specification	Value
AoIP Interface Protocols	<ul style="list-style-type: none"> • RTSP/SAP • AES67 • Dante
Audio Sampling	24-bit Linear 48KHz
IP Addressing	<ul style="list-style-type: none"> • Static • DHCP
Network Compatibility	Layer 2 and Layer 3 only
Quality of Service	DiffServ RFC2474
IGMP	On (AoIP)
Multicast	On (AoIP)
Network Timing	PTPv2 (AoIP)/PTPv1 (Dante)
Perduplex Connection	<ul style="list-style-type: none"> • 1 x FS II IPT bandwidth usage: ~7 Mbps • 1 x FS Edge IPT: ~9.6 Mbps
Network Protocols	<ul style="list-style-type: none"> • Ethernet IPv4 Unicast Audio and Control • mDNS-Multicast Device Discovery
Network Ports	<ul style="list-style-type: none"> • Unicast: • Port 80 TCP - Web Interface, System Management, Expansion • Port 443 for HTTPS • Port 6001 UDP - AES67 Data • Port 15000 - 15256 UDP - AES67 Audio
	<p>Multicast:</p> <p>Port 5353 UDP - mDNS, Names, Discovery, Linking, Expansion, Dante (through various ports)</p>

Specification	Value	
Network Jitter Tolerance	< 1µs required for RF Syncing of Transceivers	
Recommended Ethernet Switches	<ul style="list-style-type: none"> • Managed Ethernet Switch - Layer 3 • 1000 Base - T ports for endpoints • 1000 Base IP Trunks between switches • QoS Configuration • Energy Efficient Ethernet bypass option • IGMP Snooping bypass option 	
QoS Tags for AoIP		
Clock	IEEE 1588-2008 Announce, Synch, Follow_Up, Delay_Req, Delay_Resp, Pdelay_Req, Pdelay_Resp and Pdelay_Resp_Follow_Up packets	EF (46) (Expedited Forwarding)
Media	RTP and RTCP media stream data	AF41 (34) (Assured Forwarding)
Best Effort	IEEE 1588-2008 signaling and management messages. Discovery and connection management messages.	DF (0) (Default Forwarding)
QoS Tags for Dante		
High	Time Critical PTP Events	CS7 (56)
Medium	Audio, PTP	EF (46) (Expedited Forwarding)
Low	Reserved	CS1 (8)
None	Other Traffic	Best Effort (0)

Appendix C: Spare Parts

Part	Part Number
External power supply, 12VDC 150W	PSU-EXT-0001
Split cable, RJ45 to PGM and SA	CAB-RJ45-PGM-SA
Fan plate assembly	T40020-1
Rack ear (x1)	272G162-SP
Encoder cap (x1)	272G286-SP
Optional equipment	
Ethernet fiber modules*:	
1 Gbps SM SXFIBER SFP	SFP-SMFO-1G-LX
1 Gbps MM LXFIBER SFP	SFP-MMFO-1G-SX
PSU Mounting Bracket	272G048-SP
Arcadia® Central Station User Guide	PUB-00021

*There is a detailed list of all Clear-Com SFPs (including range, wavelength and speed) on the [FreeSpeak II Knowledge Center](#).

17 Appendix D: Front Panel Menu Reference Tables

This chapter lists the front panel menu options. It contains the following sections:

17.1 Audio Settings	160
17.2 Host Settings	160
17.3 2 W Audio (A/B) (C/D)	161
17.4 Discovery	161
17.5 Transceiver	162
17.6 Networking	163
17.7 Administration	164

Note: Default values are shown in **bold**.

17.1 Audio Settings

Level 1	Level 2	Level 3	Level 4
Audio	Headset	Headset Limit	8 to -12 dB/Off Default = 0 dB
		Headset detect	Enabled/Disabled
		HS Mic Type	Electret/ Dynamic
		Sidetone Gain	8 to -12 dB Default = -12
		Sidetone Control	Tracking/Non-Tracking/Disabled
	Gooseneck	GN Mic Type	Electret
			Dynamic

17.2 Host Settings

Level 1	Level 2	Level 3	Level 4
Host Settings	Host name	Edit	Press controller 4 to open a touchscreen keyboard.
	Display	Screen Brightness	High/ Medium /Low/Very Low
		Screen Dimming	1 to 15 minutes Default = 2 minutes
		Touchscreen sensitivity	Low, Medium , High

17.3 2 W Audio (A/B) (C/D)

Level 1	Level 2	Level 3	Level 4
2W Audio (A / B)	Interface	Power detected	Yes/No
		Power	Enabled/ Disabled
		Mode	Clear-Com /RTS
	2W A	Nulling	The nulling function is only available if power is detected.
	2W B	Nulling	as above
Audio (B / C)	Same as Audio (A / B)		

17.4 Discovery

Level 1	Level 2	Level 3	Level 4
Discovery	Discover FSII IP TCVR	Discovered FSII IP TCVRs	Register/Unregister
	Discover FSE TCVR	Discovered FSE TCVRs	Register/Unregister

17.5 Transceiver

Level 1	Level 2	Level 3	Level 4
Transceiver	TCVR 1 ... XX View configured transceivers. Max: <ul style="list-style-type: none"> • E1; 10 • IP TCVRs; 6 	Version	
		Label	
		Cable Comp (E1 only)	0 - 69 m , 70 - 139 m, 140 - 209 m, 210 - 279 m, 280 - 349 m, ... (increments of 70 m) up to 1540 - 1609 m

17.6 Networking

Level 1	Level 2	Level 3	Level 4
Networking	Management	LAN Status	Up/Down
		LAN Port	LAN Ports 1 - 4
		DHCP	Enabled/Disabled
		IP Address	
		Subnet mask	
		MAC	
	AES67 (only visible if AES67 has been configured to its own LAN)	LAN Status	Up/Down
	Dante (only visible if Dante has been configured in the CCM)		
		LAN Port	By default management and AES67 are configured to LAN 1. This can be changed in the CCM.
		DHCP	Enabled/Disabled
		IP Address	
		Subnet mask	
		MAC	MAC address

17.7 Administration

Level 1	Level 2	Level 3	Level 4
Administration	Beltpacks	Over The Air	Start OTA
		BP Role List Sorting	Sort by Role Number /Alphabetical
		Battery Type	Alkaline /NiMh (for use when not using the supplied Li-ion type batteries)
	Software	Current	View current version
		Update	Use this to update the Arcadia Central Station using a USB stick.
	License	Connections	View connected ports

Level 1	Level 2	Level 3	Level 4
		Licensed Ports	View licensed ports: <ul style="list-style-type: none"> • Total Ports • Wireless Ports • HelixNet ports • Dante Ports • Any Ports. Ports configured to Any will accept connections of any type: FreeSpeak, HelixNet or Dante
	Reset	Reboot	Press rotary 4 to reboot now
		Reset to Default	Reset Base. When you reset the Base here, as well as system setup details (channels and roles), network details (IP addresses) are also reset. This is not the case when resetting the Base in the CCM. After resetting you must Add transceivers again. HelixNet connections revert to default config.

Level 1	Level 2	Level 3	Level 4
		Reset CCM Password	Press rotary 4 to reset CCM password to the default setting.
	Support Info	Generate	Insert USB
	Settings	Save Restore	Insert USB
	CCM Access	Username Default password	
	Hardware	Hw Info Hw Version BOM number PCB number Serial number Product number	Read only. Serial number here is the number of the electronic main board, not the Arcadia device.

18 Appendix E: Regulatory Compliance (Regulatory Model: 1410)

This chapter describes the regulatory compliance for the Arcadia Central Station. It contains the following sections:

18.1 FCC Notice	168
18.2 FCC/IC/EC RF Exposure Warning	169
18.3 Industry Canada Compliance Statement	169
18.4 Korean Notice	169
18.5 European Union (CE mark)	170
18.6 United Kingdom (UKCA Mark)	170
18.7 Electrical and Electronic Equipment (WEEE) Waste	171

Applicant Name: Clear-Com LLC

Applicant Address: 1301 Marina Village Pkwy, Suite 105, Alameda CA 94501, United States

Manufacturer Name: Clear-Com LLC

Manufacturer Address: 1301 Marina Village Pkwy, Suite 105, Alameda CA 94501, United States

Country of Origin: USA

Brand: Clear-Com

Caution: All products are compliant with regulatory requirements detailed in this document when the user follows all installation instructions and operating conditions per Clear-Com specifications

Caution: Use of accessories and peripherals other than those recommended by Clear-Com may void the product's compliance as well as the user's authority to operate the equipment.

18.1 FCC Notice

This device complies with Part 15 of the FCC rules. Operation is subject to the following two conditions: (1) This device may not cause harmful interference, and (2) This device must accept any interference received, including interference that may cause undesired operation.

NOTE: This equipment has been tested and found to comply with the limits for a Class A digital device, pursuant to Part 15 of the FCC rules. These limits are designed to provide reasonable protection against harmful interference when the equipment is operated in a commercial environment. This equipment generates, uses and can radiate radio frequency energy and, if not installed and used in accordance with the instruction manual, may cause harmful interference to radio communication. Operation of this equipment in a residential area is likely to cause harmful interference, in which case the user will be required to correct the interference at his own expense.

Changes or modifications not expressly approved by Clear-Com, LLC, an HM Electronics, Inc. company could void the user's authority to operate this equipment.

18.2 FCC/IC/EC RF Exposure Warning

- This product complies with FCC/IC/EC radiation exposure limits set forth for an uncontrolled environment.
- Produits Clear-Com sont conformes aux limites IC d'exposition aux rayonnements définies pour un environnement non contrôlé.
- This product may not be co-located or operated in conjunction with any other transceiver or transmitter.
- Ce produit ne peut pas être co-localisé ou utilisé en conjonction avec un autre émetteur-récepteur ou émetteur.
- To comply with FCC/IC/EC RF exposure requirements, the Antenna/Transceiver unit must be installed and operated at least 20 cm (8 inches) from any person.
- Produits Clear-Com doivent être installés et utilisés avec distance minimum de 20cm entre le radiateur et votre corps.

18.3 Industry Canada Compliance Statement

This Class[A] digital device complies with Canadian ICES-003.

Avis de conformité à la réglementation d'Industrie Canada

Cet appareil est conforme aux CNR d'Industrie Canada applicables aux appareils radio exempts de licence. L'exploitation est soumise aux deux conditions suivantes:

- (1) cet appareil ne doit pas provoquer d'interférence, et
- (2) cet appareil doit accepter toute interférence radioélectrique subie, même si l'interférence est susceptible d'en compromettre le fonctionnement.

Cet émetteur exempt de licence est équipé d'une antenne intégrée. Cet émetteur exempt de licence n'est pas autorisé à fonctionner avec une autre antenne.

Cet appareil numérique de la class[*] est conforme à la norme NMB-003 du Canada.

18.4 Korean Notice

A급 기기 (업무용 방송통신기자재)

이 기기는 업무용(A급)으로 전자파적합기기로서 판매자 또는 사용자는 이 점을 주의하시기 바라며, 가정외의 지역에서 사용하는 것을 목적으로 합니다.

18.5 European Union (CE mark)

The CE marking indicates compliance with the following directives and standards, whenever applicable to the product in question.

Directives:

- Radio Equipment Directive 2014/53/EU
- Electromagnetic Compatibility Directive 2014/30/EU
- Low Voltage Directive 2014/35/EU
- RoHS Directive 2011/65/EU, 2015/863/EU

Standards:

- EN55032
- EN55035
- IEC/EN62368-1
- EN300328
- EN301489
- EN50581



18.6 United Kingdom (UKCA Mark)

The UKCA (UK Conformity Assessed) marking is a new UK product marking that will be used for goods being placed on the market in Great Britain (England, Wales and Scotland). The UKCA marking alone cannot be used for goods placed on the Northern Ireland market, which require the CE marking or UK(NI) marking.



Warning:

This is a Class A product. In a domestic environment this product may cause radio interference in which case the user may be required to take adequate measures.

18.7 Electrical and Electronic Equipment (WEEE) Waste

The European Union (EU) WEEE Directive (2012/19/EU) places an obligation on producers (manufacturers, distributors and/or retailers) to take-back electronic products at the end of their useful life. The WEEE Directive covers most Clear-Com products being sold into the EU as of August 13, 2005. Manufacturers, distributors and retailers are obliged to finance the costs of recovery from municipal collection points, reuse, and recycling of specified percentages per the WEEE requirements.

Instructions for Disposal of WEEE by Users in the European Union

The symbol shown below is on the product or on its packaging which indicates that this product was put on the market after August 13, 2005 and must not be disposed of with other waste. Instead, it is the user's responsibility to dispose of the user's waste equipment by handing it over to a designated collection point for the recycling of WEEE. The separate collection and recycling of waste equipment at the time of disposal will help to conserve natural resources and ensure that it is recycled in a manner that protects human health and the environment. For more information about where you can drop off your waste equipment for recycling, please contact your local authority, your household waste disposal service or the seller from whom you purchased the product.

