

**RS-602/622**  
**BELTPACKS**

**INSTRUCTION MANUAL**

RS-602/622 Instruction Manual  
©2005 Vitec Group Communications Inc.  
All Rights Reserved

Part Number 810288, Rev. B

Vitec Group Communications  
4065 Hollis Street  
Emeryville, CA 94608-3505  
U.S.A

**Clear-Com** is a registered trademark of Vitec Group  
Communications

The Clear-Com **Logo** is a registered trademark of Vitec  
Group Communications

**Windows** is a registered trademarks of Microsoft Corp.

# CONTENTS

<b>INTRODUCTION</b> . . . . .	<b>1</b>
<b>QUICK START</b> . . . . .	<b>3</b>
<b>OPERATING YOUR BELTPACK</b> . . . . .	<b>5</b>
Beltpack Compatibility . . . . .	5
Controls and Adjustments . . . . .	5
<b>CONNECTING YOUR BELTPACK</b> . . . . .	<b>17</b>
Intercom Connector . . . . .	18
Loop-Through Connector . . . . .	20
Program-Audio Volume Control . . . . .	21
Auxiliary (“AUX”) Headphone . . . . .	21
Headset Connector . . . . .	22
<b>CUSTOMIZING YOUR BELTPACK</b> . . . . .	<b>25</b>
V-Pack Software . . . . .	26
Onboard Programming . . . . .	27
Understanding Modes . . . . .	27
Selecting a Mode . . . . .	28

Editing a Mode's Settings . . . . .	30
Restoring the Factory Default Settings . . . . .	31
Settings You Can Customize . . . . .	32
Mode Select . . . . .	33
Latch Disable . . . . .	33
Call-on-Talk . . . . .	33
Electret Microphone . . . . .	34
Audible Call Signal . . . . .	34
Channel Swap . . . . .	35
Channel Exclusive . . . . .	35
Split-ear Headset (RS-622 only) . . . . .	36
Lockout . . . . .	36

<b>SPECIFICATIONS . . . . .</b>	<b>37</b>
---------------------------------	-----------

<b>MAINTENANCE . . . . .</b>	<b>41</b>
------------------------------	-----------

<b>WARRANTY . . . . .</b>	<b>47</b>
---------------------------	-----------

# INTRODUCTION

Thank you for choosing this product. Clear-Com designed the 600 series of beltpacks to meet the needs of all beltpack users, from beginners to experienced professionals. For advanced users, the 600 series provides the most advanced level of functioning available.

You can choose from among seven different versions of beltpacks, including single and dual-channel units, featuring both Clear-Com and TW (two-wire) compatibility.

## RS-600 SERIES

All RS-600 series beltpacks offer the following features:

- Rugged, compact design
- Full compatibility with all existing Clear-Com party-line systems
- Four setup configurations that you can activate directly from the beltpack
- Extra 2.5 mm cell-phone type headset jack
- Advanced setup options with V-Pack software

# RS-602 AND RS-622 BELTPACKS

The RS-602 and RS-622 beltpacks add the following features:

- Two intercom channels
- Local input for program audio
- “Loopable” program audio; you can connect program audio to other beltpacks in a “daisy-chain” configuration
- Program audio volume control
- RS-602 offers monaural headset connector
- RS-622 offers binaural headset connector
- 6-pin Switchcraft-style intercom connectors

# QUICK START

To start using your beltpack immediately:

1. Connect the appropriate 6-pin XLR line cables from an active intercom line to the beltpack.

*Note: The beltpack's intercom connectors use the Switchcraft-style 6-pin configuration. If ordering Neutrik 6-pin plugs to make a cable or patch panel, specify that you need the Switchcraft pin configuration. This configuration usually has an "S" suffix at the end of the Neutrik model number.*

2. Turn down the beltpack's incoming volume on each intercom channel with the channel A and channel B volume-control knobs.
3. Plug in a headset equipped with a dynamic microphone to the beltpack's main headset jack.

The headset jack is labeled on the back of the beltpack.

4. To talk on an intercom channel, press and hold the talk button for the desired channel. Speak into the microphone in your headset.

*Note: If you tap the talk button twice in quick succession, the talk button locks to the "on" setting ("latches") for hands-free use. Press the talk button again to unlatch it.*

5. Adjust the sidetone and incoming volume levels for both channels as you and others on the channels speak at the anticipated levels for the application.
6. To send a call signal, press the button labeled “call” for the appropriate channel.



# OPERATING YOUR BELTPACK

## BELTPACK COMPATIBILITY

The RS-602 and RS-622 belt packs work with all previous versions of standard Clear-Com party-line stations and belt packs, as long as you use proper cabling and 6-pin connectors. These models are not designed for use on a two-wire (TW) line. If you use these belt packs on a TW line, the audio on channel A of the TW line will be lost.

The RS-603 series of belt packs operate on TW lines. See the RS-603 series manual for more information.

## CONTROLS AND ADJUSTMENTS

Figures 1 and 2 illustrate the belt pack's onboard controls and adjustments.

### **I** Talk Lights, Channels A and B

A channel's green talk light illuminates when you press or latch that channel's talk button.

Some onboard programming options can change the function of this light. For more information about onboard programming, refer to the chapter “Customizing Your Beltpack.”.

- 1 Talk lights, channels A and B
- 2 Talk buttons, channels A and B

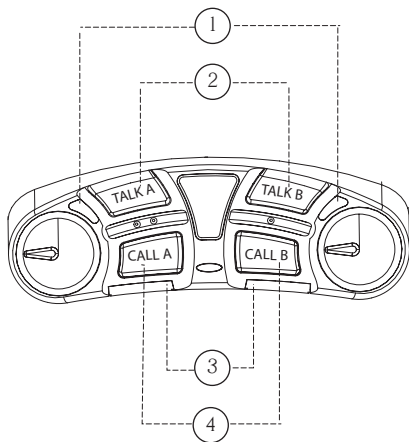

- 3 Call lights, channels A and B
- 4 Call buttons, channels A and B

*Figure 1: RS-602/622 Control Panel*

## **② Talk Buttons, Channels A and B**

To talk on an intercom channel, press and hold that channel's talk button while speaking into the microphone in your headset. While you hold the button, your voice transmits to the intercom channel. When you release the button, your voice no longer transmits to the intercom channel.

To “latch” a talk button “on” for hands-free use, quickly tap the button twice. To unlatch the talk button, press the button again.

With the V-Pack programming software, you can program a talk button to latch with a single or double tap, or not to latch at all. See “Customizing Your Beltpack” for more information.

## **③ Call Lights, Channels A and B**

A channel's call light illuminates when you send or receive a call signal on that channel.

Some onboard and computer programming options can change the function of this light. See “Customizing Your Beltpack” for more information.

#### ④ Call Buttons, Channels A and B

When you press a channel's call button, a call signal is sent to all other stations on that channel. Pressing the Call A button sends a call signal on channel A. Pressing the Call B button sends a call signal on channel B.

A channel's call light glows red to indicate both outgoing and incoming call signals on the channel.

---

- 5 Volume-control knob, channel A
- 6 Volume-control knob, channel B
- 7 Power-status light
- 8 Setup information window

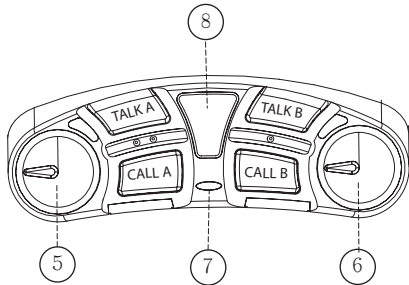

Figure 2: RS-602/622 Control Panel

*Note: Depending on the type and length of cables attached to the beltpack, crosstalk between cables may cause both channels to indicate a 20 kHz AC call signal that is sent on only one channel.*

### **⑤ Volume-Control Knob, Channel A**

The volume-control knob for channel A adjusts the incoming volume level (“listen level”) for that channel.

There is a limiter built into the beltpack circuitry to prevent incoming volume from exceeding a safe level. You can suspend this limit with the V-Pack software.

The volume A control knob also adjusts the mic gain (either main or auxiliary). Refer to the chapter “Customizing Your Beltpack” for more information.

### **⑥ Volume-Control Knob, Channel B**

The volume-control knob for channel B adjusts the incoming volume level (“listen level”) for that channel.

There is a limiter built into the beltpack circuitry to prevent incoming volume from exceeding a safe level. You can suspend this limit with the V-Pack software.

## ⑦ Power Status Light

An illuminated power status light indicates that the beltpack is connected to a powered intercom line.

**Note:** The light may illuminate even if the beltpack is receiving less than the minimum 12 VDC required for beltpack operation.

## ⑧ Setup Information Window

When you press and hold the setup button for more than three seconds, the setup information window lights up and displays current beltpack programming information.

If you do not select or program a feature within five seconds, setup is cancelled, and the setup information window dims to indicate that the setup mode is no longer available. This feature prevents changes if the setup button is pressed accidentally.

For more information on how to program features from your beltpack, see the chapter “Customizing Your Beltpack.”.

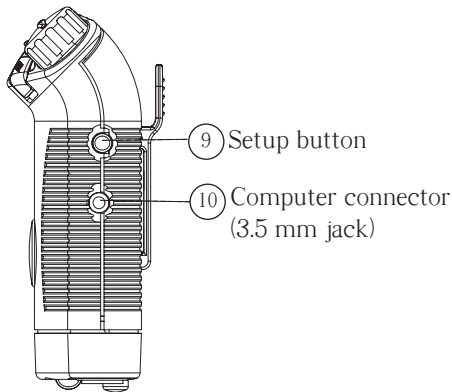

*Figure 3: Side panel of RS-602/622 Beltpack*

## **9 Setup Button**

When you press and hold the blue setup button for approximately three seconds, the beltpack enters “setup mode” during which you can select certain operating features for the beltpack.

Once setup mode is active, if you do not select or program a feature within five seconds, the setup mode deactivates, and the beltpack goes back to its normal state.

See the chapter “Customizing Your Beltpack” for information on programming your beltpack with this feature.

## **⑩ Computer Connector**

You can program your beltpack from a computer using the V-Pack™ programming software. To use this software you must first physically connect the beltpack to a computer with Clear-Com’s VPC-1 cable or its equivalent.

The VPC-1 cable has a tip-ring-sleeve 3.5 mm plug at one end for connecting to the beltpack, and a DB-9F plug at the other end for connecting to a computer’s serial port.

To connect the VPC-1 cable from your beltpack to a computer:

1. Plug the 3.5 mm plug at one end of the cable into the beltpack’s 3.5 mm jack located just under the setup button.



2. Plug the DB-9F plug on the other end of the cable into the DB-9M serial port socket on a computer.

If your computer has only USB connectors rather than a serial port, you must purchase a USB-to-serial port adaptor.

Contact your dealer or the Clear-Com factory for information about obtaining the beltpack programming kit, which contains the V-Pack software, VPC-1 cable, and V-Pack manual. You can also find a PDF of the V-Pack manual at [www.clearcom.com](http://www.clearcom.com).

<b>PIN</b>	<b>FUNCTION</b>
Tip	SDO to computer
Ring	SDI from computer
Sleeve	Ground

*Table 1: Pinouts for RS-602/622 Computer Connector*

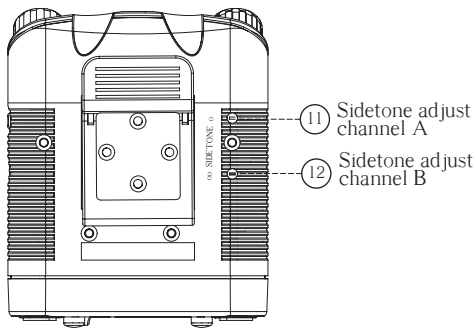

Figure 4: Sidetone controls for channels A and B

## 11 Sidetone Control, Channel A

## 12 Sidetone Control, Channel B

To adjust the beltpack's "sidetone," or the level of one's own voice in the headset, insert a small flat-headed screwdriver into one of the two holes labeled "sidetone" on the back of the beltpack, as shown in Figure 4.

The upper control adjusts the sidetone for channel A.  
The lower control adjusts the sidetone for channel B.

Turn the screwdriver until you can no longer hear any sidetone in the headset. This is called the “null” setting.

When you turn the screwdriver again, either clockwise or counterclockwise, the sidetone increases. Adjust the sidetone so that it is somewhere in the mid-range of possible settings, at a level that feels comfortable to you.

The need for an extreme sidetone setting to either limit could indicate a problem with the overall intercom system, such as lack of terminations or multiple terminations. A malfunctioning headset could also be the cause.

***Note:** The small raised dots next to the sidetone controls help you to identify the correct control in darkened environments. The channel A control has one raised dot adjacent to it. The channel B control has two raised dots adjacent to it.*

*Do not force the sidetone adjustment control past its stop points as this will damage it.*



# CONNECTING YOUR BELTPACK

You have the option to connect a beltpack to intercom stations, beltpacks, headsets, and a computer.

The following table shows the connectors for the RS-602 and RS-622 beltpacks, which vary slightly. Figure 5 illustrates the connectors for an RS-602 beltpack

<b>CONNECTOR</b>	<b>RS-602</b>	<b>RS-622</b>
Intercom	6-pin female	6-pin female
Loop-through	6-pin male	none
Auxiliary headset	2.5 mm	2.5 mm
Headset	4-pin male	6-pin female

*Table 1: Connectors for RS-602 and RS-622 Beltpacks*

## **① Intercom Connector**

The beltpack connects to a main station, power supply, or to other beltpacks through the connector labeled “intercom.” When you press the blue button next to this connector, the attached cable releases.

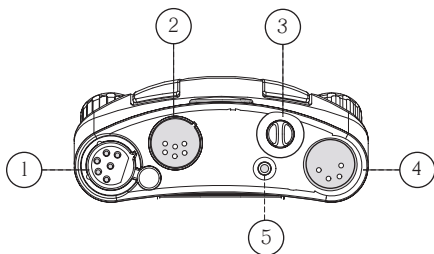

- 1 Intercom Connector
- 2 Loop-Through Connector
- 3 Program-Audio Volume Control
- 4 Auxiliary Headphone Connector
- 5 Headset Connector

---

Figure 1: RS-602 Connector Panel

**Note:** The beltpack's intercom connectors use the Switchcraft-style 6-pin configuration. If ordering Neutrik 6-pin plugs to make a cable or patch panel, specify that you need the Switchcraft pin configuration. This configuration usually has an "S" suffix at the end of the Neutrik model number.

<b>PIN</b>	<b>FUNCTION</b>
1	Ground
2	+ 30 VDC
3	Ch. B intercom
4	Ch. A intercom
5	Program input (+)
6	Program input (-)

*Table 2: Pinouts for RS-602/622 Intercom Connectors*

## ② Loop-Through Connector

The “loop-through” socket connects cable from the beltpack to a second beltpack (“looping through”). It can also connect the beltpack to an intercom station if necessary.

<b>PIN</b>	<b>FUNCTION</b>
1	Ground
2	+ 30 VDC
3	Ch. B intercom
4	Ch. A intercom
5	Program input (+)
6	Program input (-)

*Table 3: Pinouts for RS-602 Loop-Through Connector*

*Note: The RS-622 beltpack does not offer a loop-through connector.*

### **③ Program-Audio Volume Control**

Pins 5 and 6 of the beltpack's 6-pin intercom connector feed program audio into the headset. You can adjust the volume level of the program audio by rotating the program audio volume control. If necessary, you can mute the program audio by turning the knob all the way down.

With an RS-602 beltpack, you can “loop through” the program audio to additional beltpacks in a “daisy chain” configuration using the beltpack's “loop-through” connector. The program audio is transformer isolated and accepts line level signals in the  $-20$  to  $+10$  dBv range.

### **④ Auxiliary (“AUX”) Headphone**

Clear-Com designed the auxiliary headset connector, labeled “AUX,” for use with the CC-25 Ultra-Light headset. The beltpack's circuitry is designed to work with the CC-25 headset to produce excellent quality sound.

While certain types of mobile-phone style headsets will fit the 2.5 mm AUX jack, using these headsets degrades system performance due to reduced audio bandwidth and reduced noise rejection at the microphone. You can use such mobile-phone style headsets more reliably with listen-only applications.



The AUX connector provides bias voltage for electret microphones. With V-Pack, you can also program this connector for use with dynamic microphones.

*Note: Using multiple mobile-phone style headsets in a system could adversely affect nulling, crosstalk, and overall system performance.*

PIN	FUNCTION
Tip	Microphone
Ring	Earphone
Sleeve	Common

Table 4: Pinout for RS-602/622 AUX Headset Connector

## ⑤ Headset Connector

You connect a headset to the beltpack at the 4-pin (RS-602) or 6-pin (RS-622) male XLR connector labeled “headset.” The headset connector is always active and has priority if a second headset is connected to the auxiliary (“AUX”) connector. Generally you should connect only one headset at a time to a beltpack.

The RS-602 and RS-622 beltpacks provide power to an electret microphone. The microphone’s gain automatically adjusts to an electret microphone. See “Specifications” for impedance requirements.

<b>PIN</b>	<b>FUNCTION</b>
1	Mic (low)
2	Mic (high)
3	Headphone common
4	Ch. B headphone (high)
6	Ch. A headphone (high)
7	Headphone common

*Table 5: Pinout for RS-622 Headset Connector*

<b>PIN</b>	<b>FUNCTION</b>
1	Mic (low)
2	Mic (high)
3	Headphone (low)
4	Headphone (high)

*Table 6: Pinout for RS-602 Headset Connector*

# CUSTOMIZING YOUR BELTPACK

You can customize an RS-600 series beltpack for quick adaptation to the needs of any working environment. There are two methods for customizing your beltpack's settings:

- Using a beltpack's onboard controls
- Using the V-Pack programming software

This manual deals specifically with programming a beltpack with the onboard controls, and only briefly describes V-Pack. The V-Pack programming software has its own manual, which you can view and download at [www.clearcom.com](http://www.clearcom.com).

*Note: You may also refer to the printed guide on the back of the beltpack for quick instructions on setting up the beltpack with the onboard controls.*

## V-PACK SOFTWARE

The V-Pack programming software gives you access to the full range of options for customizing your beltpack. For example, you can program a call signal to appear as a steady or flashing light, a bright or dim light, or a tone. You can activate and adjust a noise gate. You can set a minimum headset level. -

A unique V-Pack feature is that you can create one custom setup and quickly transfer it to several beltpacks with the “beltpack cloning”

feature. This feature is useful for programming many beltacks with the same settings. And V-Pack includes many more features you can program for your beltack.

To operate the V-Pack software, you must first install it on a computer, then connect the VPC-1 cable to both a beltack and to your computer.

For more detailed instructions on using the software, see the V-Pack manual. You can access the manual from the Clear-Com Web site. A VPC-1 installation kit, which includes a factory CD containing the V-Pack software, a computer cable, and a printed V-Pack manual is available for purchase through your dealer or directly from Clear-Com.

## **ONBOARD PROGRAMMING**

With onboard programming, you customize the operation of your beltack using the controls on the beltack itself.

When you receive your beltack, it already contains the default settings that will meet the needs of most users. You do not need to program it unless you want to.

However, if you wish to change the settings to better meet your needs, you can do so with onboard programming. The beltack remembers your new settings until you change them again.

## SETTINGS YOU CAN CUSTOMIZE

Table 1 shows the beltpack functions you can customize with onboard controls. Note that each function is assigned a number, which you will refer to for programming.

<b>FUNCTION #</b>	<b>NAME</b>	<b>STATUS</b>	<b>CHANNELS</b>
Function 1	Mode Select	1,2,3,4	Both A and B
Function 2	Latch disable	on or off	A or B
Function 3	Talk disable	on or off	A or B
Function 4	Call-on-talk	on or off	A or B
Function 5	Electret mic (headset)	on or off	Both A and B
Function 6	Audible call (in earphone)	on or off	A or B
Function 7	Channel swap	on or off	Both A and B
Function 8	Channel exclusive	on or off	A or B
Function 9	Split-ear headset (RS-622)	on or off	Both A and B
Function A	Adjust Microphone Gain	variable	Both A and B
Function L	Locks out onboard access	on or off	Both A and B

*Table 1: Functions You Can Edit With Onboard Controls*

Before you program the beltpack with the onboard controls, the beltpack must be connected to an intercom line and receiving power, and must not be connected to a computer.

You can program most functions to operate on channel A, channel B, or both. However, some functions affect both channels. Table 1 shows how the functions affect channels.

## Mode Select, Function 1

A “mode” is one complete “package” of settings for a beltpack. Each beltpack’s memory holds four modes. You can easily select and activate any one of the four modes directly from the beltpack.

When you receive your beltpack, each of the four modes is preprogrammed with the Clear-Com default settings. Each mode is similar to the others, with only minor variations.

With onboard setup, you can select any one of the four modes and change specific settings to your requirements. Editing a mode’s settings automatically saves them in the beltpack’s nonvolatile memory.

### To select a mode:

1. Press and hold the setup button until the setup information window displays a “P” and then release the button.
2. Press and release the Talk A button. A winking number appears in the display. This is the currently selected mode.

*Note: A “winking” light flashes three times per second.*

3. To select a new mode, press the Talk A button to scroll through the four possible modes, 1 through 4.
4. When the desired mode appears in the display, press the setup button to select the mode and to exit setup.

The selected mode becomes the active mode for both beltpack channels. If you do not press a button within five seconds, the beltpack exits the setup program without making any changes.

## Latch Disable, Function 2

A beltpack's talk button normally latches when you tap it twice. If you select to disable this function, the talk button does not latch.

This setting is recommended if you use the call-on-talk feature, which causes the beltpack to send a call signal each time you press the talk button.

### To select “latch disable” for a channel:

1. Press and hold the setup button until the setup information window displays a “P” and then release the button.
2. Repeatedly press the Call A button until “2” appears in the display.
3. Press the appropriate channel's talk button (Talk A or Talk B) to toggle “latch disable” either on or off for that channel.
  - A channel's talk light reveals the function's status for that channel. If the talk light is on, “latch disable” is on; if the talk light is off, “latch disable” is off.
  - You can set latch disable for one or both channels.
4. When you have made your selections, press the setup button to save them and to exit setup, or press the Call A button to select other functions to program.

If you do not press a button within five seconds, the beltpack exits the setup program without making any changes.

## Talk Disable, Function 3

This function turns the talk button on or off. When disabled, the talk button does not function.

Set the talk button to off when you wish to operate the beltpack as a listen-only device.

### To select “talk disable” for a channel:

1. Press and hold the setup button until the setup information window displays a “P” and then release the button.
2. Repeatedly press the Call A button until “3” appears in the display.
3. Press the appropriate channel’s talk button (Talk A or Talk B) to toggle “talk disable” either on or off for that channel.
  - A channel’s talk light reveals the function’s status for that channel. If the talk light is on, “talk disable” is on for that channel; if the talk light is off, “talk disable” is off for that channel.
  - You can set talk disable for one or both channels.
4. When you have made your selections, press the setup button to save them and to exit setup, or press the Call A button to select other functions to program.

If you do not press a button within five seconds, the beltpack exits the setup program without making any changes.



## Call-on-Talk, Function 4

This function causes a beltpack to send a call signal each time you press or latch the talk button. You can toggle this function on or off.

When using “call-on-talk,” it is recommended that you set the talk button for non-latching operation. Call-on-talk is useful when operating call-signal based components such as the Clear-Com TW-40 2-way radio interface and the Clear-Com KB-212 speaker station.

### To select “call-on-talk” for a channel:

1. Press and hold the setup button until the setup information window displays a “P” and then release the button.
2. Repeatedly press the Call A button until “4” appears in the display.
3. Press the appropriate channel’s talk button (Talk A or Talk B) to toggle “call-on-talk” either on or off for that channel.
  - A channel’s talk light reveals the function’s status for that channel. If the talk light is on, “call-on-talk” is on for that channel; if the talk light is off, “call-on-talk” is off for that channel.
  - You can set call-on-talk for one or both channels.
4. When you have made your selections, press the setup button to save them and to exit setup, or press the Call A button to select other functions to program.

If you do not press a button within five seconds, the beltpack exits the setup program without making any changes.

## Electret Microphone, Function 5

This function allows a beltpack to operate with an electret-microphone equipped headset. It only affects a headset connected to the main headset jack. Toggling the function to off reverts the beltpack to dynamic microphone operation.

### To select “electret microphone” for a channel:

1. Press and hold the setup button until the setup information window displays a “P” and then release the button.
2. Repeatedly press the Call A button until “5” appears in the display.
3. Press the Talk A button to toggle “electret microphone” either on or off.
  - If the talk lights are on, the “electret microphone” option is on; if the talk light is off, the “electret microphone” option is off.
  - The “electret microphone” option affects both channels.
4. When you have made your selections, press the setup button to save them and to exit setup, or press the Call A button to select other functions to program.

If you do not press a button within five seconds, the beltpack exits the setup program without making any changes.

## **Audible Call Signal, Function 6**

When this function is on, the beltpack produces an audible call signal in the headset when a call signal is received. When this function is off, it does not.

The audible call signal's volume level is preset. (Volume may vary slightly, depending on headset.) This function is useful for unspoken cues when a visual call signal is not practical or effective.

### **To select an “audible call signal” for a channel:**

1. Press and hold the setup button until the setup information window displays a “P” and then release the button.
2. Repeatedly press the Call A button until “6” appears in the display.
3. Press the appropriate channel's talk button (Talk A or Talk B) to toggle “audible call signal” either on or off for that channel.
  - A channel's talk light reveals the function's status for that channel. If the talk light is on, “audible call signal” is on for that channel; if the talk light is off, “audible call signal” is off for that channel.
  - You can select “audible call signal” for one or both channels.
4. When you have made your selections, press the setup button to save them and to exit setup, or press the Call A button to select other functions to program.

If you do not press a button within five seconds, the beltpack exits the setup program without making any changes.

## Channel Swap, Function 7

When toggled to the “on” setting, this function reverses the beltpack’s audio channels so that channel A appears on channel B and channel B appears on channel A. Channel A’s controls operate channel B and channel B’s controls operate channel A.

Audio on pins 3 and 4 of the intercom channel are reversed to pins 4 and 3.

### To select “channel swap” for a channel:

1. Press and hold the setup button until the setup information window displays a “P” and then release the button.
2. Repeatedly press the Call A button until “7” appears in the display.
3. Press the Talk A button to toggle “channel swap” either on or off.
  - If both talk lights are on, “channel swap” is on; if both talk lights are off, “channel swap” is off.
  - The “channel swap” option affects both channels.
4. When you have made your selections, press the setup button to save them and to exit setup, or press the Call A button to select other functions to program.

If you do not press a button within five seconds, the beltpack exits the setup program without making any changes.

## Channel Exclusive, Function 8

This function causes the beltpack to operate with only one active channel. You select one of the beltpack's two channels to operate as the "exclusive" channel.

When you select an exclusive channel, the beltpack's two sets of talk and call buttons operate for only the selected channel. The selected channel's volume-control knob operates, while the beltpack's second volume-control knob does not operate.

### To select an "exclusive" channel:

1. Press and hold the setup button until the setup information window displays a "P" and then release the button.
2. Repeatedly press the Call A button until "8" appears in the display.
3. Press the appropriate channel's talk button (Talk A or Talk B) to toggle "channel exclusive" either on or off for that channel.
  - A channel's talk light reveals the function's status for that channel. If the talk light is on, "channel exclusive" is on for that channel; if the talk light is off, "channel exclusive" is off for that channel.
  - You can select either channel A or channel B to operate as the exclusive channel.
4. When you have made your selections, press the setup button to save them and to exit setup, or press the Call A button to select other functions to program.

If you do not press a button within five seconds, the beltpack exits the setup program without making any changes.

## **Split-ear Headset (RS-622 only), Function 9**

Normally, channel A audio goes to the right earphone of a headset and channel B audio goes to the left earphone.

When set to “on,” this function sends audio from both channels A and B to each earphone.

**Note:** This feature applies only to the RS-622 model.

### **To select “split-ear headset” for a channel:**

1. Press and hold the setup button until the setup information window displays a “P” and then release the button.
2. Repeatedly press the Call A button until “9” appears in the display.
3. Press the Talk A button to toggle “split-ear headset” either on or off.
  - A beltpack’s talk lights reveal the function’s status. If both talk lights are on, “split-ear headset” is on; if both talk lights are off, “split-ear headset” is off for that channel.
  - The split-ear headset option affects both channels.
4. When you have made your selections, press the setup button to save them and to exit setup, or press the Call A button to select other functions to program.

If you do not press a button within five seconds, the beltpack exits the setup program without making any changes.

## **Adjust Microphone Gain, Function A**

The microphone “gain” setting allows you to reduce the gain of the mic preamplifier by up to 12 dB. This feature affects both channels. You use the Channel A volume knob to adjust the microphone gain.

### **To adjust microphone gain:**

1. Connect the main or auxiliary headset to the beltpack, depending upon which mic gain you would like to adjust.
2. Press and hold the setup button until the setup information window displays a “P” and then release the button.
3. Repeatedly press the Call A button until “A” appears in the display. The talk light for channel A blinks to indicate that you use the channel A volume knob to adjust the gain.
4. Turn the channel A volume knob clockwise to increase the gain and counterclockwise to decrease it.

As you turn the knob, the setup information window displays a circular progress indicator. When the gain is set to its highest setting, the indicator lights up at the most clockwise position on the display. As you adjust the gain downwards, the progress indicator correspondingly moves counterclockwise on the display, until it is at its lowest setting. Turning the volume knob after the light has reached its highest or lowest setting will not further affect the gain.

5. Press the setup button to save the changes and exit the setup program or press the Call A button to select other functions to program.

The gain adjustment affects only the microphone of the currently connected headset. If you unplug this headset and connect the secondary headset (either main or auxiliary) the settings for that headset remain the same as previously programmed.

If you do not press a button within five seconds, the beltpack exits the setup program without making any changes.



## Lockout, Function L

“Lockout” allows you to prevent all editing of beltpack functions with onboard controls.

When you select “lockout,” you can access the on-off status of functions with the onboard controls, but you cannot edit them. You cannot access information which mode is active.

To regain access to editing, you can either restore the factory default settings from the beltpack itself, or use the V-Pack software.

### To select “lockout” for a channel:

1. Press and hold the setup button until the setup information window displays a “P” and then release the button.
2. Repeatedly press the Call A button until “L” appears in the display.
3. Press the Talk A button to toggle “lockout” either on or off.
  - The beltpack’s talk lights reveal the function’s status. If both talk lights are on, “lockout” is on; if both talk lights are off, “lockout” is off.
  - The lockout option affects both channels and all modes.
4. When you have made your selections, press the setup button to save them and to exit setup, or press the Call A button to select other functions to program.

If you do not press a button within five seconds, the beltpack exits the setup program without making any changes.

## RESTORING THE FACTORY DEFAULT SETTINGS

### **To restore the factory default settings for all four modes:**

1. Press and hold the setup button until the setup information window displays a “P” and then release the button.
2. Press and hold the Call A button. The display changes from “1” to “2.”
3. While still holding the call button down, press the setup button. The display momentarily shows an “F” to indicate that the beltpack is now programmed with the factory default settings.
4. Release the setup button and the call button.  
The beltpack resumes operation with the factory default settings.

# SPECIFICATIONS

0 dBv is referenced to 0.775 V RMS

## General

Amplifier Design: I.C. amplifiers, including solid-state digital switching and signaling circuits. Current-limited and short-circuit protected.

Signal to Noise: >75 dB

Bridging Impedance: >15k

Line Level: -14 dB, +5 dB max.

Sidetone Adjust: >35 dB

EMI and RFI rejection: >60 dB

## Microphone Pre-Amplifier

Headset Mic Impedance: 200 ohms

Gain, mic to line: 41 dB (dynamic)

Limiter Range: 26 dB

Frequency Response: 200 Hz – 12 kHz contoured for intelligibility

## Program Input

Program input	Balanced, transformer isolated
Input sensitivity:	-20 dBv to +10 dBv
Frequency response	50 Hz - 18 kHz, $\pm 2$ dB

## Headphone Amplifier

Load Impedance:	50 - 2,000 ohms
Output Level:	+17 dBv before clipping
Distortion:	<0.1% THD @ 1 kHz
Gain, line to output:	+34 dB
Frequency Response:	100 Hz - 18 kHz, $\pm 2$ dB

## Connectors

Intercom Line:	RS-602 (2) 6-pin XLR-M-F RS-622 (1) 6-pin XLR-F
----------------	--

Headset:	RS-602 4-pin XLR-M RS-622 6-pin XLR-M
----------	--

## Power Requirements

RS-602/622	55mA quiescent 62mA average talk, both channels simultaneously
------------	--

## **Power Requirements (continued)**

50mA talk with signaling, both channels  
simultaneously

DC Voltage Range: 12-32 volts

## **Environmental**

Operating Temp. Range: 0°C - 70°C (32°F - 158° F)

Humidity: 0 - 90% relative humidity

## **Dimensions**

4.58"H x 3.73"W x 1.34"D (116 x 95 x 34 mm)

## **Weight**

7.8 oz. (0.22 kg)

Specifications subject to change without notice.



# MAINTENANCE

## GENERAL USAGE NOTES

Cabling choices can greatly impact the performance of an intercom system. Length, gauge, and shield quality, as well as routing, must all be considered. For two-pair cable, crosstalk performance is affected both by length and DC resistance of the shield (the lower the better). The quality of the headset cable can affect crosstalk, particularly in large systems.

**Note:** For more information on installing a party-line system, see the *Party-Line Installation Manual*.

A beltpack's headphone amplifier accommodates impedances from 50 to 2000 ohms. The mic preamplifier accommodates impedances from 50 to 1000 ohms. Output level is more critical to optimal performance than the impedance. Higher impedances may require more microphone gain, thereby raising the noise floor.

## MAINTENANCE

### BELTCLIP

In some applications, you may want to wear the beltpack “upside down” or “sideways.”

To rotate the beltclip to a new position:

1. Remove the setup help label and the two retaining screws.
2. Rotate the beltclip 90° or 180° as desired.
3. Replace the screws.

The label on the beltclip is not reusable and must be replaced. You can order a replacement label from your distributor or from the factory.

Use the same procedure for replacing a broken or damaged beltclip.

## CLEANING

To clean the surface of your beltpack, use a damp cloth and mild soap. Remove all soap residue and excess moisture before returning to service.

## TROUBLESHOOTING

<b>PROBLEM</b>	Low audio level.
<b>CAUSE</b>	Multiple terminations on the line. Excessive capacitance and/or resistance due to cable length and/or gauge.
<b>SOLUTION</b>	If connected to more than one main station or power supply, check that there is only one termination per channel.



<b>PROBLEM</b>	Call light stays on.
<b>CAUSE</b>	DC voltage present on audio line pin 3.
<b>SOLUTION</b>	Check cables for shorts and cross-wiring. Make sure there is a termination on the channel.

<b>PROBLEM</b>	Mic level too low or too high.
<b>CAUSE</b>	Mic distance from mouth too far or too close; mic gain set incorrectly; sidetone set incorrectly; no terminations or more than one termination.
<b>SOLUTION</b>	Reposition mic and/or change headset mic gain.

<b>PROBLEM</b>	Headset level too low or too high.
<b>CAUSE</b>	Unterminated channel; improper impedance; shorted line.
<b>SOLUTION</b>	Adjust sidetone and volume controls; check wiring; use compatible headset.

<b>PROBLEM</b>	Can't change configuration on beltpack.
<b>CAUSE</b>	Disabled access to functions.
<b>SOLUTION</b>	Restore access by resetting to factory default settings or with V-Pack.

# WARRANTY

Vitec Group Communications (VGC) guarantees this product to be free of manufacturing defects in material and workmanship under normal use for a period of two years from the date of purchase.

## TECHNICAL SUPPORT

To ensure complete and timely support to its customers, VGC maintains Technical Service Centers (TSC) staffed by qualified technical personnel. A Technical Service Center is staffed to respond to all technical inquiries and to troubleshoot technical problems regarding all products supplied by VGC. A TSC is fully available to VGC's customers *during the full course of their warranty period.*

Instructions for reaching our Technical Service Centers are given below.

### **For technical support from Europe, the Middle East, and Africa**

Call: +49 40 66 88 40 40 Monday through Friday 09:00 – 17:00 (GMT)

+49 40 66 88 40 41 24hrs, any day (But you must have your PIN number ready.)

Web site: [www.clearcom.com](http://www.clearcom.com) (Click the 24 X 7 User Support symbol on the Web site.)

## **For technical support from the Americas and Asia**

Call: +1 510 496 6666 or 800 VITEC USA

Web site: [www.clearcom.com](http://www.clearcom.com) (Click the 24 X 7 User Support symbol on the Web site.)

Email: [support@clearcom.com](mailto:support@clearcom.com)

FAX: +1 510 496 6610

## **EXCEPTIONS**

This warranty does not include damage to a product resulting from cause other than part defect and malfunction. The VGC warranty does not cover any defect, malfunction, or failure caused beyond the control of VGC, including unreasonable or negligent operation, abuse, accident, failure to follow instructions in the manual, defective or improperly associated equipment, attempts at modification and repair not approved by VGC, and shipping damage. Products with their serial numbers removed or defaced are not covered by this warranty.

## **WARRANTY REPAIRS**

While VGC will ensure complete system integrity by providing whatever support is necessary to resolve any failure covered under the

terms of the warranty, the normal procedure will be to repair or replace any defective Line Replaceable Unit (LRU) that is returned to VGC during the warranty period.

A Line Replaceable Unit (LRU) is defined as: an assembly that can be safely removed from the system and readily replaced by plugging in a new unit. In the case of ancillary items such as power supplies, the entire power supply would be returned. Whereas, in the case of circuit cards, control panels, etc., only these assemblies would be returned for repair. All equipment provided by VGC is covered under the warranty.

This warranty does not include defects arising from installation (when not performed by VGC), lightning, power outages and fluctuations, air conditioning failure, improper integration with non-approved components, defects or failures of customer furnished components resulting in damage to VGC provided product.

## **NON-WARRANTY REPAIRS**

Equipment that is not under warranty must be sent prepaid to VGC. If requested, an estimate of repair costs will be issued prior to service. Once repair is approved and completed, the equipment will be shipped freight collect from the TSC.

## **REPLACEMENT UNITS**

Should VGC determine, in its reasonable discretion, that any part of a product is defective due to faulty materials or workmanship, VGC shall at its expense, repair or replace such part and return the repaired/replacement part to the customer. The provisions of this warranty shall apply to the repaired/replacement part for the unexpired portion, if any, of the warranty period.

## **EMERGENCY ON-SITE ASSISTANCE**

VGC can provide emergency on-site technical assistance in support of warranty activities. The level of support effort required will be decided on a case-by-case basis. VGC has the qualified technical staff to support any and all emergency site activities should they occur.

## **LIABILITY**

The foregoing warranty is VGC's sole and exclusive warranty. There are no other warranties (including without limitation warranties for consumables and other supplies), or guarantees, expressed or implied (including, without limitation, any warranties of merchantability or fitness for a particular purpose), of any nature whatsoever, whether arising in contract, tort, negligence of any degree, strict liability or otherwise, with respect to the products or any part thereof delivered hereunder and/or with respect to any non-conformance or defect in any such product and/or part thereof delivered hereunder and/or with

respect to any non-conformance or defect in any such product and/or part thereof delivered hereunder, or any other warranties or guarantees, including but not limited to any liability of VGC for any consequential and/or incidental damages and/or losses (including loss of use, revenue, and/or profits). In any event, the maximum extent of VGC's liability to customer hereunder shall not under any circumstances exceed the cost of repairing or replacing any part(s) found to be defective within the warranty period as aforesaid.

## **RETURNING EQUIPMENT FOR REPAIR**

All equipment returned for repair must be accompanied by:

- Documentation stating the return address, telephone number, date of purchase, and a description of the problem.
- A repair reference number.

To obtain a repair reference number, contact the appropriate Technical Service Center at the phone numbers or Web sites listed below. Our representatives will give you instructions and addresses for returning your equipment. By talking with our representatives, many problems can be resolved on the phone.

### **For returns from Europe, the Middle East, and Africa**

Call: +49 40 66 88 40 40 Monday through Friday 09:00 – 17:00 (GMT)

+49 40 66 88 40 41 anytime, any day

(But you must have your PIN number ready)

Web site: [www.clearcom.com](http://www.clearcom.com) (Click the 24 X 7 User Support symbol on the Web site.)

**For returns from the Americas and Asia**

Call: +1 510 496 6666 or 800 VITEC USA

Web site: [www.clearcom.com](http://www.clearcom.com) (Click the 24 X 7 User Support symbol on the Web site.)

Email: [support@clearcom.com](mailto:support@clearcom.com)

FAX: +1 510 496 6610