

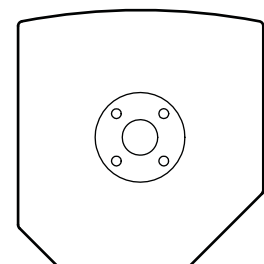

# EX10 User Guide

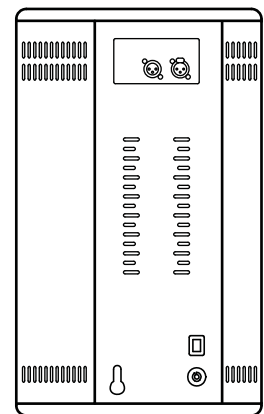
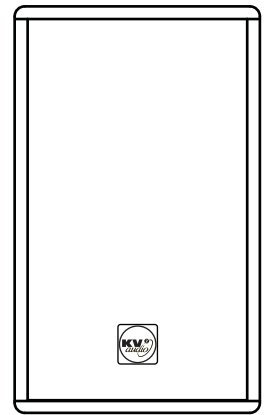
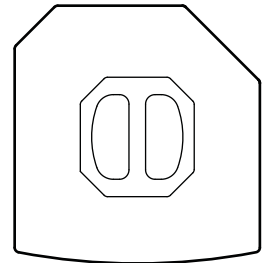

## The future of sound. Made perfectly clear.

At KV2 Audio our vision is to constantly develop technologies that eliminate distortion and loss of information providing a true dynamic representation of the source.

Our aim is to create audio products that absorb you, place you within the performance and deliver a listening experience beyond expectation.

# CONTENTS

<b>INTRODUCTION</b>	<b>3</b>
HOW TO USE THIS MANUAL	3
Icons used include:	3
Introducing the EX10	3
Electronics	3
Acoustic Components	4
Enclosure Design	4
APPLICATIONS	4
AC POWER	4
<b>CHAPTER 1: AC POWER REQUIREMENTS</b>	<b>5</b>
Voltage Requirements	5
The Power Connector	5
Current Requirements	5
AC Cable Color Coding	6
IMPORTANT SAFETY INSTRUCTIONS	6
SAFETY SUMMARY	6
The EX10 Control Panel	7
Audio Input and Output	7
<b>Chapter 2: AUDIO SIGNAL</b>	<b>7</b>
Amplifiers and Acoustic Filters	7
LED Status Lights	8
Power On / Limiter LED	8
Signal / Thermal LED	8
Stage Monitor Filter	8
<b>Chapter 3: ROTATING THE EX10 HORN</b>	<b>9</b>
<b>Appendix A: EX10 SPECIFICATIONS AND DATA</b>	<b>10</b>
<b>Appendix B: EX10 ACCESSORIES</b>	<b>11</b>
<b>EX10 DRAWING</b>	<b>11</b>

# INTRODUCTION

## HOW TO USE THIS MANUAL

As you read this manual, you'll find figures and diagrams to help you understand and visualize what you're reading. You'll also find numerous icons that serve as cues to flag important information or warn you against improper or potentially harmful activities.

### Icons used include:



**“NOTE”** identifies an important or useful piece of information relating to the topic under discussion.



**“TIP”** offers a helpful tip relevant to the topic at hand.



**“CAUTION”** gives notice that an action can have serious consequences and could cause harm to equipment or personnel, delays, or other problems.

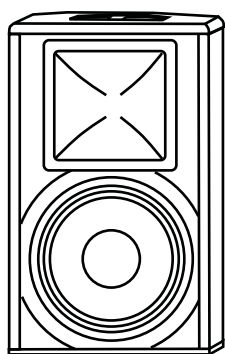

### Introducing the EX10

The EX10 is a 2-way high output, active, compact, full-range speaker system. Design objectives for the EX10 were focused on the expansion of KV2 Audio's primary philosophy of speakers systems with increased dynamic range, very high output and a consistent sound character no

matter what the output level. The EX10 sets new levels of performance for compact cabinets achieved through the integration of new amplifier, transducer and electronic control technologies that are closely tied to a passion for taking performance to the next level.

## Electronics

Amplifier power, electronic crossovers, phase alignment, equalization, time correction and speaker protection are integrated into the EX10's amplifier module. On-board electronics ensures fast, easy set up and complete control. An improved version of KV2 Audio's switch mode, current enhancing low frequency amplifier has been developed for the EX10. The new configuration improves overall system efficiency and increases output allowing passive radiation of heat to take place through a unique “fin-less” heat sink that can be placed in any position or direction. This ensures cool operation in horizontal or vertical applications. Additionally, the EX10 amplifier unit contains an internally located electric fan that is operated by a temperature sensing circuit which will slowly bring the fan online as required in extreme, high temperature situations.

Months of research were invested into designing circuitry that ensures that the extreme dynamic range exemplified by the speaker system is maintained even under clipping conditions. The real test of the EX10's limits is when it is exposed to the rigors and demands of live audio playback where consistent clipping of amplifiers, generation of distortion artifacts, dramatic increases in the floor and the elimination of dynamic range put the product to an extreme test.

The EX10's high frequency compression driver is powered and controlled by KV2 Audio's standard low intermodulation distortion, Class A/B, push-pull, high and mid frequency amplifier design. Metal Oxide Silicon Field Effect Transistors (MOSFET) are used for the output stage and the compression driver coupled through a transformer balanced speaker output. The entire performance strategy for this type of design is based on producing the lowest intermodulation distortion possible and the highest audio quality in the critical mid and high operating bands.

## Acoustic Components

KV2 Audio has developed a revolutionary woofer technology called Trans-Coil™. The woofer has two coils, a standard voice coil assembly and a second coil placed directly on the neodymium magnetic circuit's pole piece. This technology eliminates voice coil inductance resulting in a flat impedance response above the resonance point and achieves faster transient response through increased force and control of the moving mass. It also linearises acoustic and electrical phase response, reduces harmonic distortion and increases power transfer and transducer speed. Through this technology, the speaker now behaves like both a woofer at lower frequencies and like a mid-range at higher frequencies allowing a seamless transition to take place at the crossover frequency.

The EX10's patent pending neodymium compression driver is loaded on a constant directivity horn designed for smooth, wide dispersion performance. More importantly, it has also been designed to precisely match the power response of the woofer at the crossover frequency, a crucial design objective that ensures smooth transition and minimizes anomalies.

The compression driver is a new, patent pending 1.75-inch titanium diaphragm design, featuring a complex geometry phase plug that dramatically lowers distortion, eliminates ring modes and provides clearer, ripple free performance.

The EX10 horn was designed with two primary performance goals. The mechanical design allows the horn to be rotated 90 degrees, allowing for complete flexibility in selection of vertical and horizontal system set up. The horn design is based on constant-directivity geometry with an emphasis on generating very low air distortion artifacts, maintaining low transducer compression ratios, high output and wide dispersion (100 x 80). The horn is an injected molded aluminum part that functions as a heat dissipater for the compression driver's neodymium magnetic motor structure.

## Enclosure Design

The EX10 is a very compact, asymmetrical geometry enclosure design allowing it to be used in a variety of applications and featuring a number of ergonomically designed components that make it lightweight and easy to use. An extensive set of professional hardware features enables the EX10 to be used in a variety of environments using an array of industry standard hardware. These facilitate both portable and fixed installations

with a maximum amount of mounting flexibility.

A specially molded aluminum top handle was designed and fitted to the top of the cabinet. It functions as the principle pick up handle as well as providing several fixed installation and hanging solutions. It has a centrally located M10 hang point as well as four additional M6 bracket points. The handles four principal mounting bolts also provide an Omnimount™ bracket point. There are two side-mounted M10 hang points that can be used with brackets or eyebolts.

## APPLICATIONS

- Live and Playback Applications
- Portable PA Systems
- Floor Monitoring Applications
- Corporate Events
- Fixed Installations

The EX 10 is an advanced self-powered loudspeaker system with on-board amplification and control systems. Understanding power distribution, voltage and current requirements, as well as electrical safety issues, is critical to the safe operation of the EX10.

## AC POWER

The EX10 uses a PowerCon 3-pole AC main system with locking connectors to prevent accidental disconnection. The main AC connector (blue) serves as the power input.

The EX10 operates in either 115V, 230V or 250V modes. Although pre-configured at the factory, the unit's operating voltage mode can be changed in the field.

# CHAPTER 1: AC POWER REQUIREMENTS

## Voltage Requirements

The EX10 operates safely and without audio discontinuity if the AC voltage stays within the operating window of 100V-120V in 115V mode, 205V-240V in 230V mode and 225V-260V when working in 250V mode, at 50 or 60Hz.



**CAUTION:** If the On LED does not illuminate or the system does not respond to audio input, remove AC power immediately. Verify that the voltage is within the proper range. If the problem persists, please contact KV2 Audio or an authorized service center.

If the voltage drops below the low boundary of its safe operating range, the loudspeaker will shut down if the voltage does not rise above the low boundary before storage circuits are depleted. How long the loudspeaker will continue to function during brownout depends on the amount of voltage drop and the audio source level during the drop.

If the voltage increases above the upper boundary of the range, the power supply can be damaged.



**NOTE:** It is recommended that the voltage supply be within the rated voltage window. This ensures that AC voltage variations from the service entry—or peak voltage drops due to cable runs—do not cause the amplifier to cycle on and off or cause damage to the power supply.



**NOTE:** For best performance, the AC cable voltage drop should not exceed 10 volts, or 10 percent at 115 volts and 5 percent at 230 volts.

Make sure that even with the AC voltage drop, the AC voltage always stays within recommended operating ranges. The minimum electrical service amperage required by a EX10 speaker system is the sum of each loudspeaker's maximum continuous rms current. An additional 50 percent above the minimum amperage is recommended to prevent peak voltage drops at the service entry.

**The Power Connector** The EX10 requires a grounded outlet. It is very important that the loudspeaker AC supply be properly grounded in order to operate safely and properly. Use the PowerCon AC cable-wiring diagram on page 5 to create international or special-purpose power connectors:

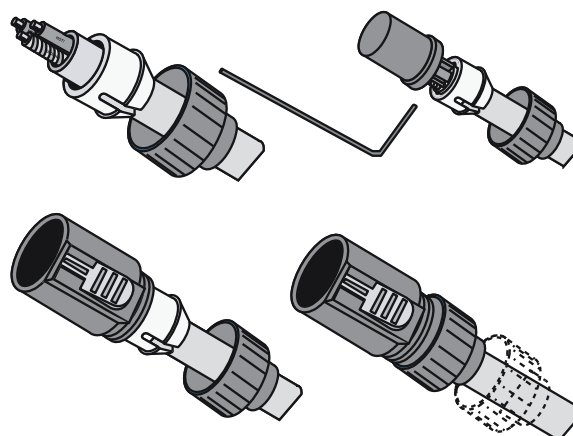

Power connector assembly

## Current Requirements

Each EX10 requires approximately 5 Amps max at 115V AC for proper operation. This allows up to three EX10's to be powered from one 15 A breaker at 115V and up to 6 loudspeakers at 230V or 250V.

The EX10 presents a dynamic load to the AC mains, which causes the amount of current to fluctuate depending on quiet or loud operating levels. Since different cables and circuit breakers heat up at varying rates, it is essential to understand the types of current ratings and how they correspond to circuit breaker and cable specifications.

The maximum long-term continuous current is the maximum rms current during a period of at least ten seconds. It is used to calculate the temperature rise in cables, in order to select a cable size and gauge that conforms to electrical code standards. It is also used to select the rating for slow-reacting thermal breakers.

The burst current is the maximum rms current during a period of approximately one second, used to select the rating of most magnetic breakers and to calculate the peak voltage drop in long AC cables according to the formula:  $V_{pk}(\text{drop}) = I_{pk} \times R(\text{cable total})$

The ultimate short-term peak current is used to select the rating of fast reacting magnetic breakers. Use the table below as a guide when selecting cable gauge size and circuit breaker ratings for your operating voltage.

Current Draw	115V Mode	230V, 250V
Max Long Term Continuous	5 A rms	2.5 A rms
Burst Current	7.5 A rms	5 A rms
Short Term Peak	20 A peak	10 A peak

## AC Cable Color Coding

If the colors referred to in the diagram don't correspond to the terminals in your plug, use the following guidelines: Connect the blue wire to the terminal marked with a N or colored black. Connect the brown wire to the terminal marked with an L or colored red. Connect the green and yellow wire to the terminal marked with an E or colored green or green and yellow.

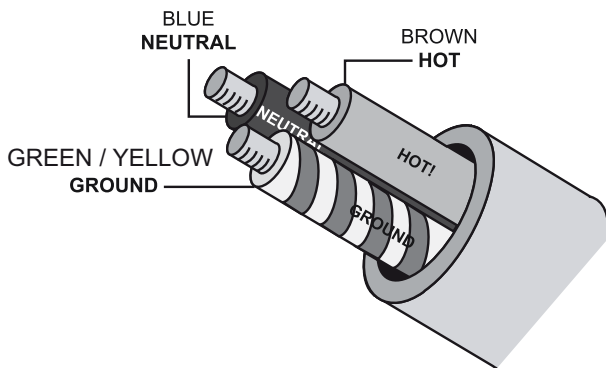

*Power cable color coding*



**CAUTION:** The EX10 requires a ground connection. Always use a grounded outlet and plug.

## IMPORTANT SAFETY INSTRUCTIONS

- 1 Read all product instructions.
2. Keep printed instructions, do not throw away.
3. Respect and review all warnings.
4. Follow all instructions.
5. Do not use this loudspeaker near water, in unprotected outdoor areas or in rain or wet conditions.
6. Clean only with dry cloth.
7. Do not block any ventilation openings.
8. Install in accordance with KV2 Audio recommended installation instructions.
9. Do not install near any heat sources such as heat radiators, heat registers, stoves, or other apparatus that produce heat.
10. Do not defeat the safety purpose of the grounding type plug. A grounding type plug has two blades and a third grounding connector. The third connector is provided for your safety. If the provided plug does not fit

into your outlet, consult an electrician for replacement of the obsolete outlet.

11. Protect the power cord from being walked on or pinched, particularly at plugs, convenience receptacles, and the point where they exit from the loudspeaker. The AC mains plug or appliance coupler shall remain readily accessible for operation.
12. Only use accessories specified by KV2 Audio.
13. Install the product only with rigging specified by KV2 Audio, or sold with the loudspeaker.



**CAUTION:** Rigging should only be done by experienced professionals.

14. Unplug this loudspeaker during lightning storms or when unused for long periods of time.
15. Refer all servicing to qualified service personnel. Servicing is required when the loudspeaker has been damaged in any way, such as when the power-supply cord or plug has been damaged; liquid has been spilled or objects have fallen into the loudspeaker; rain or moisture has entered the loudspeaker; the loudspeaker has been dropped; or when for undetermined reasons the loudspeaker does not operate normally.

## SAFETY SUMMARY

To reduce the risk of electric shock, disconnect the loudspeaker from the AC mains before installing audio cable. Reconnect the power cord only after making all signal connections. Connect the loudspeaker to a two-pole, three-wire grounding mains receptacle. The receptacle must be connected to a fuse or circuit breaker. Connection to any other type of receptacle poses a shock hazard and may violate local electrical codes. Do not allow water or any foreign object to get inside the loudspeaker. Do not put objects containing liquid on or near the unit. To reduce the risk of overheating the loudspeaker, avoid exposing it to direct sunlight. Do not install the unit near heat-emitting appliances, such as a room heater or stove. This loudspeaker contains potentially hazardous voltages. Do not attempt to disassemble the unit. The unit contains no user serviceable parts, repairs should be performed only by factory trained service personnel.

## CHAPTER 2: AUDIO SIGNAL

### The EX10 Control Panel

The EX10 features an easy to use rear control panel featuring audio input and output, level control, LED status lights and a low pass filter that can be engaged when the loudspeaker is used as a stage monitoring device.

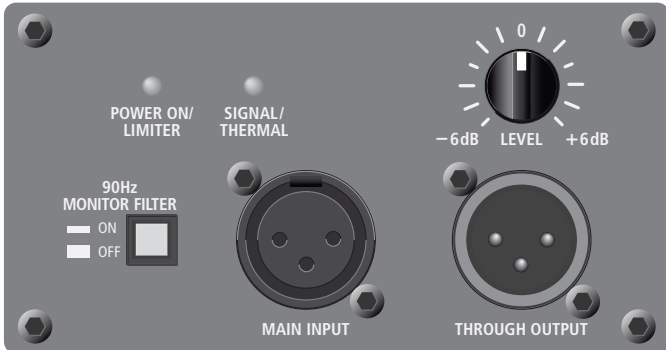

EX10 Rear panel

### Audio Input and Output

The EX10 uses a balanced, female XLR connector for the audio input connector, and a male XLR connector to provide through output signal. The through output connector, wired in parallel to the audio input, will continue to provide the input signal if the EX10 is turned off. The audio input circuit presents a 20 kOhm balanced input impedance to a three-pin XLR connector with the following connectors:



Main input

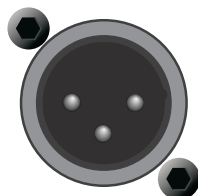

Through output

Pin 1 - Ground

Pin 2 - Signal (+)

Pin 3 - Signal (-)

Case - Earth (AC) ground and chassis

Audio signal can be daisy-chained using the through output connector on the input panel. A single source can drive multiple EX10 speakers with a paralleled input loop. If you are driving multiple EX10's in an array, make certain that the source device can drive the total load impedance presented by the paralleled input circuit of the array.

The audio source must be capable of producing a minimum of 20 dB volts (10 volts rms into 600 ohms) to produce the maximum peak SPL over the operating bandwidth of the loudspeaker. To avoid distortion from the source, make sure the source equipment provides an adequate drive circuit design for the total paralleled load impedance presented by the array. The input impedance for a single loudspeaker is 20 kOhms. If "n" represents the number of EX10 loudspeakers in a system, paralleling the inputs of n loudspeakers will produce a balanced input load of 20 kOhms divided by "n".



**NOTE:** Most source equipment is safe for driving loads no smaller than 10 times the source's output impedance. For example, cascading an array of 10 units consisting of EX10 speakers produces an input impedance of 2000 ohms (20kOhms divided by 10). The source equipment should have an output impedance of 200 Ohms or less. This is also true when connecting EX10's in parallel (loop out) with other KV2 Audio amplifiers and active speakers and subwoofers.



**TIP:** If the loudspeaker produces noises such as hiss and popping, disconnect the audio cable from the loudspeaker, if the noise stops, then most likely the problem is not with the loudspeaker. Check the audio cable, source, and AC power for the source of the problem.



**NOTE:** Ensure that all cabling carrying signal to multiple amplifiers and active speaker systems is wired correctly. Make sure that the polarity has not been reversed. Reversed polarity can cause severe degradation in frequency response and can also impact the dispersion characteristics of the speaker.

### Amplifiers and Acoustic Filters

The EX10 is powered by two separate power amplifiers specifically designed and optimized for the low frequency and high frequency drivers. The control system in the EX10 processes the audio signal through a series of electronic filters and circuits providing equalization, crossover filters, phase adjustment, thermal and overdrive protection.

The EX10 employs a protection system based on rms limiting of the amplifiers. This type of protection strategy allows the speaker to operate safely under overload conditions. When the rms "limiter" engages, the output level of both amplifiers is reduced to a safe

operating level. This type of protection allows the phase response of the system to remain unchanged as the level is lowered. By not compressing or limiting peak signal, dynamics also remain unchanged. The control objective is to regulate the operating temperature of the transducers magnetic circuits log term. This ensures no impact on performance due to power compression and allows the components to retain their ability to reproduce high dynamics.

## LED Status Lights

The EX10 control panel uses two distinct LED's to provide operating status information.

### Power On / Limiter LED

This LED turns green when the speaker is turned ON. The light will continue to be green during normal operation of the speaker system. Should the rms limiting system be engaged due to overdriving of the EX10, the LED will change color from green to yellow. The audible effect of the rms limiter is a lowering of overall output level. The rms limiter will disengage only if the input level is turned down.

### Signal / Thermal LED

This LED turns green when there is audio signal present in the EX10. This signal indicator can be used to troubleshoot wiring problems. The LED will change from green to yellow under a thermal condition resulting from overheating of the amplifier system. Under this condition, the speaker system will shut down. You can expect for the system to be down for at least 2-3 minutes depending the ambient temperature and whether the system is being exposed to direct sun light.

**NOTE:** The EX10 features a finless heatsink that allows it to operate in any position. There is also an internal fan located inside the amplifier module. The fan speed is dependent on two factors; the temperature of the heat sink and the output level of the speaker. As temperature increases, so does fan speed. As audio level increases, fan speed also increases as a preventative measure designed to keep the heat sink temperature low. Under normal operating conditions, the fan noise remains inaudible. Please contact KV2 Audio or a local service representative should the system enter a thermal condition under normal operating conditions.

## Stage Monitor Filter

The EX10 features a 90 Hz Monitor Filter control. Depressing the button engages a low pass audio filter allowing the speaker to be effectively used to reproduce frequencies above 90Hz.

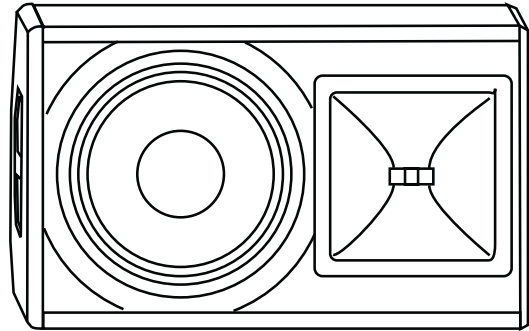

**NOTE:** When using EX10 as a stage monitor, the horn should be rotated 90°, please see page 9 for instructions.



## CHAPTER 3: ROTATING THE EX10 HORN

The EX10 horn can be rotated ninety degrees in order to accommodate applications where the speaker will be used or installed horizontally.

This can be accomplished by removing the front grill.

Removing the horn, rotating and replacing the horn.

Replacing the front grille.

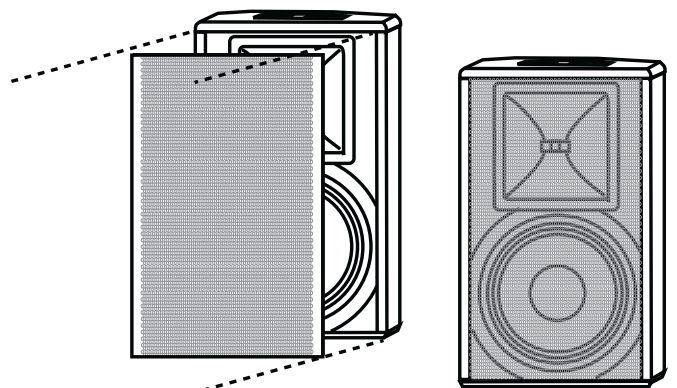
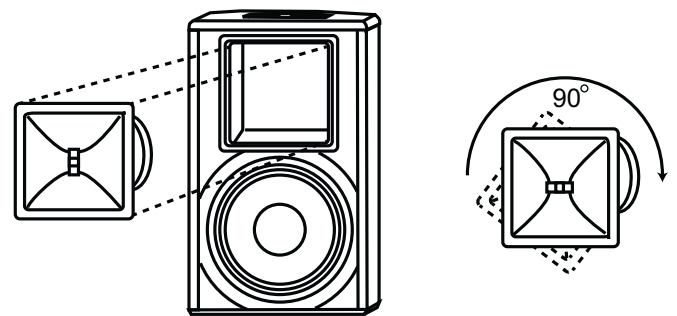
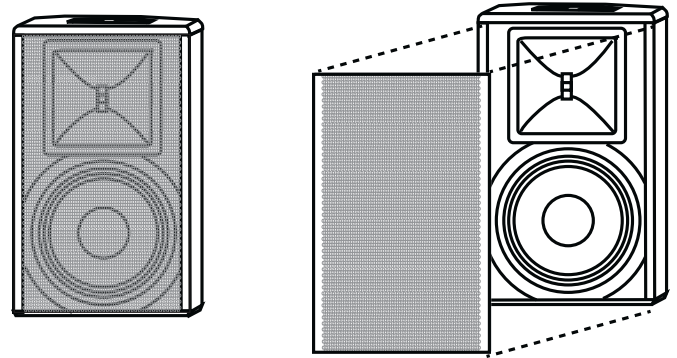

## APPENDIX A: EX10 SPECIFICATIONS AND DATA

### System Acoustic Performance

Max SPL Long-term	126dB
Max SPL Peak	129dB
-3dB Response	65Hz - 20kHz
-10dB Response	55Hz - 28kHz
Crossover Point	1.6kHz

### High Frequency Section

Acoustic Design	Horn Loaded
High Horn Coverage Horizontal / Vertical	100° x 80°
Rotatable Horn	YES
Throat Exit Diameter / Diaphragm Size	1" / 1.75"
Diaphragm Material	Nitride Titanium
Magnet Type	Neodymium

### High Frequency Amplifier Specification

Type	Class AB Push-Pull
Rated Continuous Power	50W
Distortion	<0.05%
Operating Bandwidth	1.6kHz - 28kHz

### Low Frequency Section

Acoustic Design	Front Loaded, Bass Reflex
Woofer Size / Voice Coil Diameter / Design	10" / 2.5" / Trans Coil
Magnet Type	Neodymium
Diaphragm Material	Epoxy Reinforced Cellulose

### Low Frequency Amplifier Specification

Type	High efficiency, Current-enhancing switch mode
Rated Continuous Power	450W
Distortion	<0.05%
Operating Bandwidth	55Hz - 1.6kHz

### Signal Input

Input Sensitivity	1.0V RMS
Input Impedance	20 kΩ

### Power Requirements

Power Connector	Neutrik PowerCon®
Operating Voltage	100-120V@60Hz   205-240V@50Hz   225-260V@50Hz
Recommended Amperage	6A 115V   3A 230V   3A 250V

### Cabinet





Cabinet Material	Baltic birch
Handles	1
Pole Mount	35mm
Color	"Orange peeled" Matt Black or any RAL

### Physical Dimensions

Height	514mm (20.23")
Width	310mm (12.20")
Depth	325mm (12.79")
Weight	22kg (48.4lbs)

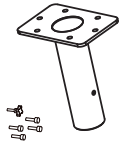
# APPENDIX B: EX10 ACCESSORIES, DRAWING

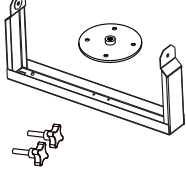
## EX10 ACCESSORIES

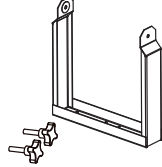
<p><b>Heavy duty cover for EX10</b> part name: COVER EX10 part number: KVV 987 068</p>		<p><b>Top Hat Adapter for EX Brackets</b> part name: Top Hat Adapter part number: KVV 987 090 - including connection bolts</p>	
<p><b>Heavy duty telescopic speaker pole for ES/EX series</b> part name: KV2-H part number: KVV 987 130 - M20</p>		<p><b>Horizontal bracket for EX10</b> part name: EX10 Horizontal Bracket part number: KVV 987 036 - including top hat cover adaptor plate and two connection bolts</p>	
<p><b>Telescopic speaker pole for ES/EX series</b> part name: KV2-L part number: KVV 987 041 - 35mm</p>		<p><b>Vertical bracket for EX10</b> part name: EX10 Vertical Bracket part number: KVV 987 033 - including two connection bolts</p>	

## EX10 DRAWING

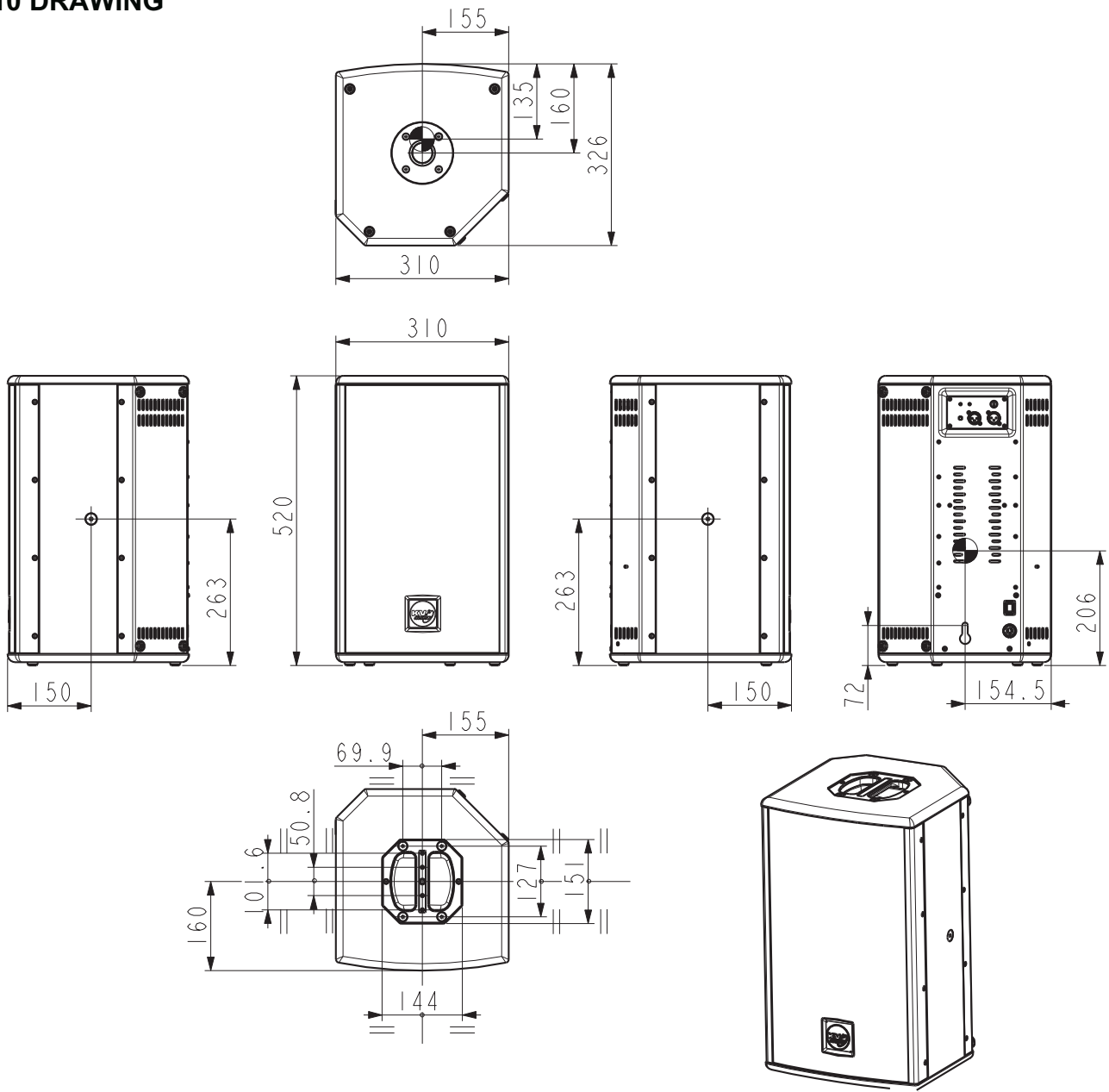

# The future of sound. Made perfectly clear.

At KV2 Audio our vision is to constantly develop technologies that eliminate distortion and loss of information providing a true dynamic representation of the source.

Our aim is to create audio products that absorb you, place you within the performance and deliver a listening experience beyond expectation.



KV2 Audio, Nádražní 936, 399 01 Milevsko, Czech Republic  
Tel. +44(0)1423 816868  
[www.kv2audio.com](http://www.kv2audio.com)