

# eW 300 G2

Instructions for use

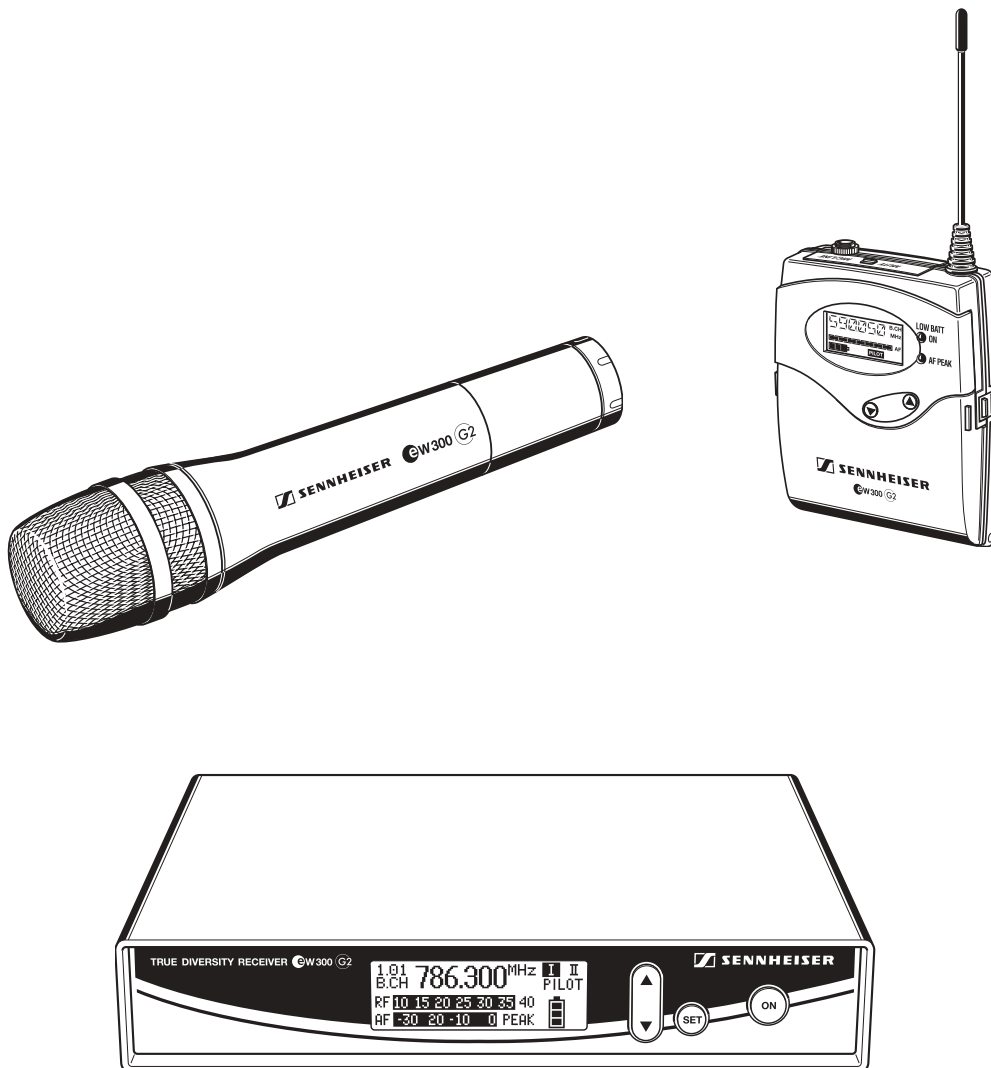

## **Thank you for choosing Sennheiser!**

We have designed this product to give you reliable operation over many years. Over sixty years of accumulated expertise in the design and manufacture of high-quality electro-acoustic equipment have made Sennheiser a world-leading company in this field.

Please take a few moments to read these instructions carefully, as we want you to enjoy your new Sennheiser products quickly and to the fullest.

# Contents

The evolution wireless series ew 300 G2 .....	50
The channel bank system .....	50
Safety instructions .....	51
System variants .....	51
Overview of operating controls .....	52
EM 300 G2 rack-mount receiver .....	52
SK 300 G2 bodypack transmitter .....	53
SKM 300 G2 radiomicrophone .....	54
Indications and displays on the receiver .....	55
Indications and displays on the transmitters .....	56
Preparing the components for use .....	58
EM 300 G2 rack-mount receiver .....	58
SK 300 G2 bodypack transmitter .....	61
SKM 300 G2 radiomicrophone .....	63
Using the components .....	64
Switching the components on/off .....	64
Muting the transmitters .....	65
Activating/deactivating the lock mode .....	65
The operating menu .....	66
The buttons .....	66
Overview of menus .....	66
Working with the operating menu .....	67
Operating menu of the receiver .....	69
Operating menu of the transmitters .....	72
Adjustment tips for the operating menu .....	74
Switching between channel banks .....	74
Switching between the channels in a channel bank .....	74
Selecting the frequencies to be stored in the channel bank "U" .....	74
Scanning the channel banks for free channels (EM 300 G2 only) .....	75
Multi-channel operation .....	76
Adjusting the sensitivity (transmitters only) .....	76
Adjusting the audio output level (EM 300 G2 only) .....	77
Adjusting the squelch threshold (EM 300 G2 only) .....	77
Selecting the standard display .....	78
Entering a name .....	79
Loading the factory-preset default settings .....	79
Activating/deactivating the pilot tone transmission or pilot tone evaluation ..	79
Activating/deactivating the lock mode .....	80
Adjusting the contrast of the graphic display (EM 300 G2 only) .....	80
Exiting the operating menu .....	80
If problems occur... ..	81
Error checklist .....	81
Recommendations and tips .....	82
Care and maintenance .....	83
Additional information .....	84
HDX noise reduction .....	84
Wireless transmission systems .....	84
Squelch .....	85
Diversity reception .....	85
Specifications .....	86
Connector assignment .....	87
Polar diagrams and frequency response curves of microphones/microphone heads .....	88
Accessories .....	89

# The evolution wireless series ew 300 G2

With the evolution wireless series ew 300 G2, Sennheiser offers musicians, video and sound amateurs high-quality state-of-the-art RF transmission systems with a high level of operational reliability and ease of use. Transmitters and receivers permit wireless transmission with studio-quality sound. The excellent transmission reliability of the ew 300 G2 series is based on the use of

- further optimized PLL synthesizer and microprocessor technology,
- the **HDX** noise reduction system,
- the pilot tone squelch control,
- the true diversity technology (rack-mount receiver only),
- and the scan function for scanning the channel banks for free channels.

## The channel bank system

The ew 300 G2 systems are available in five UHF frequency ranges with 1440 transmission/receiving frequencies per frequency range. Please note: Frequency usage is different for each country. Your Sennheiser agent will have all the necessary details on the available legal frequencies for your area.

Range A: 518 to 554 MHz  
Range B: 626 to 662 MHz  
Range C: 740 to 776 MHz  
Range D: 786 to 822 MHz  
Range E: 830 to 866 MHz

Transmitters and receivers have nine channel banks with eight switchable channels each.

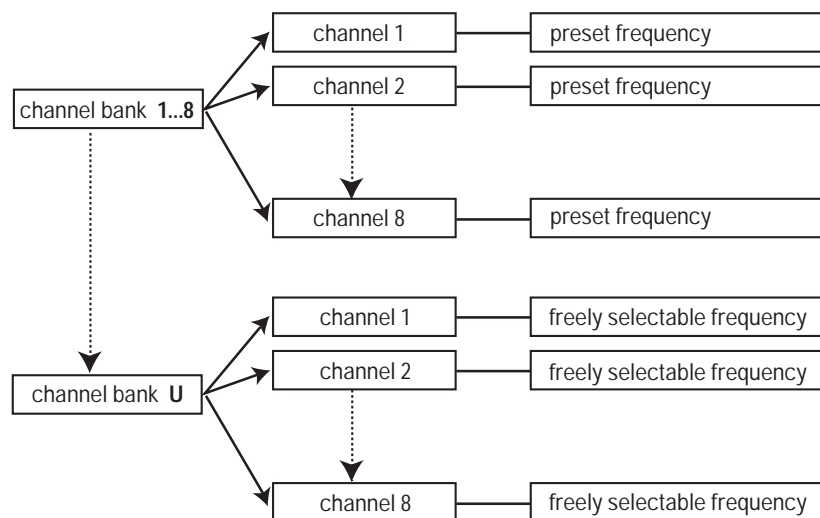

The channel banks "1" to "8" have eight switchable channels that are factory-preset to a transmission/receiving frequency (see enclosed frequency table). These transmission/receiving frequencies cannot be changed but have been preset so that e.g. country-specific regulations on frequency usage are taken into account. The channel bank "U" (user bank) has eight switchable channels to store your selection out of 1440 transmission/receiving frequencies that are freely selectable within the preset frequency range.

An advantage of the factory-preset frequencies is that

- the systems are ready for immediate use after switch-on,
- several systems can be operated simultaneously on the preset channels without causing intermodulation interference.

# Safety instructions

Never open electronic units! If units are opened by customers in breach of this instruction, the warranty becomes null and void.

Keep the units away from central heating radiators and electric heaters. Never expose them to direct sunlight.

Use the units in dry rooms only.

Use a damp cloth for cleaning the units. Do not use any cleansing agents or solvents.

## System variants

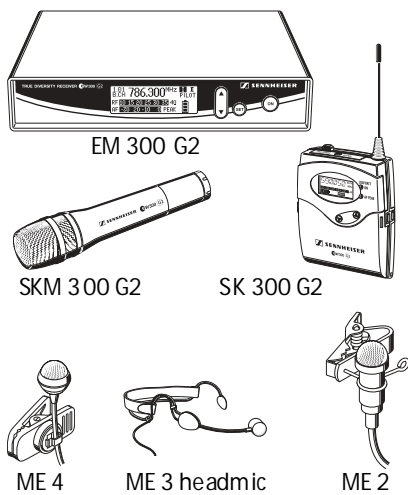

### Areas of application

System	Areas of application
ew 312 ©2	Theater, presentation (omni-directional)
ew 322 ©2	Theater, presentation (high feedback rejection)
ew 352 ©2	Sports (aerobic), vocals
ew 372 ©2	Instruments
ew 335 ©2	Speech, vocals
ew 345 ©2	Vocals (high feedback rejection)
ew 365 ©2	Vocals, presentation (high feedback rejection)

### Delivery includes

System	EM 300 G2	SK 300 G2	SKM 300 G2 with MD 835 mic head (dynamic, cardioid)	SKM 300 G2 with MD 845 mic head (dynamic, super-cardioid)	SKM 300 G2 with ME 865 mic head (condenser, super-cardioid)	ME 2 clip-on microphone (condenser, omni)	ME 3 headset (condenser, super-cardioid)	ME 4 clip-on microphone (condenser, cardioid)	NT 2-1 mains unit	2 batteries	2 telescopic antennas	Microphone clamp	Instrument cable	Instructions for use
ew 312 ©2	X	X				X			X	X	X			X
ew 322 ©2	X	X						X	X	X	X			X
ew 352 ©2	X	X					X		x	X	X			X
ew 372 ©2	X	X							X	X	X		X	X
ew 335 ©2	X		X						X	X	X	X		X
ew 345 ©2	X			X					X	X	X	X		X
ew 365 ©2	X				X				X	X	X	X		X

# Overview of operating controls

## EM 300 G2 rack-mount receiver

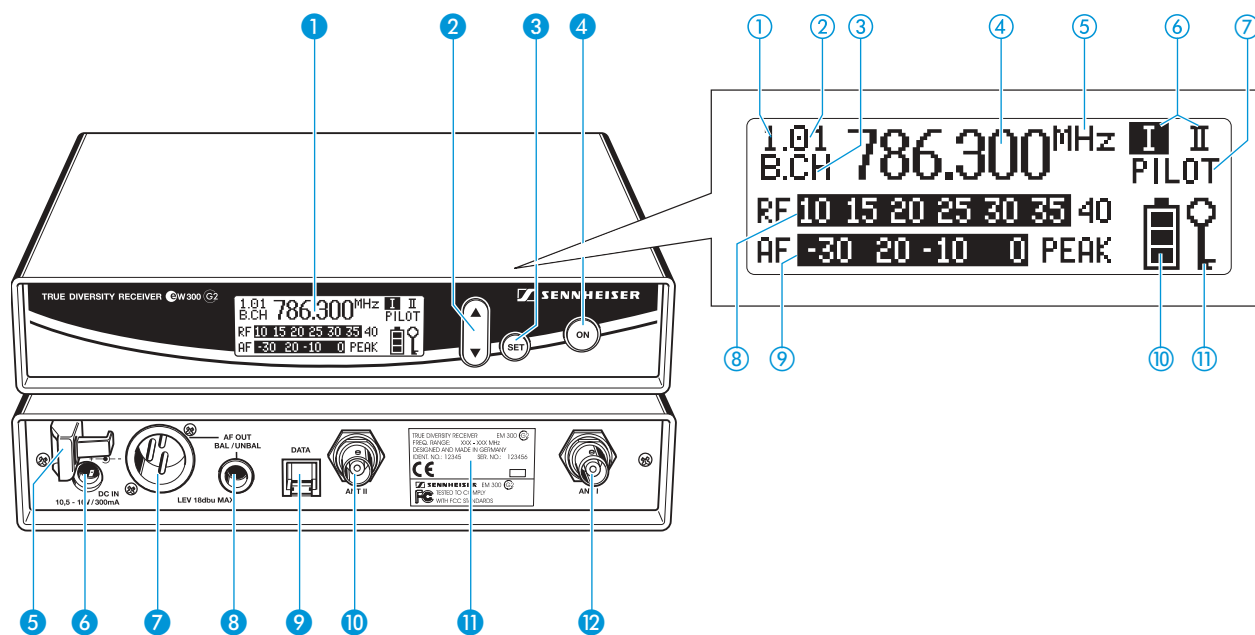

### Operating controls

- 1 Graphic display, backlit
- 2 ▼/▲ rocker button (DOWN/UP), backlit
- 3 SET button, backlit
- 4 ON button, backlit (serves as the ESC (cancel) key in the operating menu)
- 5 Cable grip for power supply DC cable
- 6 DC socket for connection of mains unit (DC IN)
- 7 Audio output (AF OUT BAL), XLR-3M socket, balanced
- 8 Audio output (AF OUT UNBAL), ¼" (6.3 mm) jack socket, unbalanced
- 9 Service interface (DATA)
- 10 Antenna input II (ANT II), BNC socket
- 11 Type plate
- 12 Antenna input I (ANT I), BNC socket

### Graphic display panel

- 1 Display for the current channel bank "1...8, U"
- 2 Display for the current channel number "1...8"
- 3 "B.CH" – abbreviation for channel Bank and Channel number
- 4 Alphanumeric display
- 5 "MHz" – appears when the frequency is displayed
- 6 Diversity display (antenna I or antenna II active)
- 7 "PILOT" display (pilot tone evaluation is activated)
- 8 Level display for received RF signal "RF"
- 9 Level display for received audio signal "AF", with "PEAK" warning
- 10 4-step transmitter battery status display
- 11 Lock mode icon (lock mode is activated)

#### Note:

For further illustrations and examples of the different standard displays, please refer to the section "Selecting the standard display" on page 78.

## SK 300 G2 bodypack transmitter

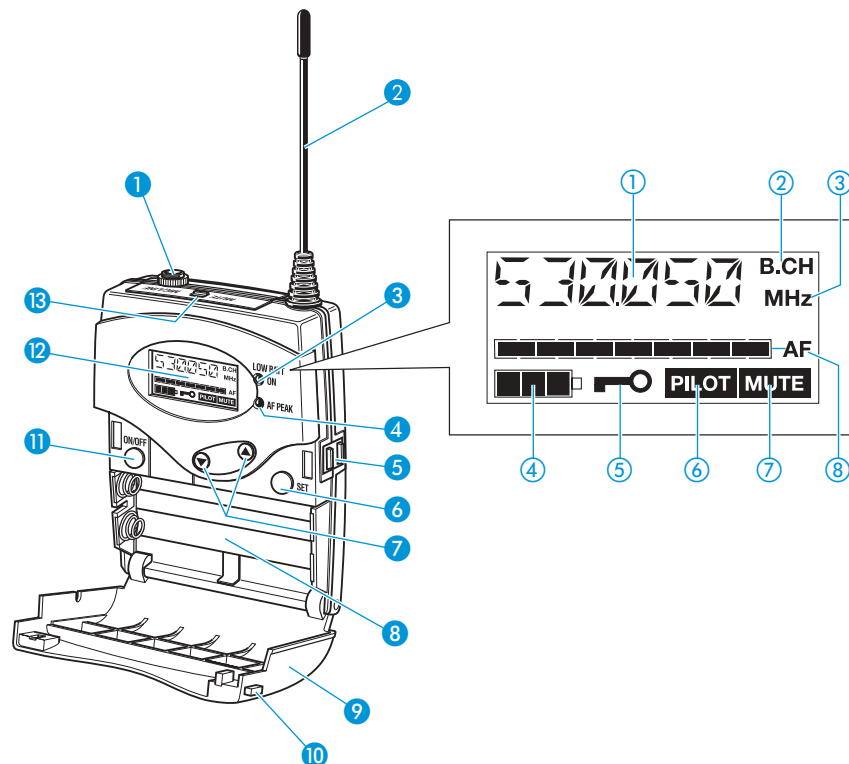

### Operating controls

- ① Microphone/line input (MIC/LINE), 3.5 mm jack socket
- ② Antenna
- ③ Red LED for operation and battery status indication (ON/LOW BAT)
- ④ Yellow LED for audio peak (AF PEAK)
- ⑤ Charging contacts
- ⑥ SET button
- ⑦ ▼/▲ rocker button (DOWN/UP)
- ⑧ Battery compartment
- ⑨ Battery compartment cover
- ⑩ Unlocking button
- ⑪ ON/OFF button (serves as the ESC (cancel) key in the operating menu)
- ⑫ LC display
- ⑬ MUTE switch

### LC display panel

- ① Alphanumeric display
- ② "B.CH" – appears when the channel bank and the channel number are displayed
- ③ "MHz" – appears when the frequency is displayed
- ④ 4-step battery status display
- ⑤ Lock mode icon (lock mode is activated)
- ⑥ "PILOT" display (pilot tone transmission is activated)
- ⑦ "MUTE" display (audio input is muted)
- ⑧ 7-step level display for audio signal "AF"

# SKM 300 G2 radiomicrophone

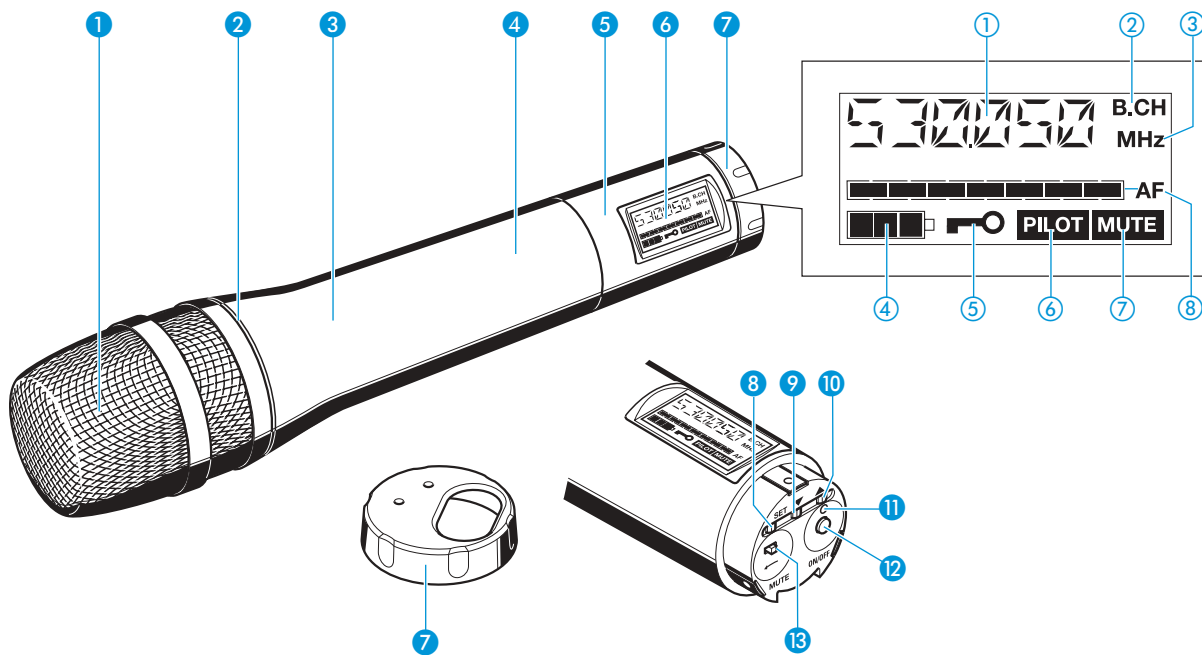

## Operating controls

- ① Sound inlet basket
- ② Color-coded identification ring for microphone heads  
green: MD 835 microphone head  
blue: MD 845 microphone head  
red: ME 865 microphone head
- ③ Body of radiomicrophone
- ④ Battery compartment (not visible from outside)
- ⑤ Display section
- ⑥ LC display
- ⑦ Turnable protective cap for operating controls (shown removed)

The following operating controls become accessible in turn by turning the protective cap:

- ⑧ SET button
- ⑨ ▼ button (DOWN)
- ⑩ ▲ button (UP)
- ⑪ Red LED for operation and battery status indication (ON/LOW BAT)
- ⑫ ON/OFF button (serves as the ESC (cancel) key in the operating menu)
- ⑬ MUTE switch

## LC display panel

- ① Alphanumeric display
- ② "B.CH" – appears when the channel bank and the channel number are displayed
- ③ "MHz" – appears when the frequency is displayed
- ④ 4-step battery status display
- ⑤ Lock mode icon (lock mode is activated)
- ⑥ "PILOT" display (pilot tone transmission is activated)
- ⑦ "MUTE" display (audio input is muted)
- ⑧ 7-step level display for audio signal "AF"



## Indications and displays on the receiver

### Transmitter battery status indication

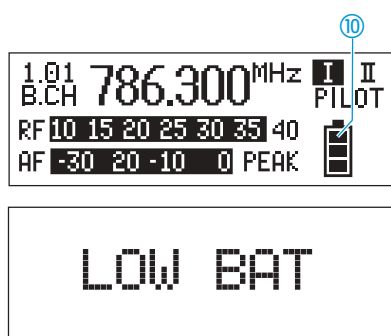

The 4-step transmitter battery status display ⑩ on the receiver display panel provides information on the transmitter's remaining battery/accupack BA 2015 capacity:

3 segments:	capacity approx. 100 %
2 segments:	capacity approx. 70 %
1 segment:	capacity approx. 30 %

Battery icon flashing: LOW BAT  
In addition, the text "LOW BAT" (backlit in red) flashes in alternation with the standard display.

### "MUTE" display

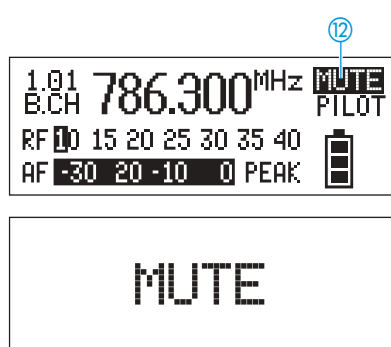

The "MUTE" display ⑫ appears on the display panel and the backlighting of the standard display switches from green to red. In addition, the text "MUTE" flashes in alternation with the standard display when

- the RF signal of the received transmitter is too weak,
- the received transmitter has been muted (with the pilot tone transmission or evaluation activated).

### Modulation display

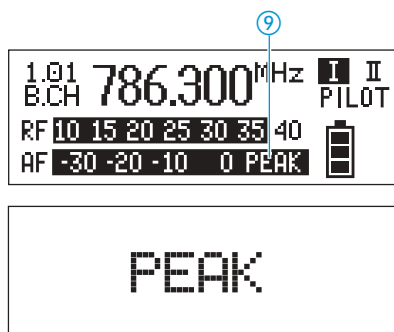

The level display for audio signal "AF" shows the modulation of the received transmitter.

When the transmitter's audio input level is excessively high (AF peak), the receiver's level display for audio signal "AF" ⑨ shows full deflection.

When the transmitter is overmodulated frequently or for an extended period of time, the text "PEAK" (backlit in red) flashes in alternation with the standard display.

### "PILOT" display

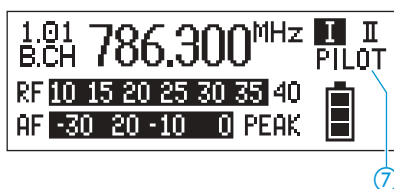

The "PILOT" display ⑦ lights up when the pilot tone evaluation is activated (see "Activating/deactivating the pilot tone transmission or pilot tone evaluation" on page 79).

### Diversity display

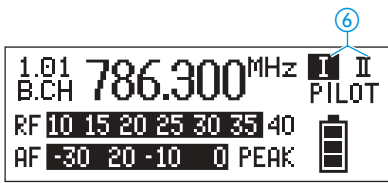

The EM 300 G2 receiver operates on the true diversity principle (see "Diversity reception" on page 85).

The diversity display ⑥ indicates whether diversity section I (i.e. antenna 1) or diversity section II (i.e. antenna 2) is active.

### Button backlighting

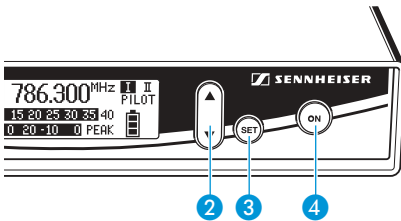

In standby operation, the ON button ④ is backlit in red. When the receiver is switched on, the SET button ③ and the ▲/▼ button ② are additionally backlit in green.

## Indications and displays on the transmitters

### Operation and battery status indication

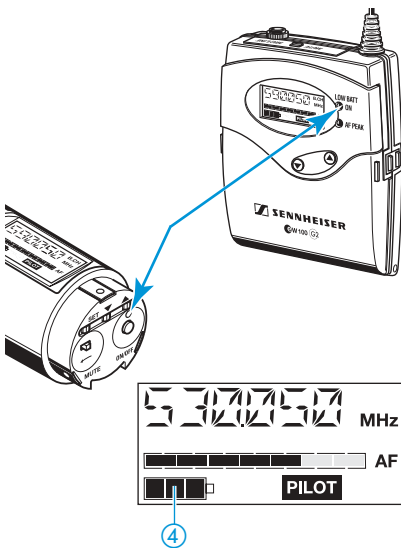

The red LED (LOW BAT/ON) provides information on the current operating state of the transmitter:

Red LED lit up: The transmitter is switched on and the capacity of the batteries/accupack BA 2015 is sufficient.

Red LED flashing: The batteries are/the accupack BA 2015 is going flat (LOW BAT)!

In addition, the 4-step battery status display ④ on the display panel provides information on the remaining battery/accupack BA 2015 capacity.

3 segments: capacity approx. 100 %

2 segments: capacity approx. 70 %

1 segment: capacity approx. 30 %

Battery icon flashing: LOW BAT

### "MUTE" display

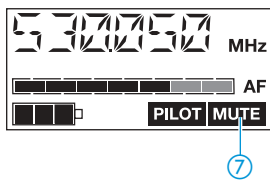

The "MUTE" display ⑦ appears on the display panel when the transmitter is muted (see "Muting the transmitters" on page 65).

### Modulation display



The level display for audio signal "AF" shows the modulation of the transmitter. When the transmitter's audio input level is excessively high, the level display for audio signal "AF" shows full deflection.

### AF peak indication (SK 300 G2 only)

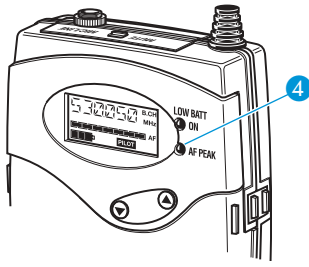

The yellow LED (AF PEAK) ④ at the front of the SK 300 G2 lights up when the audio input level is excessively high (AF peak) and overmodulates the transmitter. At the same time, the 7-step level display for audio signal "AF" shows full deflection for the duration of the overmodulation.

### "PILOT" display

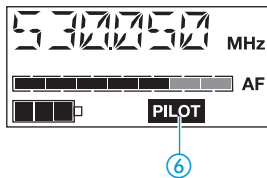

The "PILOT" display ⑥ lights up when the pilot tone evaluation is activated. (see "Activating/deactivating the pilot tone transmission or pilot tone evaluation" on page 79).

### Display backlighting

After pressing a button, the display remains backlit for approx. 15 seconds.

# Preparing the components for use

## EM 300 G2 rack-mount receiver

### Mounting the receiver feet

To ensure that the receiver cannot slip on the surface on which it is placed, four self-adhesive soft rubber feet are supplied.

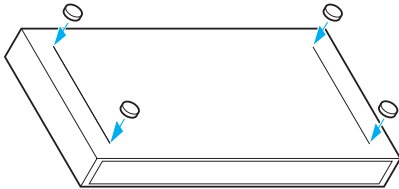

- ▶ Ensure that the base of the receiver is clean before mounting the rubber feet.
- ▶ Fix the rubber feet to the base of the receiver by peeling of the safety paper and fitting them as shown in the diagram on the left.

### Attention!

Some furniture surfaces have been treated with varnish, polish or synthetics which might cause stains when they come into contact with other synthetics. Despite a thorough testing of the synthetics used by us, we cannot rule out the possibility of staining.

### Connecting the antennas

The supplied telescopic antennas can be mounted quickly and easily to the rear of the receiver and are suitable for all applications where – good reception conditions provided – a wireless transmission system is to be used without a large amount of installation work.

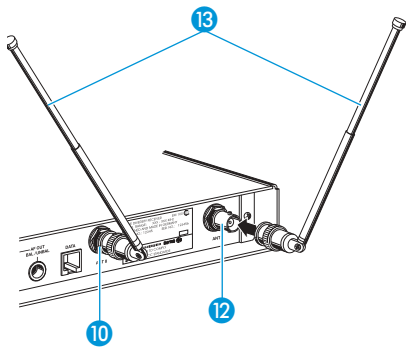

- ▶ Connect the telescopic antennas 13 to the BNC sockets 10 and 12 at the rear of the receiver.
- ▶ Pull the telescopic antennas out and align them upwards in a V-shape. Use remote antennas when the receiver position is not the best antenna position for optimum reception. These are available as accessories.

### Connecting the mains unit

The EM 300 G2 is powered via a mains unit.

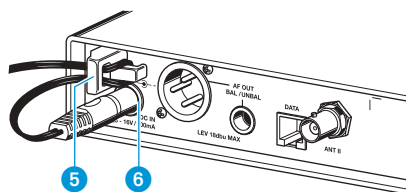

- ▶ Pass the cable through the cable grip 5.
- ▶ Insert the DC connector on the mains cable into the DC socket 6.

## Connecting the amplifier/mixing console

The EM 300 G2's audio outputs are available as an XLR-3M socket **7** and a ¼" (6.3 mm) jack socket **8**, allowing you to simultaneously connect two units (e.g. amplifier, mixing console). The adjusted audio output level is common for both sockets.

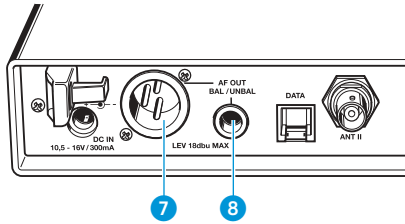

- ▶ Connect the amplifier/mixing console to the XLR-3M socket **7** or the ¼" (6.3 mm) jack socket **8**.

For detailed information on balanced and unbalanced connection, please refer to the section "connector assignment" on page 87.

- ▶ Via the operating menu, adapt the level of the audio output (AF OUT) to the input of the amplifier or mixing console (see "Adjusting the audio output level (EM 300 G2 only)" on page 77).

## Service interface

The service interface **9** is only required for servicing purposes.

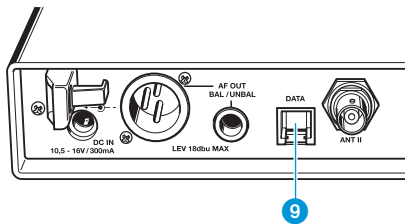

## 19" rack adapter and antenna mount

For mounting one or two receivers into a 19" rack, you require the GA 2 rack adapter (available as an accessory). The GA 2 rack adapter consists of:

- 2 rack mount "ears" **14**
- 1 connecting bar **15**
- 1 connecting plate **16**
- 2 covering plugs **17** for antenna holes
- 12 recessed head screws M 3x6
- 2 recessed head screws M 6x10

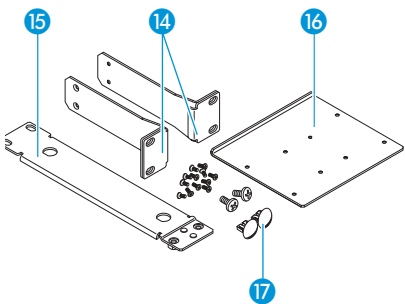

When mounting only one receiver into a rack, you can use the AM 2 antenna mount (available as an accessory) to mount the transmitter's antenna connection to the front of the GA 2 rack adapter. The AM 2 antenna mount consists of:

- 2 BNC extension cables (screw-in BNC socket **18** to BNC connector **19**)
- 2 plains washers
- 2 nuts

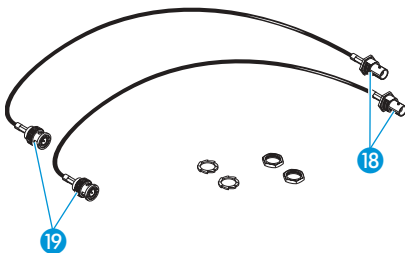

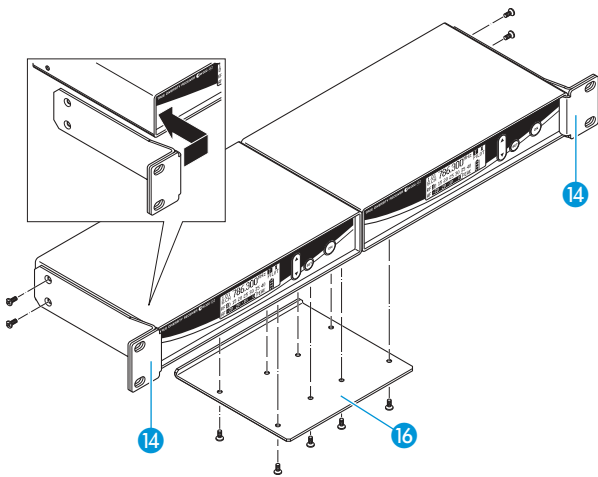

To mount two EM 300 G2 into a rack:

- ▶ Place the two receivers side by side onto a flat surface, their bottom sides facing upwards.
- ▶ Align the connecting plate 16 over the holes in the bottom sides of the receivers.
- ▶ Secure the connecting plate 16 to the receivers using eight of the supplied recessed head screws (M 3x6).
- ▶ Hook the two rack mount "ears" 14 to the front panels of the receivers.
- ▶ Secure the rack mount "ears" to the receivers using two of the supplied recessed head screws (M 3x6) respectively.
- ▶ Slide the receivers into a 19" rack.
- ▶ Screw the rack mount "ears" tight.

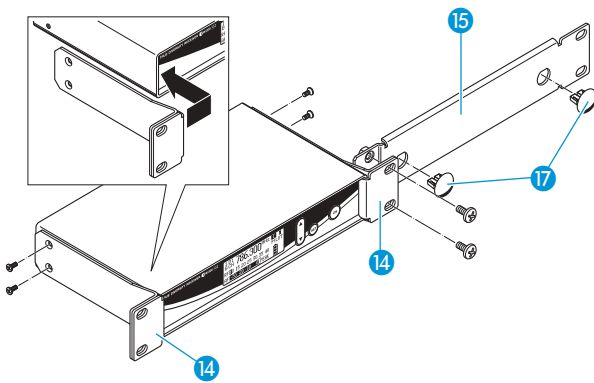

When mounting only one receiver into a rack, use the connecting bar 15 instead of the second receiver.

- ▶ Hook the two rack mount "ears" 14 to the front panel of the receiver.
- ▶ Secure the rack mount "ears" to the receiver using two of the supplied recessed head screws (M 3x6) respectively.
- ▶ Secure the connecting bar 15 to one of the rack mount "ears" 14 using two of the supplied recessed head screws (M 6x10).
- ▶ If you are not front mounting the antennas, insert the two covering plugs 17 into the antenna holes of the connecting bar.
- ▶ Slide the receiver into a 19" rack and screw the rack mount "ears" tight.

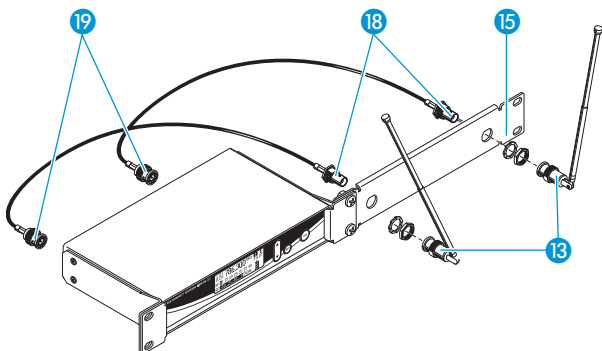

To mount the receiver's antenna connection to the front of the GA 2 rack adapter using the AM 2 antenna mount:

- ▶ Screw the two BNC sockets 18 of the BNC extension cables to the connecting bar 15 using the supplied plain washers and nuts.
- ▶ Connect the two BNC connectors 19 to the BNC sockets 10 and 12 at the rear of the receiver.
- ▶ Slide the receiver into a 19" rack.
- ▶ Screw the rack mount "ears" tight.
- ▶ Connect the two telescopic antennas 13 to the two BNC sockets 18.
- ▶ Pull the telescopic antennas out and align them upwards in a V-shape.

## SK 300 G2 bodypack transmitter

### Inserting and replacing the batteries

For powering the SK 300 G2 bodypack transmitter, use two 1.5 V AA size batteries.

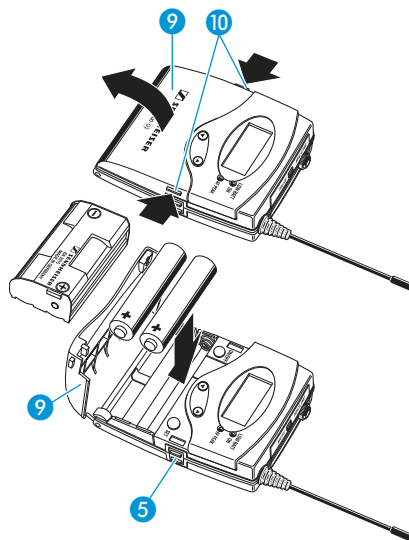

- ▶ Press the two unlocking buttons (10) and open the battery compartment cover (9).
- ▶ Insert the two batteries as shown in the diagram on the left. Please observe correct polarity when inserting the batteries.
- ▶ Close the battery compartment. The battery compartment cover (9) locks into place with an audible click.

### Inserting and charging the accupack

The bodypack transmitter can also be powered via the rechargeable Sennheiser BA 2015 accupack. Insert the accupack into the battery compartment as described above.

The transmitter has two charging contacts (5) and a sensing contact on its short sides. The accupack can be recharged while remaining in the transmitter. Insert the transmitter into the L 2015 charger (see operating manual of the L 2015 charger).

#### Note:

For accupack operation of the transmitter, only use the BA 2015 accupack. In order to ensure optimum operational reliability. For charging the accupack, only use the L 2015 charger. Both the accupack and the charger are available as accessories.

The accupack is fitted with an integrated sensor which is – via a third contact – monitored by the electronics of the transmitter and the charger. The sensor is necessary for the following control purposes:

- The taking into account of the different voltage characteristics of primary cells (batteries) and accupacks. The battery status indications on the displays, the transmission of transmitter battery status information to the rack-mount receivers and the switch-off thresholds at the end of the operating time are corrected correspondingly. Due to the missing sensor, individual rechargeable battery cells will not be identified as accupacks.
- The monitoring of the accupack temperature during charging in the L 2015 charger.
- The prevention of improper charging of inserted primary cells (batteries). Due to the missing sensor, individual rechargeable battery cells will also not be charged in the L 2015 charger.

### Connecting the microphone/line cable

The microphone/line input is designed for the connection of both condenser microphones and instruments (e.g. guitars). DC powering of the condenser microphones is via the microphone/line input.

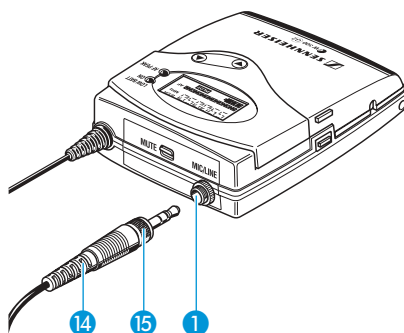

- ▶ Connect the 3.5 mm jack plug (14) from the microphone/line cable to the 3.5 mm jack socket (MIC/LINE) (1).
- ▶ Lock the 3.5 mm jack plug by screwing down the coupling ring (15).
- ▶ Via the operating menu, adjust the sensitivity of the microphone/line input (see "Adjusting the sensitivity (transmitters only)" on page 76).

### Attaching the microphones

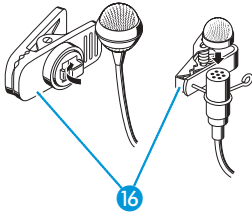

- ▶ Use the microphone clips 16 to attach the ME 2 and ME 4 clip-on microphones to clothing (e.g. tie, lapel).
- ▶ Adjust the ME 3 headmic so that a comfortable and secure fit is ensured.

### Positioning the microphones

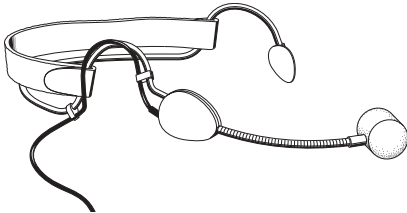

The ME 3 and ME 4 microphones are directional microphones, i.e. their sound inlet should always be directed towards the sound source (e.g. mouth).

The ME 2 with omni-directional pick-up pattern picks up sound equally from all directions. It is the best choice if movements of the speaker's head have to be compensated for. However, it should be attached as close as possible to the sound source.

Adjust the sensitivity correctly for all microphones/usages (see "Adjusting the sensitivity (transmitters only)" on page 76).

### Attaching the bodypack transmitter to clothing

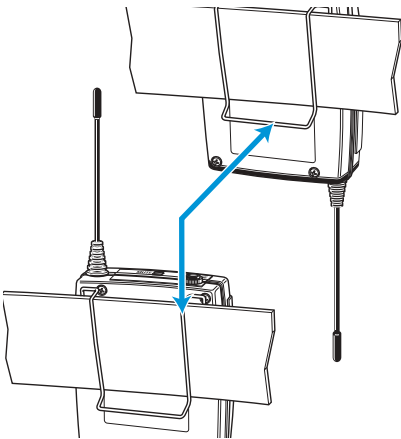

The bodypack transmitter is attached to clothing (e.g. belt, waistband) with the supplied belt clip.

The clip is detachable so that you can also attach the bodypack transmitter with the antenna pointing downwards. To do so, withdraw the clip from its fixing points and attach it the other way round.

The BPP 1 bodypack pouch (available as an accessory) helps to protect the bodypack transmitter against moisture.



## SKM 300 G2 radiomicrophone

### Inserting and replacing the batteries

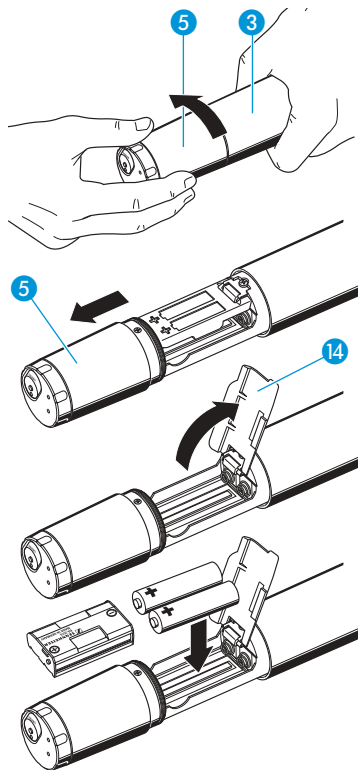

For powering the SKM 300 G2 radiomicrophone, you can either use two 1.5 V AA size batteries or the rechargeable Sennheiser BA 2015 accupack.

- ▶ Unscrew the display section 5 from the radiomicrophone's body 3 by turning it counterclockwise.
- ▶ Slide back the display section 5 as far as it will go.
- ▶ Open the battery compartment cover 14.
- ▶ Insert the two batteries or the BA 2015 accupack as shown in the diagram on the left. Please observe correct polarity when inserting the batteries/accupack.
- ▶ Close the battery compartment cover 14.
- ▶ Push the battery compartment into the radiomicrophone's body.
- ▶ Screw the display section tight.

#### Note:

For important informations on charging the accupack see "Inserting and replacing the batteries" on page 61.

### Changing the microphone head

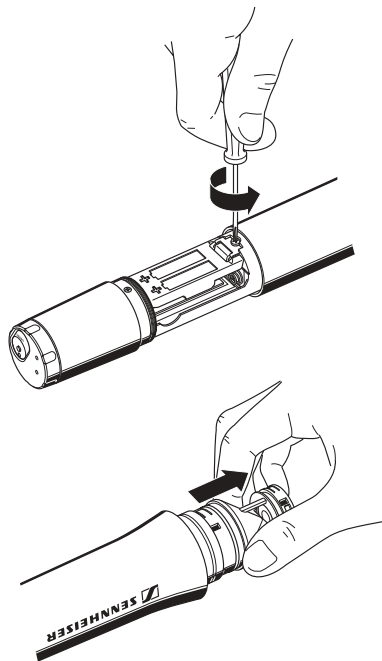

- ▶ First remove the batteries/accupack as described above and leave the radiomicrophone open.
- ▶ Unscrew the sound inlet basket.
- ▶ Loosen the screw and put it to one side.
- ▶ Gently ease the capsule out of the contacts and then pull it out of the housing as shown. Do not touch the contacts and the diaphragm!
- ▶ Insert the new capsule.
- ▶ Secure the capsule by tightening the screw.

#### Note:

The screw mechanically secures the microphone capsule. If the screw is missing, malfunctions may occur during tough use.

- ▶ Put on the sound inlet basket and identification ring supplied with the new microphone head (NB: do NOT use the old basket, as the different heads use slightly differing internal foam) and screw it tight.
- ▶ Insert the batteries/accupack.
- ▶ Close the radiomicrophone and put it into operation.

#### Note:

Microphone capsule, sound inlet basket and foam insert form an acoustic unit and must therefore always be exchanged all together. Each microphone head comes with a color-coded identification ring to distinguish different microphone heads from each other (green = MD 835, blue = MD 845, red = ME 865).

# Using the components

## Switching the components on/off

ew 300 G2 transmitters and receivers can only be switched off when the standard display is shown on the display panel. Within the operating menu, the **ON** button (receiver) or the **ON/OFF** button (transmitters) serves as the ESC (cancel) key, i.e you cancel your entry and return to the standard display.

### Note:

Remove the batteries or the accupack when the units will not be used for extended periods of time.

### Switching the rack-mount receiver on/off

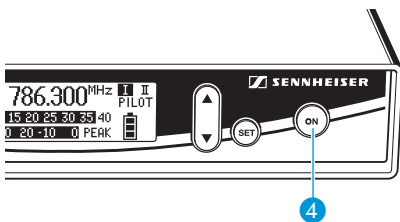

- ▶ Press the **ON** button **4** to switch the receiver on.
- ▶ To switch the receiver off, press the **ON** button until "OFF" appears on the display.

### Switching the bodypack transmitter on/off

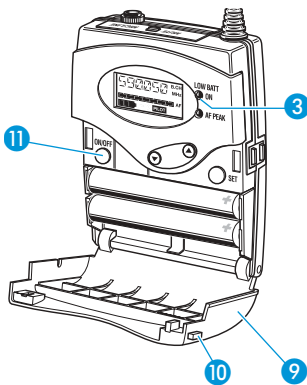

- ▶ Press the two unlocking buttons **10** and open the battery compartment cover **9**.
- ▶ Press the **ON/OFF** button **6** to switch the bodypack transmitter on. The red LED **3** lights up.
- ▶ To switch the bodypack transmitter off, press the **ON/OFF** button **11** until "OFF" appears on the display. The red LED **3** goes off.
- ▶ Close the battery compartment. The battery compartment cover **9** locks into place with an audible click.

### Switching the radiomicrophone on/off

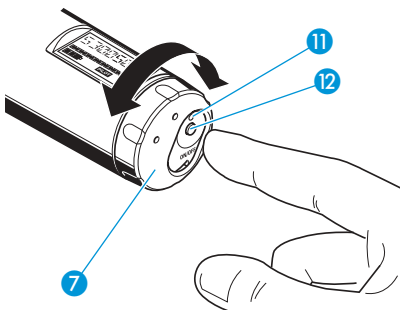

- ▶ Turn the protective cap **7** at the bottom of the radiomicrophone so that the **ON/OFF** button **12** becomes accessible.
- ▶ Press the **ON/OFF** button to switch the radiomicrophone on. The red LED **11** lights up.
- ▶ To switch the radiomicrophone off, press the **ON/OFF** button **12** until "OFF" appears on the display. The red LED **11** goes off.

## Muting the transmitters

Both transmitters have a **MUTE** switch that noiselessly mutes the transmitter's audio signal without switching the transmitter off.

### Muting the SK 300 G2 bodypack transmitter



- ▶ Set the **MUTE** switch 13 to the position 'MUTE'. The "MUTE" display appears on the transmitter display panel. Provided that the pilot tone function is activated on both the transmitter and the receiver, the "MUTE" display also appears on the receiver display panel.
- ▶ Set the **MUTE** switch back to the original position to retransmit the audio signal.

### Muting the SKM 300 G2 radiomicrophone

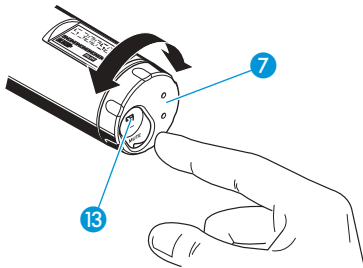

- ▶ Turn the protective cap 7 at the bottom of the radiomicrophone so that the **MUTE** switch 13 becomes accessible.
- ▶ Set the **MUTE** switch to the position 'MUTE'. The "MUTE" display appears on the transmitter display panel. Provided that the pilot tone function is activated on both the transmitter and the receiver, the "MUTE" display also appears on the receiver display panel.
- ▶ Set the **MUTE** switch back to the original position to retransmit the audio signal.

## Activating/deactivating the lock mode

ew 300 G2 transmitters and receivers have a lock mode that can be activated or deactivated via the operating menu (see "Activating/deactivating the lock mode" on page 80). The lock mode prevents that the transmitter or receiver is accidentally programmed or switched off during operation.

# The operating menu

A special feature of the Sennheiser ew 300 G2 series is the similar, intuitive operation. As a result, the units are easy to operate and adjustments to the settings can be made quickly and “without looking” – even in stressful situations, for example on stage or during a live show or presentation.

## The buttons

Buttons	Mode	To ...
ON/OFF or ON (EM 300 G2 only)	Standard display	turn the transmitter or receiver on and off
	Operating menu	cancel the entry and return to the standard display
	Setting mode	cancel the entry and return to the standard display
SET	Standard display	get into the operating menu
	Operating menu	get into the setting mode of the selected menu
	Setting mode	store the settings and return to the previous menu level
▲/▼	Standard display	without function
	Operating menu	change to the previous menu (▲) or change to the next menu (▼)
	Setting mode	adjust the setting of the selected menu: option (▲/▼)

## Overview of menus

Receiver		Transmitters	
Display	Function of the menu	Display	Function of the menu
Bank	Switching between channel banks	BANK	Switching between channel banks
Channel	Switching between the channels in a channel bank	CHAN	Switching between the channels in a channel bank
Tune	Setting a receiving frequency for the channel bank “U” (user bank)	TUNE	Setting a transmission frequency for the channel bank “U” (user bank)
—	—	SENSIT	Adjusting the sensitivity (AF)
Scan	Scanning the channel banks for free channels	—	—
AF Out	Adjusting the audio output level	—	—
Squelch	Adjusting the squelch threshold	—	—
Display	Selecting the standard display	DISPLY	Selecting the standard display
Name	Entering a name	NAME	Entering a name
Reset	Loading the factory-preset default settings	RESET	Loading the factory-preset default settings
Pilot	Activating/deactivating the pilot tone evaluation	PILOT	Activating/deactivating the pilot tone transmission
Lock	Activating/deactivating the lock mode	LOCK	Activating/deactivating the lock mode
LCD Contr	Adjusting the contrast of the graphic display	—	—
Exit	Exiting the operating menu and returning to the standard display	EXIT	Exiting the operating menu and returning to the standard display

## Working with the operating menu

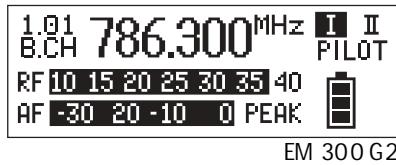

By way of example of the "Tune" menu, this section describes how to use the operating menu.

After switching the unit on, the standard display is shown on the display panel.

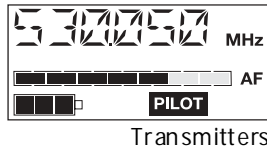

Transmitters

### Getting into the operating menu

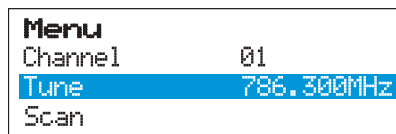

- ▶ Press the **SET** button to get from the standard display into the operating menu. The last menu selected flashes on the display. With the receiver, the current setting is additionally displayed.



### Selecting a menu



- ▶ Press the **▲/▼** buttons to select a menu.
- ▶ Press the **SET** button to get into the setting mode of the selected menu. With the transmitters, the current setting that can be adjusted flashes on the display. With the receiver, the name of the menu and the current setting are displayed.



### Adjusting a setting

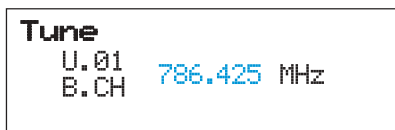

- ▶ Press the **▲/▼** buttons to adjust the setting. By briefly pressing the **▲/▼** buttons, the display jumps either forwards or backwards to the next setting. In the "Channel", "Tune" and "Name" menu, the **▲/▼** buttons feature a "fast search" function. If you hold down a button, the display cycles continuously. The "fast search" function allows you to get fast and easily to your desired setting. With the transmitters, the new setting flashes on the display until it is stored.



### Storing a setting



- ▶ Press the **SET** button to store the setting. "Stored" appears on the display, indicating that the setting has been stored. The display then returns to the top menu level.



With most menus, new settings become effective immediately without having to be stored. An exception are the "BANK", "CHAN", "TUNE" and "RESET" menus of the transmitters and the "Reset" menu of the receiver. With these menus, new settings only become effective after they have been stored and "Stored" had appeared on the display.

### Exiting the operating menu

- ▶ Select the "Exit" menu to exit the operating menu and to return to the standard display.

When you have entered the operating menu, the **ON/OFF** button or the **ON** button (EM 300 G2 receiver only) serves as the ESC (cancel) key, i.e. by briefly pressing the **ON/OFF** or **POWER** button, you cancel your entry and return to the standard display.

Menu	
Lock	
Exit	
Bank	1

EXIT

# Operating menu of the receiver

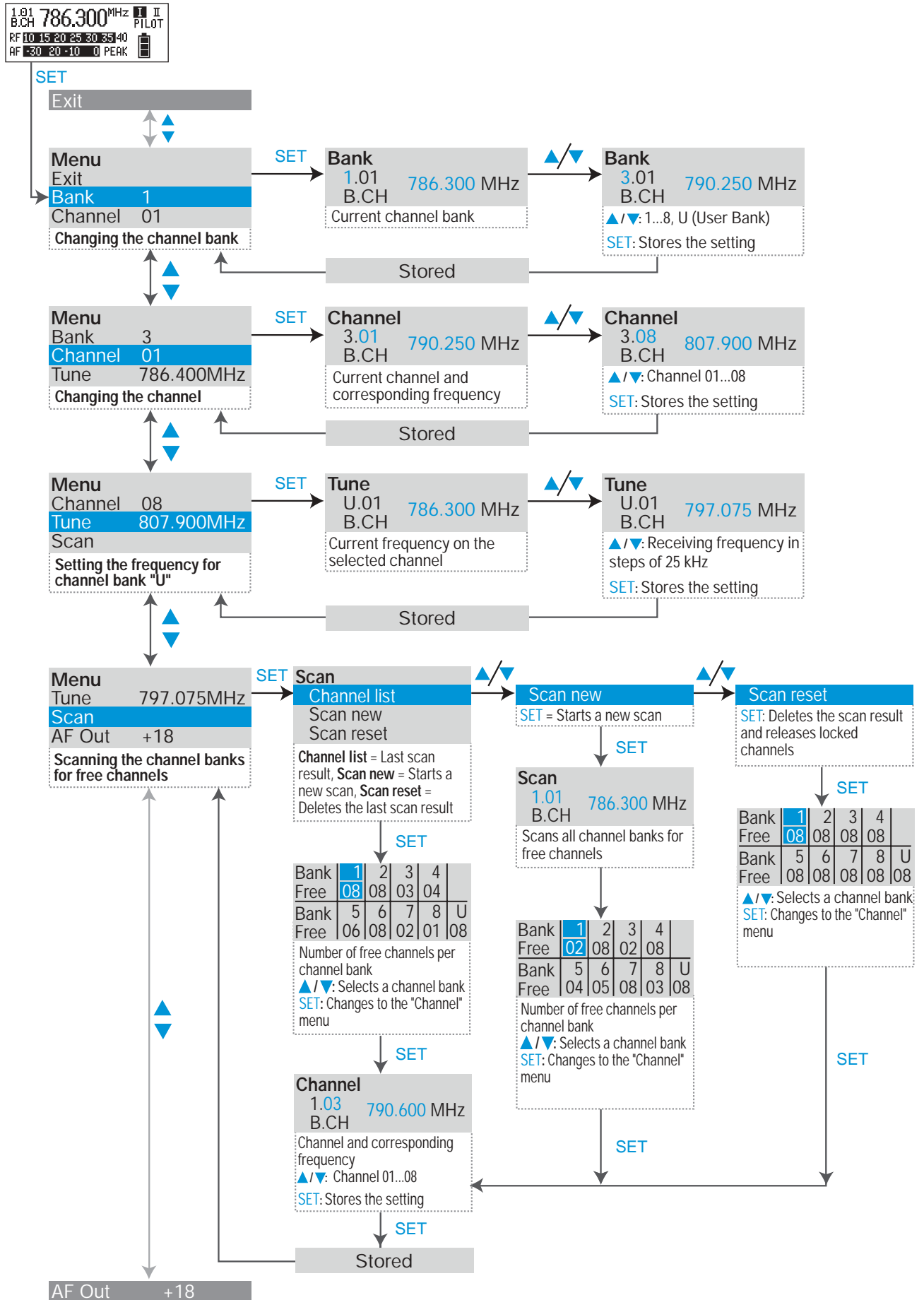

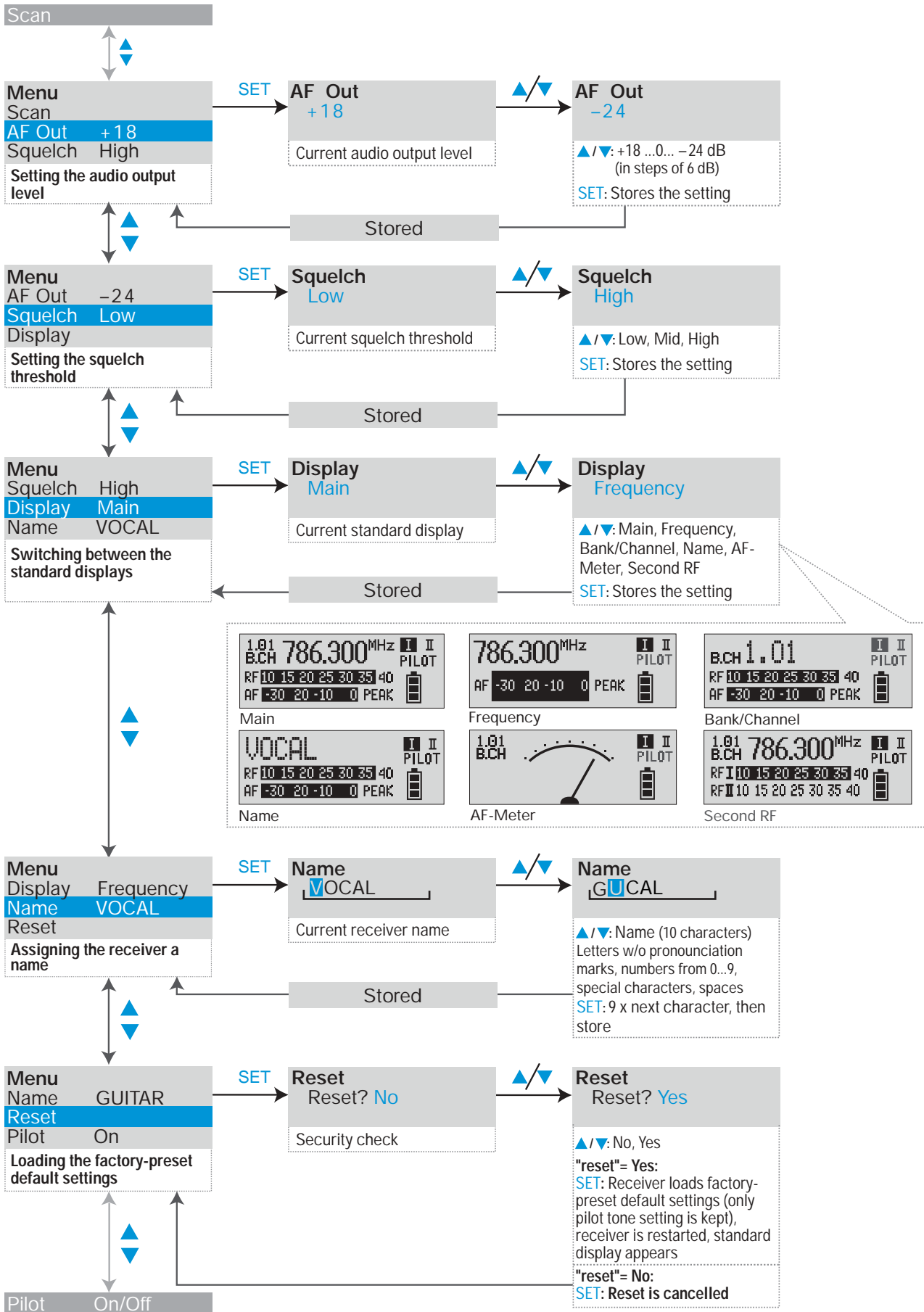



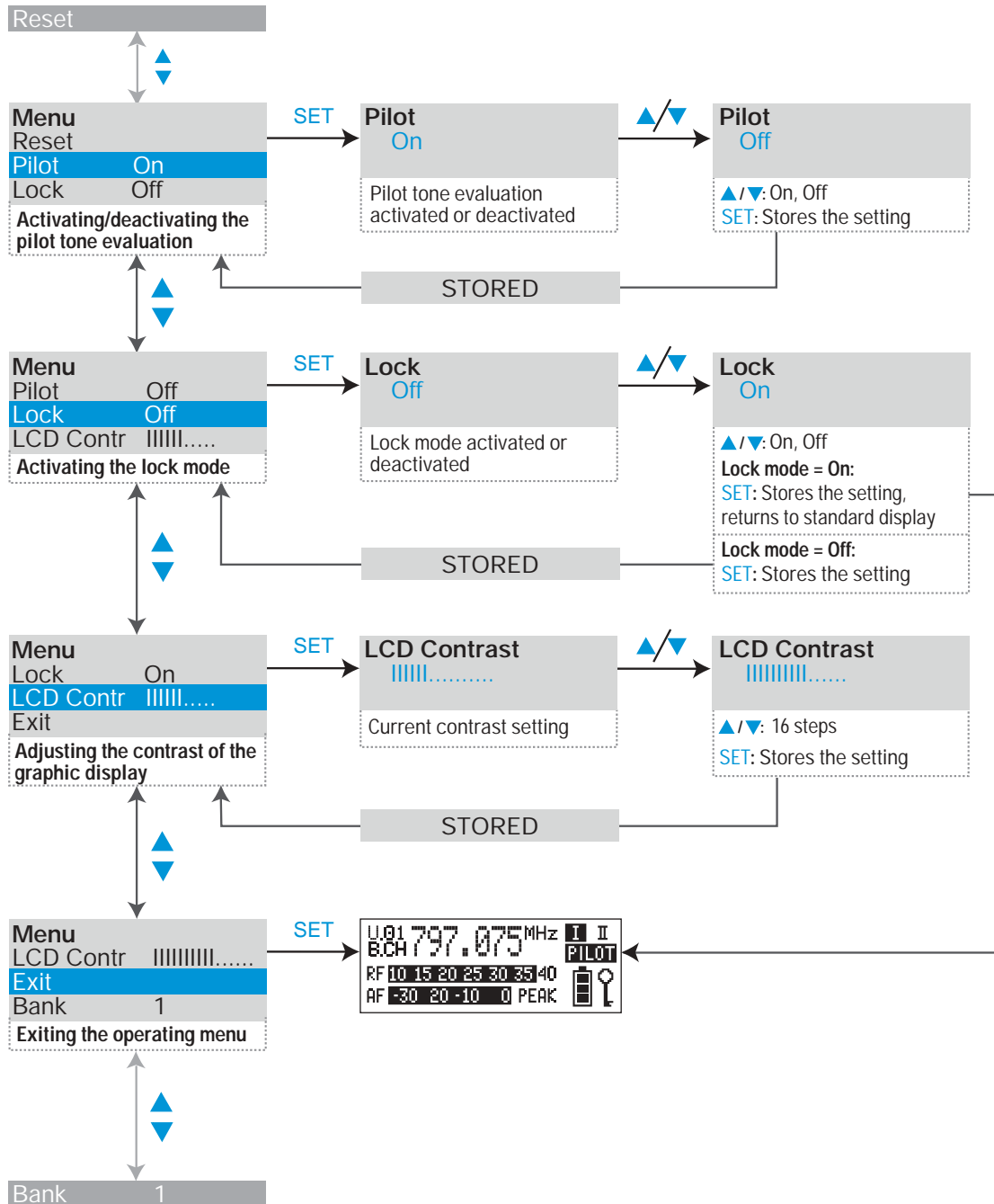

# Operating menu of the transmitters

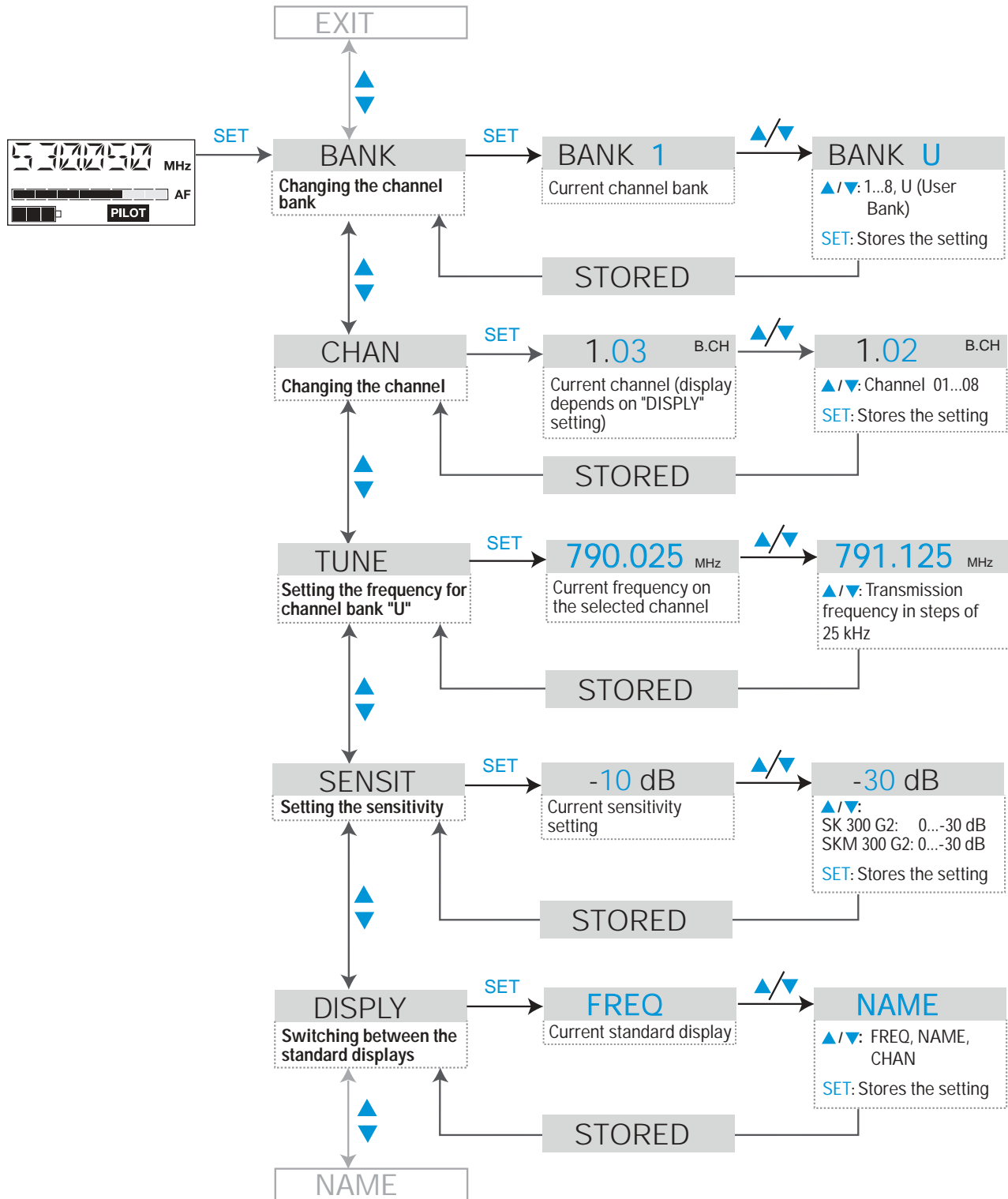

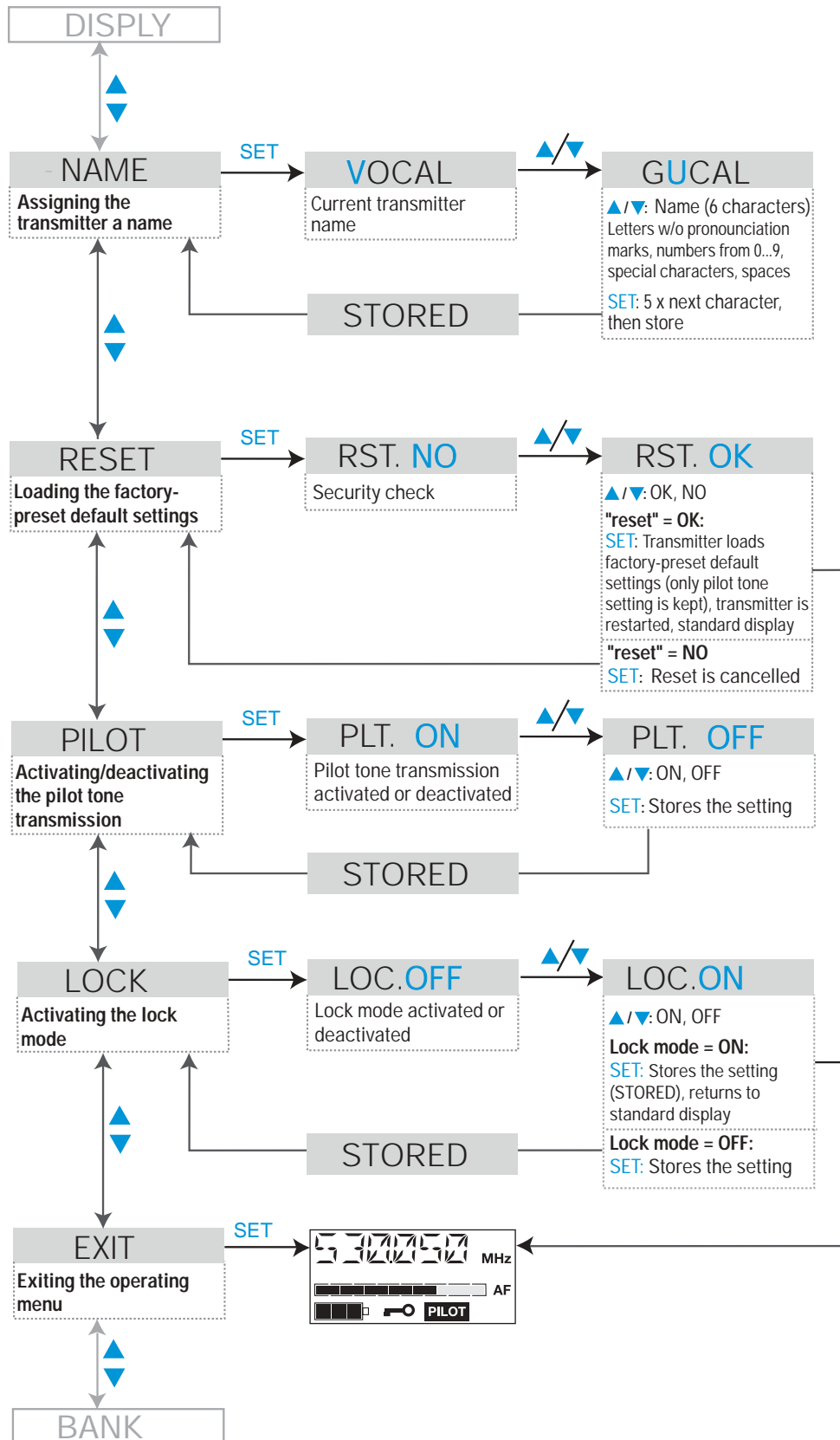

# Adjustment tips for the operating menu

## Switching between channel banks

### BANK Bank

Via the “Bank” menu, you can switch between the nine channel banks. The channel banks “1” to “8” have eight switchable channels that are factory-preset to a transmission/receiving frequency (see “The channel bank system” on page 50). The channel bank “U” (user bank) has eight switchable channels to store your selection out of 1440 transmission/receiving frequencies that are freely selectable within the preset frequency range.

When switching from one channel bank to another, the channel with the lowest channel number is automatically displayed. If, during the last scan of this channel bank, an interfering frequency was detected on the channel with the lowest channel number (see “Scanning the channel banks for free channels (EM 300 G2 only)” on page 75), the receiver display panel automatically displays the next free channel.

## Switching between the channels in a channel bank

### CHAN Channel

Via the “Channel” menu, you can switch between the eight channels in a channel bank.

Always set the transmitter and the receiver of a transmission link to the same channel. After scanning the channel banks (see “Scanning the channel banks for free channels (EM 300 G2 only)” on page 75), only the free channels are displayed. Set the transmitter to one of the free channels.

## Selecting the frequencies to be stored in the channel bank “U”

### TUNE Tune

Via the “Tune” menu, you can select the frequencies to be stored in the channel bank “U” (user bank).



When you have selected one of the channel banks “1” to “8” and then select the “Tune” menu, the transmitter or receiver automatically switches to channel 01 of the channel bank “U”. In this case, “U.01” briefly appears on the display.

- ▶ Use the ▲/▼ buttons to select the desired transmission or receiving frequency. Transmission and receiving frequencies are tunable in 25-kHz steps within a switching bandwidth of 36 MHz max. For intermodulation-free frequencies, please refer to the enclosed frequency table.

## Scanning the channel banks for free channels (EM 300 G2 only)

### Scan

Before putting one or several transmission links into operation, you should scan the channel banks for free channels.

#### Scan

Channel list  
Scan new  
Scan reset

Bank	1	2	3	4	
Free	08	08	03	04	
Bank	5	6	7	8	U
Free	06	08	02	01	08

#### Channel

1.01  
B.CH 786.300 MHz

### Displaying the last scan result

- ▶ Select the "Scan" menu.
- ▶ Select "Channel list" to display the last scan result. The number of free channels is displayed for all channel banks.

- ▶ For further details, select a channel bank by using the ▲/▼ buttons and then press the SET button. This gets you into the "Channel" menu where you can select a channel of this channel bank or display the frequency of a channel.

### Starting the scan

- ▶ Before starting the scan, switch all transmitters of your system off, since channels used by switched-on transmitters will not be displayed as "free channels".

#### Scan

Channel list  
Scan new  
Scan reset

Bank	1	2	3	4	
Free	08	08	03	04	
Bank	5	6	7	8	U
Free	06	08	02	01	08

- ▶ Select the "Scan" menu.
- ▶ Select "Scan new" and confirm your selection by pressing the SET button. After the scan is completed, the number of free channels is displayed for all channel banks. Channels that are used or subject to interference are locked and cannot be selected.
- ▶ For further details, select a channel bank by using the ▲/▼ buttons and then press the SET button. This gets you into the "Channel" menu where you can select a channel of this channel bank or display the frequency of a channel.

### Releasing locked channels

#### Scan

Channel list  
Scan new  
Scan reset

Bank	1	2	3	4	
Free	08	08	08	08	
Bank	5	6	7	8	U
Free	08	08	08	08	08

- ▶ Select the "Scan" menu.
- ▶ Select "Scan reset" and confirm your selection by pressing the SET button. The last scan result is deleted and all channels can now be selected again.

## Multi-channel operation

For multi-channel operation, only use the free channels in a channel bank.

Before putting the transmission links into operation, we recommend performing an auto scan.

- ▶ Scan a receiver for free channels.
- ▶ Select a channel bank with a sufficient number of free channels.
- ▶ Apply the scan result to all other transmitters and receivers.

Bank	1	2	3	4	
Free	08	08	03	04	
Bank	5	6	7	8	U
Free	06	08	02	01	08

## Adjusting the sensitivity (transmitters only)

Via the “SENSIT” menu, you can adjust the transmitters’ input sensitivity.

The input sensitivity is adjusted too high when close talking distances, speakers with loud voices or loud music passages cause overmodulation in the transmission link. In this case, the SK 300 G2’s yellow LED (AF PEAK) ④ will light up and the receiver’s level display for audio signal “AF” will show full deflection (see “AF peak indication (SK 300 G2 only)” on page 57).

If, on the other hand, the sensitivity is adjusted too low, the transmission link will be undermodulated, which would result in a signal with high background noise.

The sensitivity is correctly adjusted when the level display for audio signal “AF” ⑨ shows full deflection only during the loudest passages.

### Note:

For monitoring the adjusted sensitivity, the transmitter’s level display for audio signal “AF” always indicates the audio level – even if the transmitter is muted.

The following figures are a guide to the best settings:

- Loud music/vocals: –30 to –20 dB
- Presentations: –20 to –10 dB
- Interviews: –10 to 0 dB
- Musical instruments:
  - electric guitars with single coil pickups: –10 to 0 dB
  - electric guitars with humbucker pickups: –20 to –10 dB
  - guitars with active electronics (active pickups, active EQs, piezo pickups): –30 to –20 dB

### SENSIT

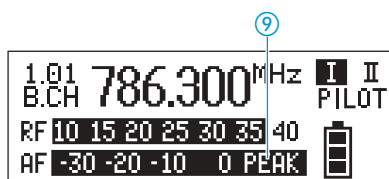
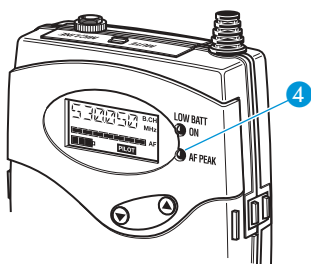

## Adjusting the audio output level (EM 300 G2 only)

### AF Out

Via the "AF Out" menu, you can adjust the audio output level of the receivers. The level can be adjusted in eight steps. Adapt the level of the audio output (AF OUT) to the input of the connected unit. The following figures are a guide to the best settings:

Line level input: 0 to +18 dB

Microphone level input: -24 to -6 dB

## Adjusting the squelch threshold (EM 300 G2 only)

### Squelch

The receiver is equipped with a squelch that can be adjusted via the "Squelch" menu. The squelch eliminates annoying noise when the transmitter is switched off. It also suppresses sudden noise when there is no longer sufficient transmitter power received by the receiver.

#### Note:

Before adjusting the squelch threshold to a different setting, set the volume on a connected amplifier to the minimum.

There are three possible squelch settings:

- Low = low
- Mid = middle
- High = high

Selecting the setting (Low) reduces the squelch threshold, selecting the setting (High) increases the squelch threshold. Adjust the squelch threshold – with the transmitter switched off – to the lowest possible setting that suppresses hissing noise.

#### IMPORTANT!

#### Notes:

If the squelch threshold is adjusted too high, the transmission range will be reduced. Therefore, always adjust the squelch threshold to the lowest possible setting.

When in the setting mode of the "Squelch" menu, pressing the ▼ button (DOWN) for more than three seconds will switch the squelch off. "Off" appears on the display. If no RF signal is being received, hissing noise will occur. This setting is for test purposes only.

## Selecting the standard display

### DISPLY Display

Via the “Display” menu, you can select the standard display:

#### EM 300 G2 rack-mount receiver

Selectable standard display	Contents of standard display
“Main” (standard display)	
“Frequency” (display of the frequency)	
“Bank/Channel” (display of the channel bank and channel number)	
“Name” (display of the freely selectable name)	
“AF meter” (graphic display of the AF level)	
“Second RF” (display of the RF levels of the two diversity sections)	

#### SK 300 G2 body pack transmitter and SKM 300 G2 radiomicrophone

Selectable standard display	Contents of standard display
“FREQ”	
“NAME”	
“CHAN”	



## Entering a name

### NAME Name

Via the “Name” menu, you can enter a freely selectable name for each transmitter and receiver. You can, for example, enter the name of the performer for whom the adjustments have been made.

The name can be displayed on the standard display and can consist of up to six characters (transmitters) and up to ten characters (receiver) such as:

- letters (without pronunciation marks),
- numbers from 0 to 9,
- special characters e.g. () - . \_ and spaces.

To enter a name, proceed as follows:

- ▶ Press the **SET** button to get into the setting mode of the “Name” menu. The first segment starts flashing on the display.
- ▶ With the **▲/▼** buttons you can now select a character. By briefly pressing a button, the display jumps either forwards or backwards to the next character. If you hold down a button, the display starts cycling continuously.
- ▶ Press the **SET** button to change to the next segment and select the next character.
- ▶ Have you entered the name completely? Press the **SET** button to store your setting and to return to the previous menu level.

## Loading the factory-preset default settings

### RESET Reset

Via the “Reset” menu, you can load the factory-preset default settings. Only the selected setting for the pilot tone remains unchanged. After the reset, the unit is restarted and the standard display is shown on the display panel.

## Activating/deactivating the pilot tone transmission or pilot tone evaluation

### PILOT Pilot

Via the “Pilot” menu, you can activate or deactivate the pilot tone transmission of the transmitters and the pilot tone evaluation of the receiver.

The pilot tone supports the squelch function (Squelch) and protects against interference due to RF signals from other units. The transmitter adds an inaudible signal, known as the pilot tone, to the transmitted signal. The receiver detects and evaluates the pilot tone, and is thus able to identify the signal of the matching transmitter and mute all others.

Transmitters of the ew 300 series (first generation) do not transmit a pilot tone and the receiver of the ew 300 series (first generation) cannot evaluate the pilot tone. Nevertheless, you can combine units of the ew 300 series (first generation) with units of the ew 300 G2 series (second generation).

However, when combining units, please observe the following:

- With an ew 300 G2 transmitter and the ew 300 G2 receiver:  
Activate the pilot tone function with both transmitter and receiver.
- With an ew 300 transmitter and the ew 300 G2 receiver or vice versa:  
Deactivate the pilot tone function with the ew 300 G2 transmitter or receiver.

## Activating/deactivating the lock mode

### LOCK Lock



EM 300 G2

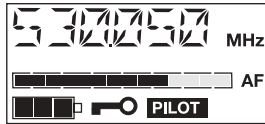

Transmitters

Via the "Lock" menu, you can activate or deactivate the lock mode.

The lock mode prevents that the transmitter or receiver is accidentally programmed or switched off during operation. The lock mode icon on the display indicates that the lock mode is activated.

To deactivate the lock mode, first press the **SET** button and then press the **▲/▼** buttons to select "Lock Off". If you confirm your selection by pressing the **SET** button, the buttons can be operated as usual.

## Adjusting the contrast of the graphic display (EM 300 G2 only)

### LCD-Contr

Via the "LCD Contr" menu, you can adjust the contrast of the graphic display in 16 steps.

## Exiting the operating menu

### EXIT Exit

Via the "Exit" menu, you can exit the operating menu and return to the standard display.

## If problems occur...

### Error checklist

Problem	Possible cause	Possible solution
No operation indication	Batteries are flat or accupack is flat	Replace the batteries or recharge the accupack
	No mains connection (EM 300 G2)	Check the connections of the mains unit
No RF signal	Transmitter and receiver are not on the same channel	Set transmitter and receiver to the same channel
	Transmitter is out of range	Check the squelch threshold setting (see "Adjusting the squelch threshold (EM 300 G2 only)" on page 77) or reduce the distance between transmitter and receiving antenna
RF signal available, no audio signal, "MUTE" display appears on the display panel	Transmitter is muted ("MUTE")	Deactivate the muting function
	Receiver's squelch threshold is adjusted too high	See "Adjusting the squelch threshold (EM 300 G2 only)" on page 77
	Transmitter doesn't transmit a pilot tone	See "Activating/deactivating the pilot tone transmission or pilot tone evaluation" on page 79
Audio signal has a high level of background noise	Transmitter sensitivity is adjusted too low	See "Adjusting the sensitivity (transmitters only)" on page 76
	Receiver's AF output level is adjusted too low	See "Adjusting the audio output level (EM 300 G2 only)" on page 77
Audio signal is distorted	Transmitter sensitivity is adjusted too high	See "Adjusting the sensitivity (transmitters only)" on page 76
	Receiver's AF output level is adjusted too high	See "Adjusting the audio output level (EM 300 G2 only)" on page 77
No access to a certain channel	During scanning, an RF signal has been detected on this channel and the channel has been locked	See "Scanning the channel banks for free channels (EM 300 G2 only)" on page 75
	During scanning, a transmitter of your system operating on this channel has not been switched off	See "Multi-channel operation" on page 76

If problems occur that are not listed in the above table or if the problems cannot be solved with the proposed solutions, please contact your local Sennheiser agent for assistance.

## Recommendations and tips

### ... for the ME 2 and ME 4 clip-on microphones

- To reduce level variations to a minimum when the user turns his or her head away from the microphone, attach the microphone as centrally as possible.
- To protect the microphone against excessive sweat/moisture, avoid direct skin contact.
- Attach the microphone carefully and conduct the cable so that noise due to friction is avoided.
- Always use the ME 4 directional microphone with a windshield and direct the microphone towards the sound source (e.g. mouth).

### ... for the ME 3 headmic

- Always use the microphone with a popshield and position the microphone at the corner of the mouth.
- You can vary the bass reproduction by increasing/decreasing the talking distance.
- Make sure that the sound inlet is directed towards the mouth. The sound inlet is marked with a little dot.

### ... for the SK 300 G2 bodypack transmitter

- Make sure that the antenna and the microphone cable do not cross.
- The antenna should hang freely and be at least 1 cm away from the body. The antenna must not be in direct contact with the skin.
- For best results, make sure that the transmitter sensitivity is correctly adjusted.

### ... for the SKM 300 G2 radiomicrophone

- Hold the SKM 300 G2 in the middle of the microphone body. Holding it close to the sound inlet basket will influence the microphone's pick-up pattern, holding it at the lower part of the body will reduce the transmitter's range.
- You can vary the bass reproduction by increasing/decreasing the talking distance.
- For best results, make sure that the transmitter sensitivity is correctly adjusted.

### ... for optimum reception

- Transmission range depends to a large extent on location and can vary from about 10 m to about 150 m. There should be a "free line of sight" between transmitting and receiving antennas.
- If, with the EM 300 G2 receiver, reception conditions are unfavourable, you should use two remote antennas which are connected via antenna cable.
- To avoid overmodulating the receiver, observe a minimum distance of 5 m between transmitting and receiving antennas.
- Observe a minimum distance of 50 cm between receiving antennas and metal objects (such as cross members or reinforced-concrete walls).

### ... for multi-channel operation

- For multi-channel operation, you can only use the channels in a channel bank. Each of the channel banks "1" to "8" accommodates eight factory-preset frequencies which are intermodulation-free. For alternative frequency combinations, please refer to the enclosed frequency table. The freely selectable frequencies can be selected via the "TUNE" menu and can be stored in the channel bank "U".
- When using several transmitters simultaneously, interference can be avoided by maintaining a minimum distance of 20 cm between two transmitters.
- Use special accessories for multi-channel applications (see "Accessories" on page 89).

## Care and maintenance

Use a slightly damp cloth to clean the units from time to time.

### Note:

Do not use any cleansing agents or solvents.

To clean the SKM 300 G2's sound inlet basket, proceed as follows:

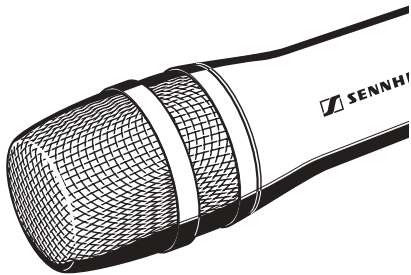

- ▶ Unscrew the sound inlet basket (turn counterclockwise) and remove it.
- ▶ Remove the foam insert.
- ▶ Use a slightly damp cloth to clean the sound inlet basket from the inside and outside.
- ▶ Reinsert the foam insert.
- ▶ Replace the sound inlet basket on the SKM 300 G2 and screw it tight (taking care not to loose the colored identification ring).

# Additional information

## HDX noise reduction

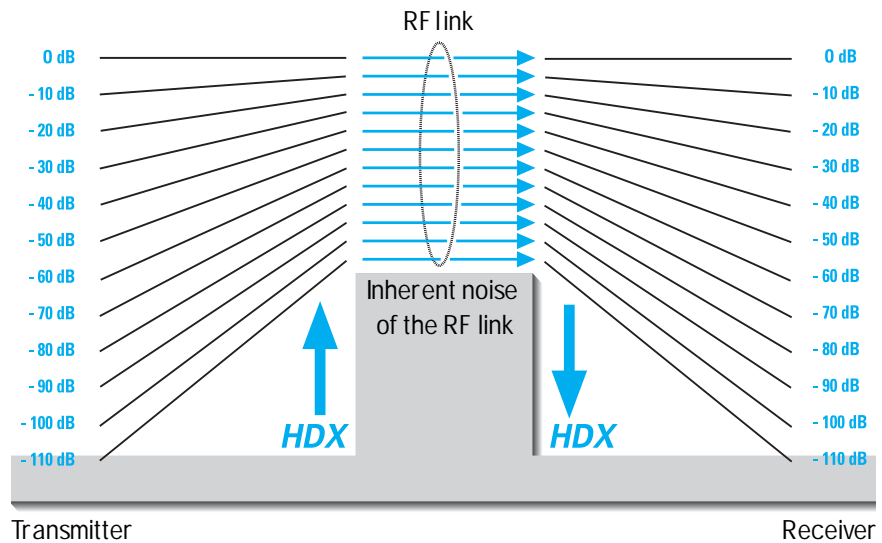

Progress you can hear:

The evolution wireless G2 series is equipped with HDX, the Sennheiser noise reduction system that reduces RF interference. It increases the signal-to-noise ratio in wireless audio transmission to more than 110 dB.

HDX is a wideband compander system which compresses the audio signal in the transmitter in a 2:1 ratio (related to dB) to lift it above the inherent noise floor of the RF link. A 110 dB dynamic range signal is thus transmitted with an effective dynamic range of only 55 dB, which is above the 60 dB noise floor of the RF link. In the receiver the signal is expanded in an identical and opposite way in a 1:2 ratio to restore the original signal, at the same time reducing the RF noise to below the noise floor of the receiver.

HDX has been specially developed for high quality radiomicrophone systems.

### Note:

Only transmitters and receivers that are equipped with HDX can work correctly with each other. If non HDX equipment was mixed with HDX, the dynamic range would be drastically reduced and the transmission would sound blunt and flat. HDX is permanently active and cannot be switched off.

## Wireless transmission systems

With the ew 300 G2 series, Sennheiser puts an end to cable tangles and enables complete freedom of movement. The systems operate exclusively in the UHF band. UHF transmission is extremely reliable and is far less prone to interference than the overcrowded VHF band – harmonics from mains units, fluorescent tubes, refrigerators, computers, etc. are virtually eliminated. Also indoor propagation of UHF radio waves is better than VHF so that the RF power can be kept low – this is also an advantage when using multi-channel systems. Finally, UHF frequency ranges are being approved all over the world for radiomicrophone usage – in some countries licence-free.

There are two transmitter versions: The hand-held transmitter is a complete radiomicrophone in a single unit, the bodypack transmitter can accept a wide range of inputs including: omni-directional or cardioid clip-on microphones, head-worn microphone, guitar/instrument direct input and auxiliary units via the optional CL 2 line input cable.

Correct adjustment of transmitter sensitivity is vital. Too high and you get overmodulation and distortion, too low and you get undermodulation and a

noisy signal. Please set the sensitivity correctly for the microphone/usage and check it before every performance to ensure best operation.

Sennheiser miniature clip-on microphones can be attached in various ways: they can, for example, be attached to the hairline or to clothing (e.g. tie or lapel). However it is fixed, please make sure that the microphone is protected against sweat/moisture and make-up.

## Squelch

### Pilot tone squelch

The transmitter adds a pilot tone to the audio signal. The receiver checks incoming audio signals to see if the pilot tone is present. In the absence of the signal, the receiver's audio output will remain muted, even if a strong RF signal is present.

This prevents strong interfering signals from causing hissing noise in the receiver when the transmitter is switched off.

In order to benefit from this feature, the pilot tone function must be activated on both the transmitter and the receiver. The pilot tone function is factory-preset to "ON" (= activated).

### Field strength-dependent squelch

Depending on the strength of the received RF signal, the receiver's audio output is opened or muted. Via the "Squelch" menu of the receiver, the squelch threshold can be adjusted in three steps (Low, Mid, High).

## Diversity reception

The EM 300 G2 receiver operates on the "true diversity" principle:

A receiving antenna receives not only the electromagnetic waves which reach it by a direct path, but also the reflections of these waves which are created in the room by walls, windows, ceilings and fittings. When these waves are superimposed, destructive interference occurs, which can also be called "field strength gaps". Repositioning the receiving antenna can bring a solution. With mobile transmitters, however (which all radiomicrophones are), the "field strength gap" will then occur with a different transmitter position. These "field strength gaps" can only be eliminated with true diversity receivers.

In true diversity, instead of one antenna and one receiver there are now two antennas and two receiver sections. The antennas are spatially separated. By means of a comparison circuit, the receiver section with the strongest RF signal is always switched to the common AF output. The risk of the occurrence of "field strength gaps" in both antennas at the same time is virtually nonexistent.

The receiver display panel shows the active diversity section (I or II) ⑥.

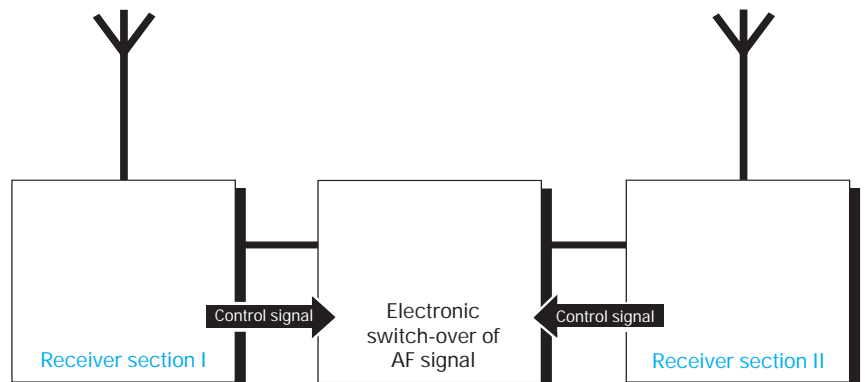
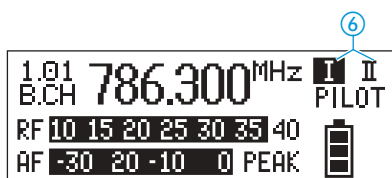

# Specifications

## System

<b>RF characteristics</b>	
Modulation	wideband FM
Frequency ranges	518–554, 626–662, 740–776, 786–822, 830–866 MHz
Transmission/receiving frequencies	8 channel banks with 8 factory-preset channels each 1 channel bank with 8 freely selectable channels (1440 frequencies, tunable in steps of 25 kHz)
Switching bandwidth	36 MHz
Nominal/peak deviation	$\pm 24$ kHz/ $\pm 48$ kHz
Frequency stability	$\leq \pm 15$ ppm
<b>AF characteristics</b>	
Noise reduction system	Sennheiser HDX
AF frequency response	40–18,000 Hz
S/N ratio (at 1 mV and peak deviation)	$\geq 112$ dB(A)
THD (at nominal deviation and 1 kHz)	$\leq 0.9$ %
<b>General data</b>	
Temperature range	$-10$ °C to $+55$ °C
Dimensions of carrying case [mm]	380 x 370 x 70
Weight of carrying case	approx. 3100 g

## Receiver

<b>RF characteristics</b>	<b>EM 300 G2</b>
Receiver principle	true diversity
Sensitivity (with HDX, peak deviation)	$< 2.5$ $\mu$ V at 52 dB <sub>A,rms</sub> S/N ratio
Adjacent channel rejection	$\geq 68$ dB
Intermodulation attenuation	$\geq 68$ dB
Blocking	$\geq 72$ dB
Squelch	4 steps: Off Low: 5 dB $\mu$ V Mid: 15 dB $\mu$ V High: 25 dB $\mu$ V
Pilot tone squelch	can be switched off
Antenna inputs	2 BNC sockets
<b>AF characteristics</b>	
AF output voltage (at peak deviation 1 kHz <sub>AF</sub> )	1/4" (6.3 mm) jack socket (unbalanced): +12 dB <sub>u</sub> XLR socket (balanced): +18 dB <sub>u</sub>
<b>Overall device</b>	
Power supply	10.5 – 16 V DC, nominal voltage 12 V DC
Power consumption	approx. 200 mA
Dimensions [mm]	212 x 145 x 38
Weight	approx. 1100 g



## Transmitters

		SK 300 G2	SKM 300 G2
RF characteristics			
RF output power at 50 Ω		typ. 30 mW	
AF characteristics			
Max. input voltage (at peak deviation)	Microphone	1.8 V <sub>rms</sub> unbalanced	–
	Line	2.4 V <sub>rms</sub>	–
Input impedance	Microphone	10 kΩ, unbalanced	–
	Line	1 MΩ	–
Overall device			
Power supply		2 AA size batteries, 1.5 V	
Nominal voltage		2.4 V	
Max. power consumption at nominal voltage		≤ 170 mA	≤ 170 mA
Power consumption with switched-off transmitter		≤ 250 μA	≤ 250 μA
Operating time (with batteries)		≥ 8 h	≥ 8 h
Operating time (with BA 2015 accupack)		≥ 8 h	≥ 8 h
Dimensions [mm]		82 x 64 x 24	∅ 50 x 225
Weight (incl. batteries)		approx. 158 g	approx. 450 g

## Microphones

	ME 2	ME 3	ME 4
Transducer principle	condenser	condenser	condenser
Sensitivity	20 mV/Pa	1.6 mV/Pa	40 mV/Pa
Pick-up pattern	omni-directional	super-cardioid	cardioid
Max. SPL	130 dB SPL	150 dB SPL	120 dB SPL

## Microphone heads

	MD 835	MD 845	ME 865
Transducer principle	dynamic	dynamic	condenser
Sensitivity	1.5 mV/Pa	1 mV/Pa	3 mV/Pa
Pick-up pattern	cardioid	super-cardioid	super-cardioid
Max. SPL	150 dB SPL	154 dB SPL	144 dB SPL
Color of identification ring	green	blue	red

## connector assignment

EM 300 G2:

1/4" (6.3 mm) stereo jack plug, unbalanced

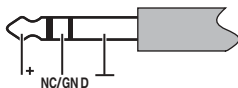

EM 300 G2:

1/4" (6.3 mm) mono jack plug, unbalanced

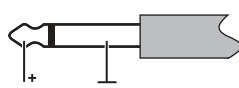

EM 300 G2:

XLR-3F connector, balanced

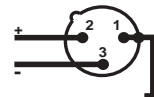

M 300 G2:

DC connector for power supply



SK 300 G2:

3.5 mm jack plug

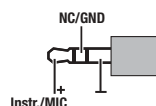

# Polar diagrams and frequency response curves of microphones/microphone heads

## Polar diagrams of microphones/microphone heads

MD 835

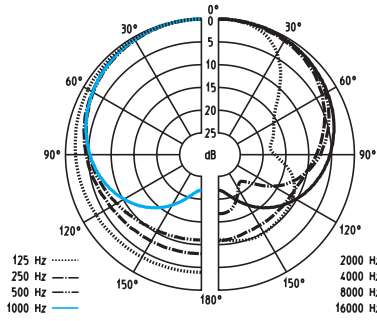

ME 865

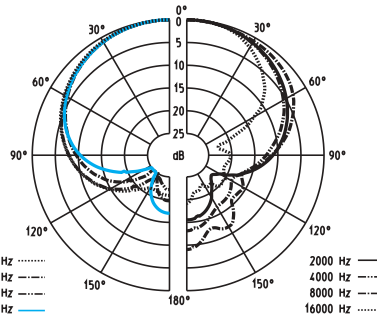

ME 3

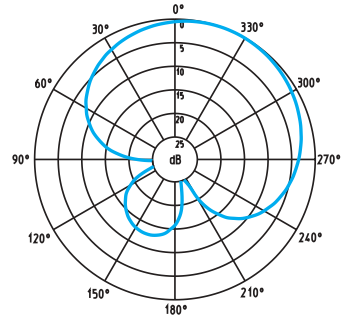

MD 845

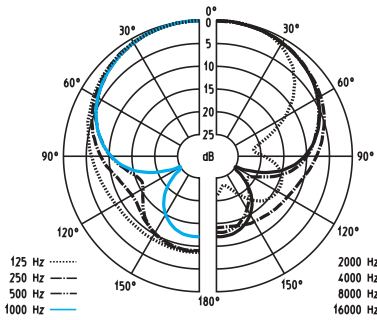

ME 4

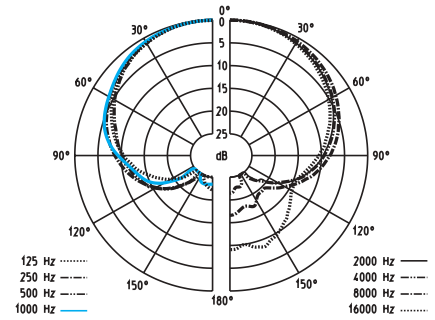

## Frequency response curves of microphones/microphone heads

MD 835

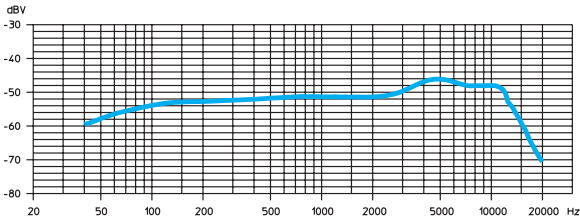

ME 2

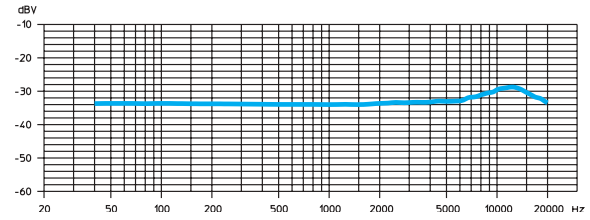

MD 845

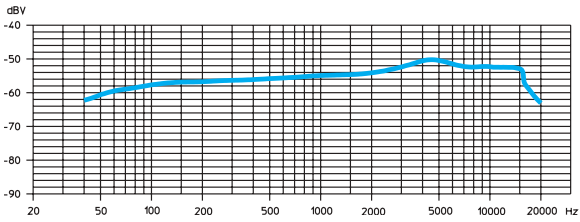

ME 3

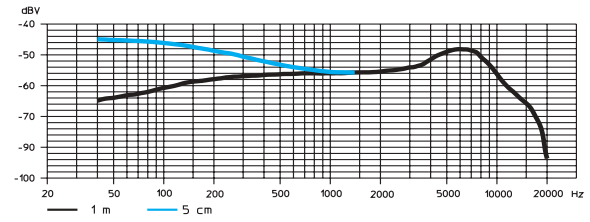

ME 865

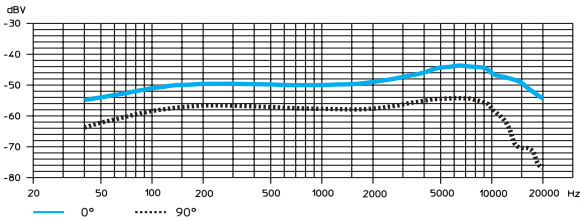

ME 4

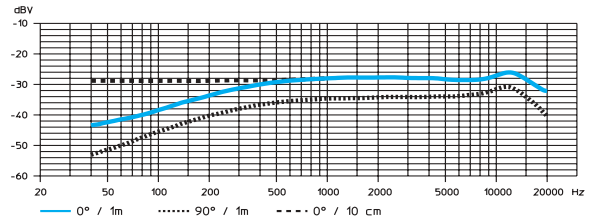

# Accessories

- MD 835** Microphone head for SKM 300 G2 (green identification ring), dynamic, cardioid
- MD 845** Microphone head for SKM 300 G2 (blue identification ring), dynamic, super-cardioid
- ME 865** Microphone head for SKM 300 G2 (red identification ring), condenser, super-cardioid
- MZW 1** Wind- and popshield for SKM 300 G2
- MZQ 1** Microphone clamp for SKM 300 G2
- ME 2** Clip-on microphone for SK 300 G2, condenser, omni-directional
- ME 4** Clip-on microphone for SK 300 G2, condenser, cardioid
- ME 3** Headmic for SK 300 G2, condenser, super-cardioid
- CI 1** Instrument cable for SK 300 G2, with ¼" (6.3 mm) jack plug
- CL 2** Line input cable for SK 300 G2, with XLR-3F connector
- GA 2** 19" rack adapter
- AM 2** Antenna mount for mounting antennas to the front of the GA 2
- A 1031-U** UHF antenna, passive, omni-directional, can be mounted onto a stand
- AB 2-A** UHF antenna booster, 10 dB gain powered via ASP 2/NT1      518–554 MHz
- AB 2-B**      626–662 MHz
- AB 2-C**      740–776 MHz
- AB 2-D**      786–822 MHz
- AB 2-E**      830–866 MHz
- GZL 1019-A1 / 5 / 10** Antenna cable with BNC connectors      1 m / 5 m / 10 m
- ASP 2** Antenna splitter, 2 x 1:4, passive, for connecting eight EM 300 G2 to two A 1031-U/AB 2
- NT 1** Mains unit for ASP 2
- DC 2** DC power adapter, for external 12 V DC powering of SK 300 G2 (instead of two AA size batteries)
- BA 2015** Accupack for SK 300 G2 and SKM 300 G2
- L 2015** Charger for BA 2015 accupack
- CC 2** Carrying case for ew 300 G2 system
- KEN** 8 color-coded identification caps for SKM 300 G2

## Garantiebestimmungen

Wir übernehmen für das von Ihnen gekaufte Produkt eine Garantie von 24 Monaten. Ausgenommen hiervon sind dem Produkt beigelegte Zubehörartikel, Akkus und Batterien; denn diese Produkte haben wegen ihrer Beschaffenheit eine kürzere Lebensdauer, die zudem im Einzelfall konkret von Ihrer Nutzungsintensität abhängt.

Die Garantiezeit beginnt ab Kaufdatum. Zum Nachweis heben Sie bitte unbedingt den Kaufbeleg auf. Ohne diese Nachweise, die der zuständige Sennheiser-Service-Partner prüft, werden Reparaturen grundsätzlich kostenpflichtig ausgeführt.

Die Garantieleistungen bestehen nach unserer Wahl in der unentgeltlichen Beseitigung von Material- oder Herstellungsfehlern durch Reparatur, Tausch von Teilen oder des kompletten Geräts. Von der Garantie ausgenommen sind Mängel durch unsachgemäßen Gebrauch (z.B. Bedienungsfehler, mechanische Beschädigungen, falsche Betriebsspannung), Verschleiß, aufgrund höherer Gewalt und solche Mängel, die Ihnen beim Kauf bereits bekannt sind. Der Garantieanspruch erlischt bei Eingriffen in das Produkt durch nicht autorisierte Personen oder Werkstätten.

Im Garantiefall senden Sie das Gerät inklusive Zubehör und Kaufbeleg an den für Sie zuständigen Service-Partner. Zur Vermeidung von Transportschäden sollte möglichst die Original-Verpackung verwendet werden.

Ihre gesetzlichen Mängelansprüche aus dem Kaufvertrag gegen den Verkäufer werden durch diese Garantie nicht eingeschränkt. Die Garantie kann weltweit in allen Ländern – außer in den USA – in Anspruch genommen werden, in denen das jeweils nationale Recht unseren Garantiebestimmungen nicht entgegensteht.

## Warranty regulations

The guarantee period for this Sennheiser product is 24 months from the date of purchase. Excluded are accessory items, rechargeable or disposable batteries that are delivered with the product; due to their characteristics these products have a shorter service life that is principally dependent on the individual frequency of use.

The guarantee period starts from the date of original purchase. For this reason, we recommend that the sales receipt be retained as proof of purchase. Without this proof (which is checked by the responsible Sennheiser service partner) you will not be reimbursed for any repairs that are carried out.

Depending on our choice, guarantee service comprises, free of charge, the removal of material and manufacturing defects through repair or replacement of either individual parts or the entire device. Inappropriate usage (e.g. operating faults, mechanical damages, incorrect operating voltage), wear and tear, force majeure and defects which were known at the time of purchase are excluded from guarantee claims. The guarantee is void if the product is manipulated by non-authorized persons or repair stations.

In the case of a claim under the terms of this guarantee, send the device, including accessories and sales receipt, to the responsible service partner. To minimise the risk of transport damage, we recommend that the original packaging is used. Your legal rights against the seller, resulting from the contract of sale, are not affected by this guarantee.

The guarantee can be claimed in all countries outside the U.S. provided that no national law limits our terms of guarantee.

## Conditions de garantie

La période de garantie pour ce produit Sennheiser est de 24 mois à compter de la date d'achat. Sont exclues, les batteries rechargeables ou jetables livrées avec le produit. En raison de leurs caractéristiques ces produits ont une durée de vie plus courte liée principalement à la fréquence d'utilisation.

La période de garantie commence à la date de l'achat. Pour cette raison, nous vous recommandons de conserver votre facture comme preuve d'achat. Sans cette preuve -qui est vérifiée par Sennheiser -aucune prise en compte de la garantie ne pourra être retenue.

La garantie comprend, gratuitement, la remise en état de fonctionnement du matériel par la réparation ou le remplacement des pièces défectueuses ou dans le cas où la réparation n'est pas possible, par échange du matériel. L'utilisation inadéquate (mauvaise utilisation, dégâts mécaniques, tension électrique incorrecte), sont exclus de la garantie. La garantie est invalidée en cas d'intervention par des personnes non-autorisées ou des stations de réparation non agréées.

Pour faire jouer la garantie, retournez l'appareil et ses accessoires, accompagnés de la facture d'achat, à votre distributeur agréé. Pour éviter des dégâts durant le transport il est recommandé d'utiliser l'emballage d'origine.

Votre droit légal de recours contre le vendeur n'est pas limité par cette garantie. La garantie peut être revendiquée dans tous les pays à l'extérieur des Etats-Unis à condition qu'aucune loi nationale n'en invalide les termes.

## Garanzia prodotti

La Sennheiser garantisce il prodotto da voi acquistato per una durata di 24 mesi. Sono esclusi da questa garanzia gli accessori in dotazione con il prodotto, gli accumulatori e le batterie perché questi prodotti hanno un ciclo di vita più breve che dipende molto dall'intensità d'utilizzo. Il periodo di garanzia decorre dalla data dell'acquisto. Fa fede il documento d'acquisto valido agli effetti fiscali che deve essere conservato. Senza questo documento, che deve essere controllato dal centro di servizio Sennheiser, qualsiasi riparazione viene effettuata solo dietro pagamento.

Le prestazioni gratuite di garanzia possono consistere nell'eliminazione del difetto di materiale o fabbricazione attraverso la riparazione, la sostituzione di parti o del completo apparecchio, secondo nostro insindacabile giudizio. Sono esclusi dalla garanzia i guasti derivanti da cattivo uso dell'apparecchio (p.e. mancata osservanza delle istruzioni all'uso, danneggiamenti meccanici, tensione d'alimentazione errata), dall'usura, da cause di forza maggiore o da malfunzionamenti già a vostra conoscenza al momento dell'acquisto. La garanzia decade inoltre in caso di manomissioni effettuate da persone o centri di manutenzione non autorizzate. In caso di un reclamo nel periodo di garanzia vogliate inviare l'apparecchio insieme agli accessori in dotazione e il documento d'acquisto al vostro centro servizio autorizzato.

Per evitare danni di trasporto consigliamo di utilizzare l'imballo originale. In caso di guasto questa garanzia non pregiudica i vostri diritti derivanti dal contratto d'acquisto verso il negoziante dove è stato acquistato il prodotto.

La garanzia è estesa a tutti i paesi del mondo, tranne agli Stati Uniti, e può essere applicata se la legislazione nazionale lo permette.

## Declaración de garantía

El periodo de garantía para este producto es de 24 meses desde la fecha de compra. Quedan excluidos los accesorios adjuntos al producto, acumuladores y baterías dado que, debido a sus características, la vida útil de dichos productos es mucho más corta y, en determinados casos, depende concretamente de la intensidad de utilización. El periodo de garantía comienza a partir de la fecha de compra. Por eso le recomendamos que guarde el recibo como prueba de compra. Sin dicha prueba, que será verificada por el respectivo concesionario Sennheiser, cualquier reparación que sea necesaria será efectuada contra factura.

Según determine el fabricante, las prestaciones de garantía consistirán en la eliminación gratuita de defectos de materiales o fabricación, por medio de reparación, sustitución de piezas, o bien en la sustitución del aparato completo. La garantía no tendrá validez en caso de defectos ocasionados por un uso inadecuado (tales como manejo incorrecto daños mecánicos, tensión de servicio equivocada), desgaste, o bien efectos de fuerza mayor, y desperfectos ya detectados en el momento de adquirir el producto. La garantía carecerá de validez si el defecto se debe a modificaciones y reparaciones hechas en el producto por personas o talleres no autorizados.

En caso de reclamación sírvase remitir el aparato incluyendo los accesorios y la factura al concesionario Sennheiser encargado de su zona. A fin de evitar daños durante el transporte se aconseja emplear el envase original. Las pretensiones legales por defectos y emanadas del contrato de compraventa frente al vendedor, no quedan limitadas por esta garantía.

La garantía está disponible en todos los países a excepción de EE.UU., siempre que la legislación nacional aplicable no sea contraria a nuestras determinaciones de garantía.

## Garantiebepalingen

Wij hanteren voor onze producten een garantietermijn gedurende een periode van 24 maanden. Uitgezonderd hiervan zijn accessoires, accu's en batterijen die aan het product toegevoegd zijn; op grond van hun leeftijd beschikken deze producten over een kortere levensduur die van geval tot geval van hun gebruikintensiteit afhangt.

De garantietermijn begint vanaf de aankoopdatum. Daarom dient u de originele aankoopbon goed te bewaren. Zonder dit bewijs, dat door de Sennheiser servicepartner wordt gecontroleerd, worden reparaties in principe tegen kostenvergoeding uitgevoerd.

De garantievergoedingen bestaan naar onze keuze uit het kosteloze verhelpen van materiaal of fabricagefouten op basis van vervanging (afzonderlijke onderdelen of het complete apparaat) danwel reparatie. De garantie vervalt bij verkeerd gebruik of onachtzaamheid.

(bijv. bedieningsfouten, mechanische beschadigingen, onjuiste bedrijfsspanning), slijtage gevallen van force majeure of gebreken welke u reeds bij de aankoop heeft gekend. Het recht op garantie vervalt indien reparaties of wijzigingen zijn uitgevoerd door niet bevoegde personen of werkplaatsen. Indien u aanspraak maakt op garantie dient u het apparaat, inclusief accessoires en aankoopbon, franco aan de bevoegde servicepartner toe te zenden. Om beschadigingen gedurende het transport te voorkomen adviseren wij de originele verpakking te gebruiken.

Uw wettelijke garantieclaims tegenover de verkoper worden door deze garantie niet beperkt. De garantie kan wereldwijd in alle landen buiten de VS worden opgevorderd waarin de geldende nationale wetten niet in tegen.



Sennheiser electronic GmbH & Co. KG  
30900 Wedemark, Germany  
Phone +49 (5130) 600 0  
Fax +49 (5130) 600 300  
[www.sennheiser.com](http://www.sennheiser.com)