

# SHURE

LEGENDARY  
PERFORMANCE™

# AXIENT



## AXT200 Handheld Frequency Diversity Transmitter

©2011 Shure Incorporated  
27B15018 (Rev. 2)



CE

Printed in USA

**WARNING:** This product contains a chemical known to the State of California to cause cancer and birth defects or other reproductive harm.



**WARNING**

- Battery packs may explode or release toxic materials. Risk of fire or burns. Do not open, crush, modify, disassemble, heat above 140°F (60°C), or incinerate
- Follow instructions from manufacturer
- Never put batteries in mouth. If swallowed, contact your physician or local poison control center
- Do not short circuit; may cause burns or catch fire
- Do not charge or use battery packs with other than specified Shure products
- Dispose of battery packs properly. Check with local vendor for proper disposal of used battery packs

## AXT200 Handheld Transmitter

The AXT200 Handheld Frequency Diversity Transmitter is a rechargeable, remotely controllable handheld transmitter with Frequency Diversity for seamless, uninterrupted audio in even the most challenging RF environments. In addition to Frequency Diversity, the AXT200 delivers ultra-linear RF performance for more channels on-air and superb audio quality. Advanced power management supports extended battery life and highly accurate status metering. ShowLink™ Remote Control enables comprehensive real-time remote control of all transmitter parameters, including real-time frequency adjustments.

### Features

- Frequency Diversity enables simultaneous transmission on two independent frequencies to ensure seamless, uninterrupted audio for mission-critical transmitters. Single carrier mode is available if Frequency Diversity is not required.
- Ultra-linear RF performance enables more channels on-air
- IR Sync function automatically tunes transmitter to the receiver frequency
- Comprehensive real-time remote control of all transmitter parameters when a Linked transmitter is within range of a ShowLink Access Point
- Shure lithium-ion rechargeable battery delivers up to 9 hours of runtime from a single charge
- Advanced control menu to adjust frequency and audio settings from the transmitter
- 42 dB of adjustable gain for optimal audio quality
- Lockable user interface prevents accidental or inadvertent changes to controls once settings are made

## Transmitter Overview

### ① Microphone Cartridge

Interchangeable with a variety of Shure cartridges

### ② LCD Display

View menu screens and settings. Momentarily press power button to activate backlight.

### ③ Infrared (IR) Port

Use for automated transmitter programming. Links transmitter to AXT400 Receiver.

### ④ Shure Rechargeable Lithium-ion Battery

Delivers up to 9 hours of runtime from a single charge

### ⑤ Locking Ring

Secures the battery and protects the control buttons

### ⑥ Dual-Band Antenna

Covers UHF tuning range and 2.4 GHz ShowLink signal

### ⑦ Arrow Buttons

Use to scroll through menu screens and to change parameter values

### ⑧ Set Button

Enables parameter editing. After editing is complete, press to save changes and return to the main menu screen.

### ⑨ Power Button

Hold for 1 second to turn the transmitter on. To power off, press and hold for 2 seconds until the display reads **Powering Off**. When editing parameters, acts as an exit button to cancel changes and return to a previous parameter or to the main menu screen.

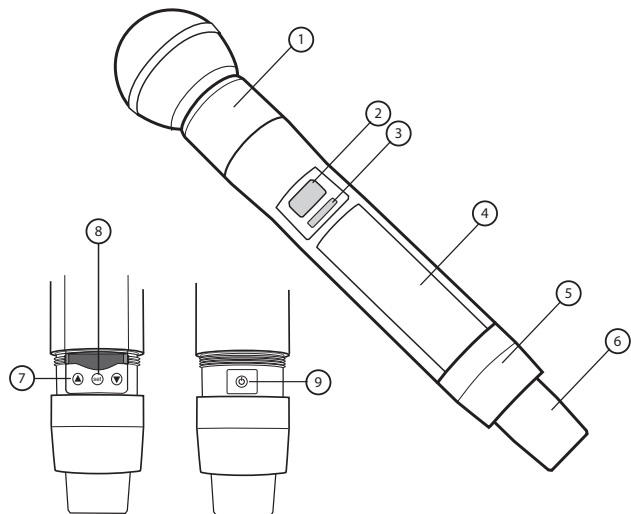

## Included Components

Handheld rechargeable lithium-ion battery (2)	AXT920 or AXT920SL
Transmitter carrying case	95A15475
Zipper bag	26A14
Microphone stand adaptor	WA371

### Choice of (1) of the following Shure microphone cartridges:

<b>SM58</b> (RPW112)	<b>KSM9 Champagne</b> (RPW180)
<b>BETA 87C</b> (RPW122)	<b>BETA 87A</b> (RPW120)
<b>BETA 58A</b> (RPW 118)	<b>KSM9 Black</b> (RPW184)

## Optional Accessories

Handheld rechargeable lithium-ion battery	AXT920 or AXT920SL
Portable handheld charging station	AXT904
1-AA battery carrier for AXT200 handheld transmitter	AXT921
Microphone stand adaptor	WA371

### Optional Shure microphone cartridges:

<b>SM58</b> (RPW112)	<b>BETA 87C</b> (RPW122)	<b>VP68</b> (RPW124)
<b>BETA 87A</b> (RPW120)	<b>SM87A</b> (RPW116)	<b>KSM9 Black</b> (RPW184)
<b>SM86</b> (RPW114)	<b>KSM9 Champagne</b> (RPW180)	<b>BETA 58A</b> (RPW118)

## Batteries

The transmitter is powered by a Shure lithium-ion rechargeable battery.

**Caution:** Turn off the transmitter before changing batteries.

**Note:** Refer to your battery charger manual for charging instructions.

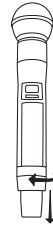

Unscrew the locking ring

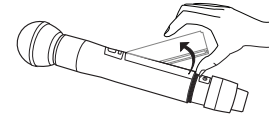

Remove the battery

## Battery Runtime

Battery runtime varies according to the transmitter's operating mode. High power settings or operating in Frequency Diversity mode will reduce battery runtime.

Remaining battery runtime is shown on the display in hours and minutes (accurate to within 15 minutes).

The times shown in the table represent a battery with a minimum of 5 charge cycles, fully charged, at 100% health.

RF Power (mW)	Mode	Runtime ShowLink Enabled (hours/minutes)	Runtime Without ShowLink (hours/minutes)
10	Single Carrier	9:05	10:00
	Frequency Diversity	6:15	6:45
50	Single Carrier	6:45	7:15
	Frequency Diversity	4:20	4:40

## Main Menu Screen

The main menu screen displays the following transmitter parameters:

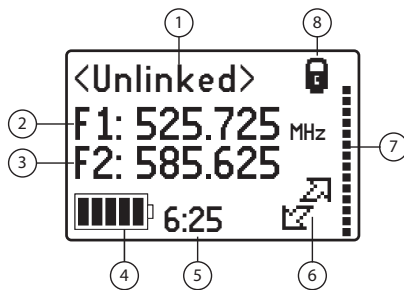

### ① Link Status

- **Linked** : Displays Linked receiver channel name
- **Unlinked** : Not Linked to a receiver

### ② Frequency 1

Tuned frequency 1 of the transmitter

### ③ Frequency 2

Tuned frequency 2 of the transmitter (Frequency Diversity mode enabled)

### ④ Battery Charge Indicator

5-segment icon visually indicates battery life

### ⑤ Remaining Battery Life

Displays remaining battery life in hours and minutes

### ⑥ ShowLink Icon

Indicates remote control of transmitter via ShowLink is possible

### ⑦ Audio Meter

Indicates the audio signal level

### ⑧ Control Lock Icon

Displayed when buttons are locked

## Locking the Buttons

Lock the buttons of the transmitter to prevent accidental or unauthorized parameter changes.

Press and hold the ▼ and ▲ buttons for 2 seconds to lock. Repeat to unlock.

## Power-on RF mute

Power-on RF mute prevents transmission of audio when powering on the transmitter.

With the transmitter turned off, press and hold both the ▼ button and the **SET** button, and then press and hold the **Power** button.

After power-on, an **RF Muted** message indicates that the transmitter is in RF Mute mode.

**Note:** RF Mute mode persists through power cycles of the transmitter.

## Linking a Transmitter using IR Sync

The IR Sync function forms a Link and sets the frequency between the transmitter and an AXT400 Receiver.

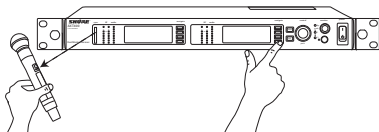

1. Access the IR Sync function in the AXT400 receiver menu: **Tx**

2. Align the IR Sync ports of the transmitter and the receiver. The red IR Sync LED on the receiver IR port will illuminate to indicate correct alignment. Press **Sync**.

3. The receiver display indicates if the IR Sync is successful. Check the transmitter alignment and select **Retry** if a failure occurs.

4. The transmitter device ID will be shown in the receiver Tx menu and the receiver channel name and frequency will be shown on the transmitter display, indicating a successful IR sync.

## AXT200 Frequency Diversity Mode

Operating an AXT200 in Frequency Diversity mode with an AXT400 Receiver enables simultaneous transmission of audio on 2 independent frequencies.

1. From the AXT400 menu: **Radio > Options > Diversity**

2. Use the control wheel to set the mode to **FD-Handheld**.

3. Perform an IR Sync to Link the transmitter to the receiver.

---

## Parameter Menus

Use the arrow buttons to access the following parameter menus.

### Group and Channel

A group is a set of compatible frequencies. A single frequency within a group is a channel.

- G:**  
Change the group
- Ch:**  
Change the channel

### F1: and F2: Frequency

Use the set and arrow keys to change the frequency in 25 KHz increments.

### Disable F2

When in frequency diversity mode, the second frequency can be disabled from the **F2**: frequency menu or the **F2**: group and channel menu.

- F2: ON**  
Enable F2
- F2: OFF**  
Disable F2

### Gain

Sets the input sensitivity level (gain). Gain range is -10 to +32 dB in 1 dB steps.

### RF Mute

Disables the RF carrier signal, which mutes transmission of audio.

- TX On:**  
RF signal enabled
- TX Off:**  
RF signal disabled

### Firmware

Displays the installed firmware version.

### Device ID

Identifies the transmitter on a linked receiver or in WWB software.

- ID length can be up to 8 characters
- Use arrow buttons to scroll through characters
- Use **set** button to save and move to the next character

### AA Type

This setting ensures accurate battery metering when using the optional AA battery carrier. Set the battery type to **Alkaline**, **NiMH**, or **Lithium**.

**Note:** Menu not displayed unless an AA battery carrier is installed.

### ShowLink Test

Activates the ShowLink test 5-bar display. Measures the remote control range of a ShowLink Access Point.

- 5 bars indicate the center of the coverage area
- 1 bar indicates the outer boundary of the coverage area
- If bars are not displayed, ShowLink control is not available

### Unlink

Ends the Link relationship between transmitter and receiver.

- YES:**  
Ends the Link between transmitter and receiver.
- NO:**  
Preserves the Link between transmitter and receiver.

**Note:** When a transmitter is unlinked, the channel name reverts to **Unlinked**.

### RFPWR

Sets RF power level. Access this menu by pressing and holding the **set** button and then pressing the **▼** button.

Use lower power settings to conserve battery life and to prevent RF overload at the receiver.

**Note:** A password is required in some regions.

### PCB Serial Number

Displays the serial number of the printed circuit board (PCB) installed in the unit.

1. Enter the **RFPWR** menu by pressing and holding the **set** button, and then pressing the **▼** button.
2. Press the **▲** button to access the serial number.
3. Momentarily press the power button to return to the home menu screen.

---

## Troubleshooting

### No ShowLink Alert

This alert appears when frequency is edited on a linked transmitter that is beyond the range of an active ShowLink access point. Choose **OK** to unlink the transmitter and complete the frequency change, or **Cancel** to return to the home screen.

### Input Overload

The **Input Overload** message indicates an excessive signal level at the transmitter input. To prevent overload, reduce the gain setting.

### Deeply Discharged Batteries

Deep discharge occurs when a battery is discharged to less than 3.0 volts. The battery chargers have a recovery mode designed to restore charge to a deeply discharged battery.

When the charger detects a deeply discharged battery, it automatically enters recovery mode which supplies reduced current to the battery for up to 30 minutes.

If recovery is successful, the charger will exit recovery mode and charge the battery to capacity. If the battery cannot be recharged, charging stops and the battery must be replaced.

---

## Firmware Updates

Firmware is embedded software used to control features and the user interface. Periodically, new versions of firmware are available for download from [www.shure.com/wwb](http://www.shure.com/wwb) to incorporate additional features and enhancements. New versions of the firmware can be downloaded to AXT400 Receiver using the Firmware Update Manager tool available in WWB6 software and installed on the transmitter using the infrared ports on the transmitter and receiver.

To access the AXT400 receiver firmware update menu: **Tx > IR Presets > FW Update**

# Specifications- AXT200 Handheld Transmitter

<b>RF Carrier Frequency Range</b>	470–814 MHz Note: varies by region
<b>Working Range</b>	<b>Under typical conditions:</b> 150 m (500 ft) <b>Line of Sight, outdoors for a single system:</b> 500 m (1600 ft) Note: Actual range depends on RF signal absorption, reflection and interference.
<b>Audio Frequency Response</b>	40 Hz – 18 kHz (+1, -3 dB) Note: Dependent on microphone type
<b>RF Tuning Step Size</b>	25 kHz
<b>Modulation</b> 45 kHz max. deviation	FM, Audio Reference Companding with pre- and de-emphasis
<b>Dynamic Range</b>	>113 dB, A-weighted (referenced at 0 dB setting on transmitter)
<b>Total Harmonic Distortion</b> 45 kHz max. deviation	<0.3%, A-weighted, typical
<b>System Audio Polarity</b>	Positive pressure on microphone diaphragm (or positive voltage applied to tip of WA302 phone plug) produces positive voltage on pin 2 (with respect to pin 3 of low-impedance output) and the tip of the high impedance 1/4-inch output.

## AXT200

<b>Gain Adjustment Range</b>	-10 to +32 dB (in 1 dB steps)
<b>Battery Type</b>	Shure AXT920/920SL (Rechargeable Li-Ion)
<b>Battery Life</b>	Up to 9 hours (low power mode, Single Carrier Mode)
<b>Dimensions</b>	261 mm x 37 mm (10.3 in. x 2.6 in.) L x Dia.
<b>Weight</b>	395 g (13.9 oz.), with batteries
<b>Housing</b>	Machined aluminum
<b>Operating Temperature Range</b>	-18°C (0°F) to 63°C (145°F) Note: Battery characteristics may limit this range.
<b>Storage Temperature Range</b>	-29°C (-20°F) to 74°C (165°F) Note: Battery characteristics may limit this range.

## Audio Input

<b>Configuration</b>	Unbalanced		
<b>Impedance</b>	>30 kΩ		
<b>Maximum Input Level</b> 1 kHz at 1% THD	<b>gain position:</b>	<b>-10 to +11 dB:</b>	5.5 dBu
		<b>+12 to +32 dB:</b>	-6.5 dBu

## RF Output

<b>Connector</b>	SMA (UHF and ShowLink); Shell=Ground, Center=Signal		
<b>Antenna Type</b>	Integrated Dual Band Helical		
<b>Power</b>	See Frequency Range and Output Power table		
<b>Mode</b>	<b>Frequency Diversity:</b>	Dual Carrier	
	<b>Single Carrier:</b>	Single Carrier	
<b>Impedance</b>	50 Ω		

## ShowLink ShowLink

<b>Network Type</b>	IEEE 802.15.4
<b>Frequency Range</b>	2.40 to 2.4835 GHz (16 Channels)
<b>RF Output Power</b>	10 dBm (ERP)

## Tables and Diagrams

### Frequency Range and Transmitter Output Power

Band	Frequency Range ( MHz)	Power ( mW)
G1	470 to 530	10/50
G1E	470 to 530	10/50
H4	518 to 578	10/50
H4E	518 to 578	10/50
J5	578 to 638	10/50
J5E	578 to 638	10/50
K4E	606 to 666	10/50
L3	638 to 698	10/50
L3E	638 to 698	10/50
L3HK	638 to 698	10
M8	666 to 730	10/50
P8	710 to 790	10/50
P9	710 to 787	10/50
Q5	740 to 814	10/50
MA24	779 to 806	2/10
MJBX	806 to 810	2/10

## System Gain

In an audio system containing both AXT400 and UR4 receivers, the overall system audio gain at the XLR (line) output varies depending on the receiver model and the type of transmitter.

The table below offers a comparison of the output gain at the XLR output for AXT400 and UR4 receivers for each transmitter model. Use the information in the table to achieve consistent gain levels when using systems comprised of both Axient series and UR series components.

### System gain from transmitter input to receiver XLR output (line) when transmitter gain = 0 dB

Transmitter		AXT100 Bodypack	AXT200 Handheld	UR1 Bodypack	UR1M Bodypack	UR2 Handheld
		gain = 0 dB	gain = 0 dB	gain = 0 dB	gain = 0 dB	gain = 0 dB
				sens = 0 dB	sens = 0 dB	
Receiver	AXT400	+10 dB gain	+15 dB gain	+15 dB gain	+15 dB gain	+15 dB gain
gain setting = 0 dB	UR4	N/A	N/A	+18 dB gain	+18 dB gain	+18 dB gain

## Certifications

Meets essential requirements of the following European Directives:

- R&TTE Directive 99/5/EC
- WEEE Directive 2002/96/EC, as amended by 2008/34/EC
- RoHS Directive 2002/95/EC, as amended by 2008/35/EC

**Note:** Please follow your regional recycling scheme for electronic waste

Meets requirements of the following standards: EN 300 328, EN 300 422 Parts 1 and 2, EN 301 489 Parts 1 and 9, EN60065.

Certified under FCC Part 15 and FCC Part 74.

Certified in Canada by IC to RSS-123 and RSS-210.

This Class B digital apparatus complies with Canadian ICES-003. Cet appareil numérique de la classe B est conforme à la norme NMB-003 du Canada.

This radio transmitter has been approved by Industry Canada to operate with the antenna types listed below with the maximum permissible gain and required antenna impedance for each antenna type indicated. Antenna types not included in this list, having a gain greater than the maximum gain indicated for that type, are strictly prohibited for use with this device.

**FCC ID:** DD4AXT200A, DD4AXT200B, DD4AXT200C, DD4AXT200D. **IC:** 616A-AXT200A, 616A-AXT200C, 616A-AXT200D.

This device complies with Industry Canada licence-exempt RSS standard(s). Operation of this device is subject to the following two conditions: (1) this device may not cause interference, and (2) this device must accept any interference, including interference that may cause undesired operation of the device.

Le présent appareil est conforme aux CNR d'Industrie Canada applicables aux appareils radio exempts de licence. L'exploitation est autorisée aux deux conditions suivantes : (1) l'appareil ne doit pas produire de brouillage, et (2) l'utilisateur de l'appareil doit accepter tout brouillage radioélectrique subi, même si le brouillage est susceptible d'en compromettre le fonctionnement.

The CE Declaration of Conformity can be obtained from Shure Incorporated or any of its European representatives. For contact information please visit [www.shure.com](http://www.shure.com)

The CE Declaration of Conformity can be obtained from: [www.shure.com/europe/compliance](http://www.shure.com/europe/compliance)

Authorized European representative:

Shure Europe GmbH

Headquarters Europe, Middle East & Africa

Department: EMEA Approval

Jakob-Dieffenbacher-Str. 12

75031 Eppingen, Germany

Phone: 49-7262-92 49 0

Fax: 49-7262-92 49 11 4

Email: [info@shure.de](mailto:info@shure.de)

### LICENSING INFORMATION

Licensing: A ministerial license to operate this equipment may be required in certain areas. Consult your national authority for possible requirements. Changes or modifications not expressly approved by Shure Incorporated could void your authority to operate the equipment. Licensing of Shure wireless microphone equipment is the user's responsibility, and licensability depends on the user's classification and application, and on the selected frequency. Shure strongly urges the user to contact the appropriate telecommunications authority concerning proper licensing, and before choosing and ordering frequencies.

### Information to the user

This equipment has been tested and found to comply with the limits for a Class B digital device, pursuant to Part 15 of the FCC Rules. These limits are designed to provide reasonable protection against harmful interference in a residential installation. This equipment generates uses and can radiate radio frequency energy and, if not installed and used in accordance with the instructions, may cause harmful interference to radio communications. However, there is no guarantee that interference will not occur in a particular installation. If this equipment does cause harmful interference to radio or television reception, which can be determined by turning the equipment off and on, the user is encouraged to try to correct the interference by one or more of the following measures:

- Reorient or relocate the receiving antenna.
- Increase the separation between the equipment and the receiver.
- Connect the equipment to an outlet on a circuit different from that to which the receiver is connected.
- Consult the dealer or an experienced radio/TV technician for help.



**United States, Canada, Latin  
America, Caribbean:**

Shure Incorporated  
5800 West Touhy Avenue  
Niles, IL 60714-4608 USA

Phone: 847-600-2000  
Fax: 847-600-1212 (USA)  
Fax: 847-600-6446  
Email: [info@shure.com](mailto:info@shure.com)

[www.shure.com](http://www.shure.com)

©2011 Shure Incorporated

**Europe, Middle East, Africa:**

Shure Europe GmbH  
Jakob-Dieffenbacher-Str. 12,  
75031 Eppingen, Germany

Phone: 49-7262-92490  
Fax: 49-7262-9249114  
Email: [info@shure.de](mailto:info@shure.de)

**Asia, Pacific:**

Shure Asia Limited  
22/F, 625 King's Road  
North Point, Island East  
Hong Kong

Phone: 852-2893-4290  
Fax: 852-2893-4055  
Email: [info@shure.com.hk](mailto:info@shure.com.hk)