UV-1G

WIRELESS INTERCOM SYSTEM



USER MANUAL

This page intentionally left blank.

IMPORTANT SAFETY INSTRUCTIONS

- READ and KEEP these instructions.
- Heed all warnings.
- Follow all instructions.
- Do not use this apparatus near water.
- Clean only with dry cloth.
- Do not block any ventilation openings. Install in accordance with the manufacturer's instructions.
- Do not install near any heat sources such as radiators, heat registers, stoves, or other apparatus (including amplifiers) that produce heat.
- Do not defeat the safety purpose of the polarized or grounding-type plug. (A grounding-type plug has two blades and a third grounding prong, whereas a polarized plug has two blades, one wider than the other. The wide blade or the third prong is provided for your safety. If the provided plug does not fit into your outlet, consult an electrician for replacement of the obsolete outlet.)
- Protect the power cord from being walked on or pinched, particularly at plugs, convenience receptacles, and the point where they exit from the apparatus.
- Only use attachments and/or accessories specified by the manufacturer.
- Use only with the cart, stand, tripod, bracket, or table included with the apparatus, or specified by the manufacturer.
When a cart is used, use caution when moving the cart/apparatus combination to avoid injury from tip-over.
- Unplug this apparatus during lightning storms, or when unused for long periods of time.

Refer all servicing to qualified service personnel.

Service is required when the apparatus has been damaged in any way, including:

Power-supply cord or plug is damaged, liquid has been spilled or objects have fallen into the apparatus, the apparatus has been exposed to rain or moisture, does not operate normally, or has been dropped.

WARNING

To prevent fire or shock hazard, do not expose the unit to rain or moisture.

To avoid electrical shock, do not open the cabinet. Refer maintenance to qualified personnel only.

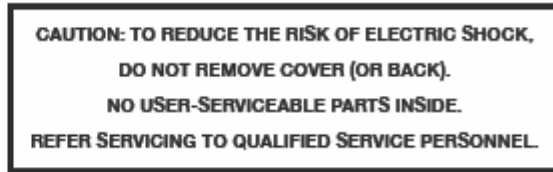

This symbol is intended to alert the user to the presence of uninsulated "dangerous voltage" within the product's enclosure that may be of sufficient magnitude to constitute a risk of electric shock to persons.



This symbol is intended to alert the user to the presence of important operating and maintenance (servicing) instructions in the literature accompanying the appliance.

WARNING

When installing the unit, incorporate a readily accessible disconnect device in the fixed wiring, or connect the power cord to socket-outlet which must be provided near the unit and easily accessible. If a fault should occur during operation of unit, operate the disconnect device to switch the power supply off, or disconnect the power cord.

CAUTION

This apparatus should not be exposed to dripping or splashing. No objects filled with liquid, such as vases, should be placed on the apparatus.

- Per FCC 15.19(a) (3) and (a) (4): This device complies with part 15 of the FCC Rules. Operation is subject to the following two conditions: (1) This device may not cause harmful interference, and (2) this device must accept any interference received, including interference that may cause undesired operation.
- Per FCC 15.21: Changes or modifications not expressly approved by Radio Active Designs could void the user's authority to operate the equipment.

TABLE OF CONTENTS

Table of Figures.....	9
Features	10
Terminology	10
Downloads / Manuals	11
Technical Support	11
UV-1G Specifications.....	12
Transmitter	12
Receiver	12
System Diagram	14
Base Station.....	15
Front Panel Button Descriptions	15
Front Panel LED Description	17
Rear Panel Description	19
Belt Pack.....	20
Quick Start Guide	23
Base Station	23
Belt Pack	24
Base Station Operation	25
Power	25
Home Screen	25
Transmitter Power Level	25
Receiver Status	26
Base Station Link Mode	26
Local Headset Status	28
RSSI Screen	28
Base Station Menu Structure.....	29
Passcode Protection	29
Receiver Settings	29
Advanced Receiver Settings	31
Aux In Settings	33
Transmitter Settings	34
Local Headset Options	35
Display Setting	36
Base Station Link Modes	38
Info Screen	38
Enabling/Disabling the Passcode	38
Changing the Passcode	39
Base Station Gain Adjustments.....	40
Intercom 1 & 2	40
Auxiliary	40
Stage Announce	41

Base Station Local Headset	42
Microphone Gain	42
Volume	42
Intercom CH1 and CH2 Buttons and LEDs	42
Talk Button	42
Belt Pack Operation	43
Battery	43
Powering Up	43
Powering Down	44
Home Screen	44
Talk Buttons and LEDs	44
Transmit Status Indicators	45
Signal and Battery Indicators	45
Headset Volume	45
Power / Menu Button	45
Belt Pack Menu Structure	46
Display Settings	46
Advanced Settings	49
Manage Scenes	50
Microphone Gain	60
PC App	62
Overview	62
Configuring the Base Station	62
Configuring the Belt Packs	62
Passcodes	62
Button Labels	62
Tips and Shortcuts	62
Menus	63
The File Menu	63
The Logging Menu	63
The Configure Menu	63
The Scenes Menu	64
The Options Menu	64
The Help Menu	64
The Popup Frequencies Menus	64
Base Station Tab	65
Receivers	65
Using Shortcut Keys	66
Routing	66
Transmitters	67
Intercoms	67
Gains	68
UI Display Settings	69
Passcode Enable	69

Base Station Mode	69
Mic & Headset Settings	70
Program Button	70
Base Station Connected	70
Belt Packs Tab	71
Top Section — Receivers and Button Labels	71
Belt Pack Id	71
Scene	71
Receiver One and Receiver Two	72
Receiver	72
Button Labels	73
Middle Section — Transmitter, Button Actions, and Battery Settings	73
Transmitter	73
Button Action	73
Double-Tap Action	73
Battery Settings	74
Bottom Section — UI Settings, Passcode, and Mic & Headset	74
UI Settings	74
Mic & Headset	74
Master Volume	75
Program	75
Belt Pack Connected	75
Add Scene	76
Remove Scenes	76
Rename Scenes	77
Write To Belt Packs	77
Diagnostics	77
Passcodes	78
Button Labels	79
Write To Belt Packs	79
Device Firmware Update	80
Base Station Firmware	80
Belt Pack Firmware	80
Automatic Updates	81
Current and Requested Versions	81
Update Button	81
Close Button	81
Software Preferences.....	81
On Start-Up	81
Software Updates	81
Permit Use of Channel 37	82
Device Info	82
Base Station Info	82
Belt Pack Info	82

About RAD UV-1G	83
Use of Open Source Software	83
Appendix A	84
<i>2W Pin out</i>	<i>84</i>
<i>4w pin out</i>	<i>85</i>
Troubleshooting & FAQs	86

TABLE OF FIGURES

FIGURE 1 UV-1G FRONT PANEL BUTTONS	15
FIGURE 2 FRONT PANEL LED DESCRIPTIONS	17
FIGURE 3 BASE STATION REAR PANEL.....	19
FIGURE 4 BELT PACK TOP VIEW.....	20
FIGURE 5 BELT PACK SIDE VIEWS	21
FIGURE 6 BELT PACK BOTTOM VIEW.....	22
FIGURE 7 BASE STATION.....	25
FIGURE 8 BELT PACK POWER BUTTON	43

GENERAL INFORMATION

The Radio Active Designs® UV-1G is a two-channel full-duplex UHF/VHF wireless intercom system that utilizes up to six wireless Belt Pack units per Base Station.

Each Belt Pack is capable of simultaneous **Talk and Listen** on two separate audio channels. Additionally, Belt Packs have **Stage Announce** and two-channel **Wireless Talk-Around**.

Wired Interface supports 2W Audiocom® (Telex), RTS® TW, and Clear-Com® varieties.

RJ-11 compatible jacks support 4W systems.

FEATURES

- Excellent RF noise immunity through revolutionary design
- Full duplex operation utilizes UHF transmitters and VHF receivers
- Support for up to six Belt Pack units in one Base Station
- Two wireless intercom channels
- Programmability via PC interface or User Interface in the field
- Internal antenna in Belt Pack
- Extremely low occupied bandwidth
- Frequency Response: 100Hz to 8kHz
- Audio Dynamic Range \geq 50dB
- AES-48 Compliant

TERMINOLOGY

- LCD – Liquid Crystal Display
- LED – Light Emitting Diode
- WTA – Wireless Talk-Around
- SA – Stage Announce
- 4W – 4-Wire
- 2W – 2-Wire
- VHF – Very High Frequency
- UI – User Interface
- UHF – Ultra High Frequency
- IEC – International Electrotechnical Commission
- FCC – Federal Communications Commission
- RSSI – Received Signal Strength Indicator

DOWNLOADS / MANUALS

The following downloads are available on the RAD website:

<http://radioactivevf.com/home/troubleshooting/downloads>

Base Station/Belt Pack PC Software

- Windows 64-bit
- Windows 32-bit
- Macintosh
- Linux

Note: Do not uninstall the old application before installing the new version. The new applications contain belt pack and base station firmware. Once installed it can automatically download the latest firmware.

Battery Charger

PC Software

Firmware Update

Manuals

UV-1G Manual (this document)

Dimensions

Belt Pack Dimensions

Battery Dimensions

TECHNICAL SUPPORT

Please contact technical support for direct assistance.

Monday – Friday

8 am – 6 pm PST

technicalsupport@radioactivevf.com

Phone: 402.477.0695

UV-1G SPECIFICATIONS

RF Frequency Range	470.025-607.975 and 614.025-697.975MHz Base Tx, 174.025-215.975MHz Belt Tx
Power Requirements	13.8-21 VDC, 75W, Switchcraft RASPC10P Receptacle
Temperature Range	-4° F to 131° F (-20° C to 55° C)
Dimensions	
Base Station	14.68" x 17" x 1.75"
Belt Pack	5.55" x 3.78" x 1.83"
Weight	
Base Station	7 lbs.
Belt Pack	16 Oz
TX Antenna	
Belt Pack	Internal
Base Station	5/8 wave (Supplied)
RX Antenna	
Belt Pack	Internal
Base Station	1/4 wave (Supplied)
FCC ID	2AA6F-UV-1GBP, 2AA6F-UV-1GBS
IC ID	11482A-UV1GBP, 11482A-UV1GBS
Frequency Response	100Hz-8 kHz
Two Wire Max Input Voltage	+8 dBu
Four Wire Max Input Voltage	+20 dBu
Auxiliary Input	Adjustable (2Vrms typical)
Auxiliary Output	Adjustable (2Vrms typical into 600Ω)
Stage Announce Output	Internally Adjustable (2Vrms typical at rated deviation into 600Ω)
Stage Announce Relay	Dry Contact, rated at 1 Amp, 24V Max
Mic Input Sensitivity	9mV
Local Headset Output	40mW output into 600Ω (1% Distortion)

TRANSMITTER

Type	Two Transmitters, Synthesized
Transmit Power (each transmitter)	Base: 20mW–250mW, Belt: 10mW–50mW (Part 74 and Part 15 qualified)
Modulation Type	Enhance Narrow Band
RF Frequency Stability	±1.5ppm
Occupied Bandwidth	25 kHz
Radiated Harmonics and Spurious	Exceeds FCC Requirements

RECEIVER

Type	Direct Conversion
RF Sensitivity	-110dBm for 12dB SINAD
Squelch Threshold	Automatic
IF Selectivity	25 kHz

RF Frequency Stability
Distortion

± 1.5 ppm
<1% at full modulation

SYSTEM DIAGRAM

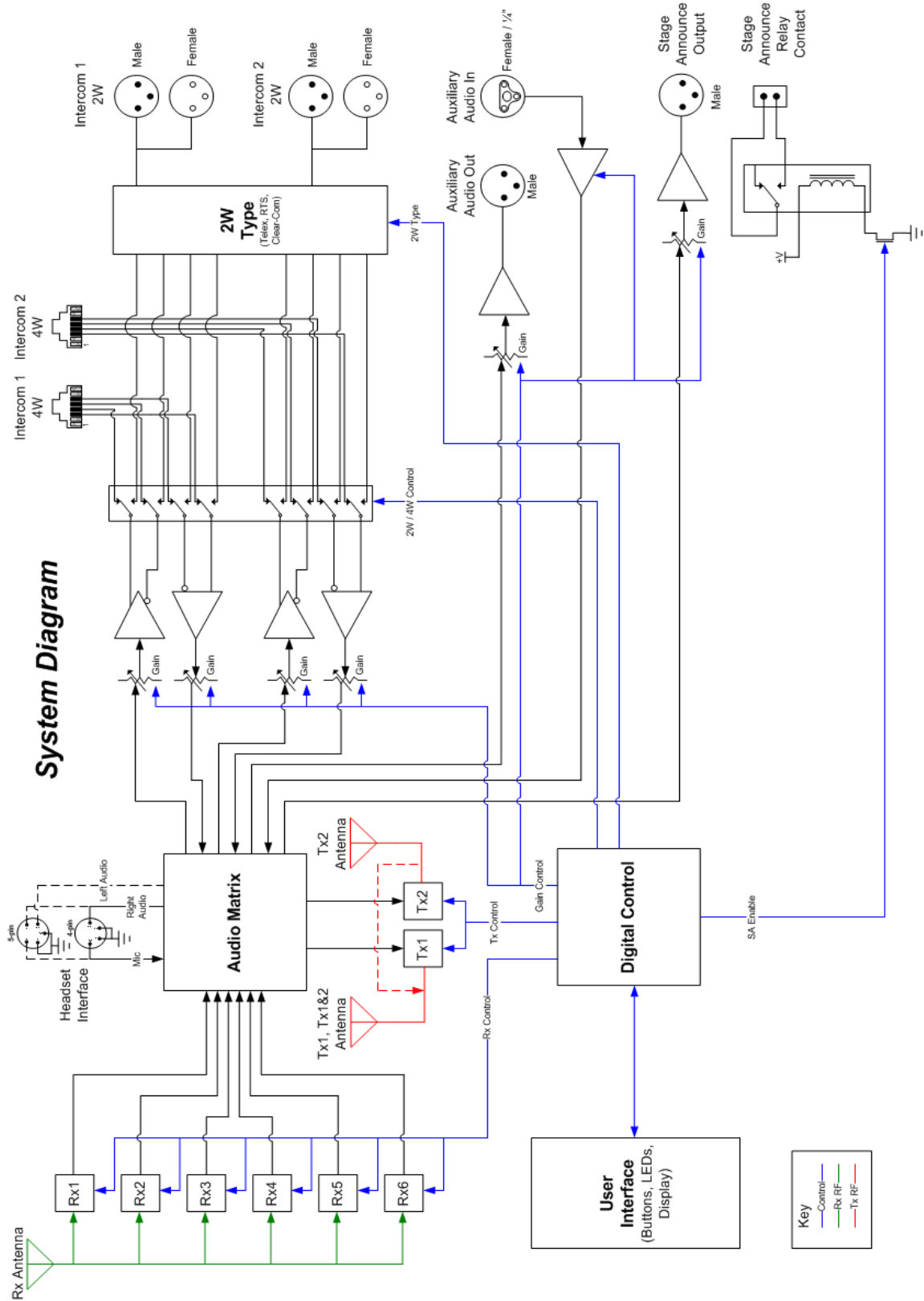

FRONT PANEL BUTTON DESCRIPTIONS

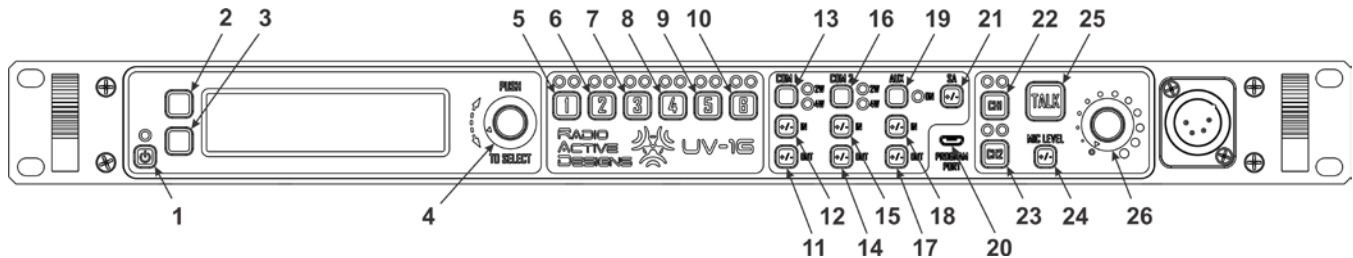

Figure 1 UV-1G Front Panel Buttons

1. **POWER BUTTON**
Momentary press to power up unit
Press and hold to power off
2. **SOFT KEY 1**
Menu Navigation
Variable button function
3. **SOFT KEY 2**
Menu Navigation
Variable button function
4. **ROTARY ENCODER AND SELECT**
Rotate for Menu Navigation
Press to make selection of a given menu option
5. **CHANNEL 1 MUTE/UNMUTE**
Momentary press to Mute or Unmute Belt Pack #1
6. **CHANNEL 2 MUTE/UNMUTE**
Momentary press to Mute or Unmute Belt Pack #2
7. **CHANNEL 3 MUTE/UNMUTE**
Momentary press to Mute or Unmute Belt Pack #3
8. **CHANNEL 4 MUTE/UNMUTE**
Momentary press to Mute or Unmute Belt Pack #4
9. **CHANNEL 5 MUTE/UNMUTE**
Momentary press to Mute or Unmute Belt Pack #5
10. **CHANNEL 6 MUTE/UNMUTE**
Momentary press to Mute or Unmute Belt Pack #6
11. **INTERCOM 1 OUTPUT GAIN**
Momentary press to show Intercom 1 Output Gain screen on LCD
See Gain Adjustments section.
12. **INTERCOM 1 INPUT GAIN**
Momentary press to show Intercom 1 Input Gain screen on LCD
See Gain Adjustments section.

13. INTERCOM 1 SELECT

Momentary press toggles Intercom 1 between one of three options: 2-wire, 4-wire, Off

14. INTERCOM 2 OUTPUT GAIN

Momentary press to show Intercom 2 Output Gain screen on LCD

See Gain Adjustments section.

15. INTERCOM 2 INPUT GAIN

Momentary press to show Intercom 2 Input Gain screen on LCD

See Gain Adjustments section.

16. INTERCOM 2 SELECT

Momentary press toggles Intercom 2 state between one of three options: 2-wire, 4-wire, Off

17. AUXILIARY OUTPUT GAIN

Momentary press to show Auxiliary Output Gain screen on LCD

See Gain Adjustments section.

18. AUXILIARY INPUT GAIN

Momentary press to show Auxiliary Input Gain screen on LCD

See Gain Adjustments section.

19. AUXILIARY ENABLE/DISABLE

Momentary press enables or disables Auxiliary Input and Output

20. PROGRAM PORT

The Program Port is a USB Micro-B compatible port that is used for configuring UV-1G Base Stations and Belt Packs or upgrading firmware via the UV-1G PC Application. For convenience, the UV-1G Belt Pack will power on when the cable is plugged in and connected to a PC, the Base Station will not.

21. STAGE ANNOUNCE GAIN

Momentary press to show Stage Announce Gain screen on LCD

See Gain Adjustments section.

22. CHANNEL 1 ENABLE/DISABLE

Momentary press toggles the ability for local headset to talk/listen on intercom Channel 1

23. CHANNEL 2 ENABLE/DISABLE

Momentary press toggles the ability for local headset to talk/listen on intercom Channel 2

24. HEADSET MICROPHONE GAIN

Momentary press to show Headset Microphone Gain screen on LCD

See Gain Adjustments section.

25. TALK BUTTON

Momentary button press latches local headset talk on channels determined by the status of 22 and 23

Press and hold for non-latching operation

26. HEADSET VOLUME

Headset volume audio potentiometer

FRONT PANEL LED DESCRIPTION

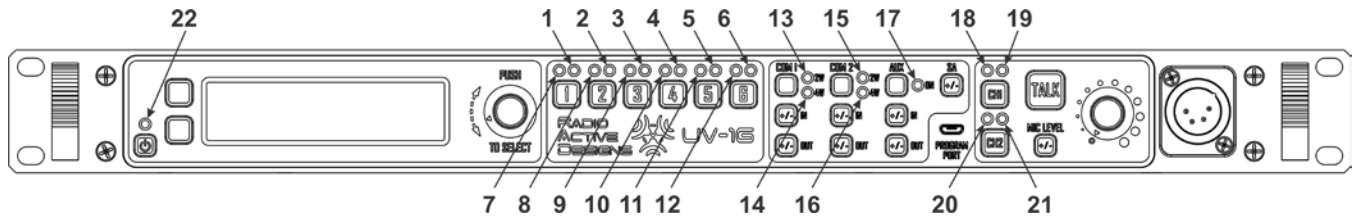

Figure 2 Front Panel LED Descriptions

- 1-6. **CHANNEL N STATUS LED**
Green = Receiver signal present
Flashing Red = Belt Pack battery low
Alternating Green/Red = Receiver signal present and Belt Pack battery low
- 7-12. **CHANNEL N MUTE LED**
Green = Channel enabled
Yellow = Channel muted
Off = Channel disabled
13. **INTERCOM 1 2-WIRE ENABLE LED**
Green = Enabled
Red = Over Modulation
Off = Disabled
14. **INTERCOM 1 4-WIRE ENABLE LED**
Green = Enabled
Red = Over Modulation
Off = Disabled
15. **INTERCOM 2 2-WIRE ENABLE LED**
Green = Enabled
Red = Over Modulation
Off = Disabled
16. **INTERCOM 2 4-WIRE ENABLE LED**
Green = Enabled
Red = Over Modulation
Off = Disabled
17. **AUXILIARY ENABLE LED**
Green = Enabled
Red = Over Modulation
Off = Disabled
18. **LOCAL HEADSET CHANNEL 1 ENABLE LED**
Green = Enabled
Off = Disabled
19. **LOCAL HEADSET CHANNEL 1 STATUS LED**

Green = Local headset traffic on Channel 1 (Talk button pressed, local headset Channel 1 enabled)

Red = Over Modulation

Off = No traffic

20. **LOCAL HEADSET CHANNEL 2 ENABLE LED**

Green = Enabled

Off = Disabled

21. **LOCAL HEADSET CHANNEL 2 STATUS LED**

Green = Local headset traffic on Channel 2 (Talk button pressed, local headset Channel 2 enabled)

Red = Over modulation

Off = No traffic

22. **POWER / FAN FAIL LED**

Green = System powered up

Red = Fan failure condition

REAR PANEL DESCRIPTION

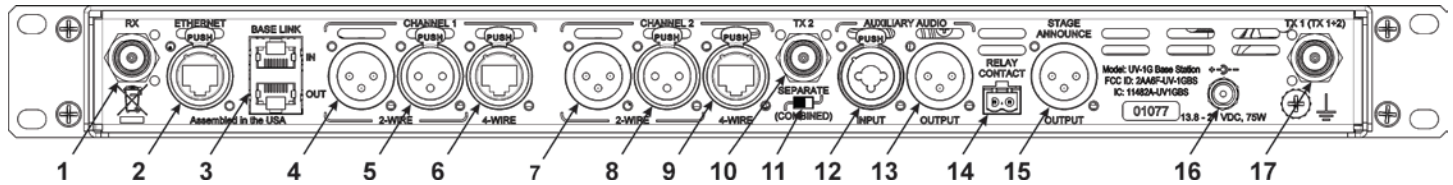

Figure 3 Base Station Rear Panel

1. Receive antenna (BNC)
2. Ethernet RJ-45 Port
3. Base Link RJ-45 Port
4. Intercom 1 3-pin XLR Male
5. Intercom 1 3-pin XLR Female
6. Intercom 1 4-wire port
7. Intercom 2 3-pin XLR Male
8. Intercom 2 3-pin XLR Female
9. Intercom 2 4-wire port
10. Transmit Antenna 2 (BNC)
11. Transmit Antenna Selection Switch
12. Auxiliary XLR 3-pin with 1/4" audio input
13. Auxiliary XLR 3-pin audio output
14. Stage Announce Relay Contact
15. Stage Announce XLR 3-pin audio output
16. DC Power Input
17. Transmit Antenna 1 or 1 & 2 combined (BNC)

NOTE: See [Appendix A](#) for XLR pin out.

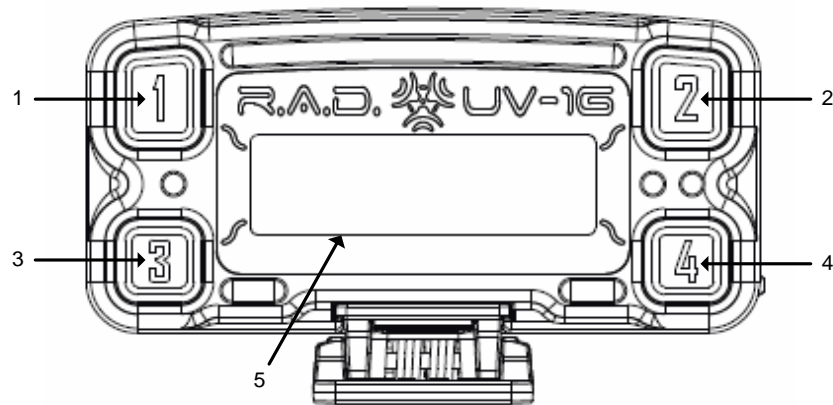

Figure 4 Belt Pack Top View

1. CHANNEL 1 BUTTON

At Home Screen: Push to transmit on Channel 1

In Menu: Select boxed item

- **TALK / OVER MODULATION LED FOR CHANNEL 1**

LED turns on when the Channel 1 talk button is pressed

Green while the transmitter is active

Red if over modulation occurs

2. Channel 2 Button:

At Home Screen: Push to transmit on Channel 2

In Menu: Select boxed item

- **TALK / OVER MODULATION LED FOR CHANNEL 2**

LED turns on when the Channel 2 talk button is pressed

Green while the transmitter is active

Red if over modulation occurs

3. SOFT KEY 1 BUTTON

At Home Screen: Push to transmit on User-configured Channel (1+2, WTA 1, WTA 2, WTA 1+2, SA, Aux)

In Menu: Functions as “soft key” described on the LCD

- **TALK / OVER MODULATION LED FOR THE PROGRAMMABLE 1 TALK BUTTON**

LED turns on when pressed

Green while the transmitter is active

Red if over modulation occurs

4. SOFT KEY 2 BUTTON

At Home Screen: Push to transmit on User-configured Channel (1+2, WTA 1, WTA 2, WTA 1+2, SA, Aux)

In Menu: Functions as “soft key” described on the LCD

- **TALK / OVER MODULATION LED FOR THE PROGRAMMABLE 2 TALK BUTTON**

LED turns on when pressed
Green while the transmitter is active
Red if over modulation occurs

5. LCD WITH BACKLIGHT

Backlight turns on when button is pressed if Belt Pack is not set up to blackout backlight

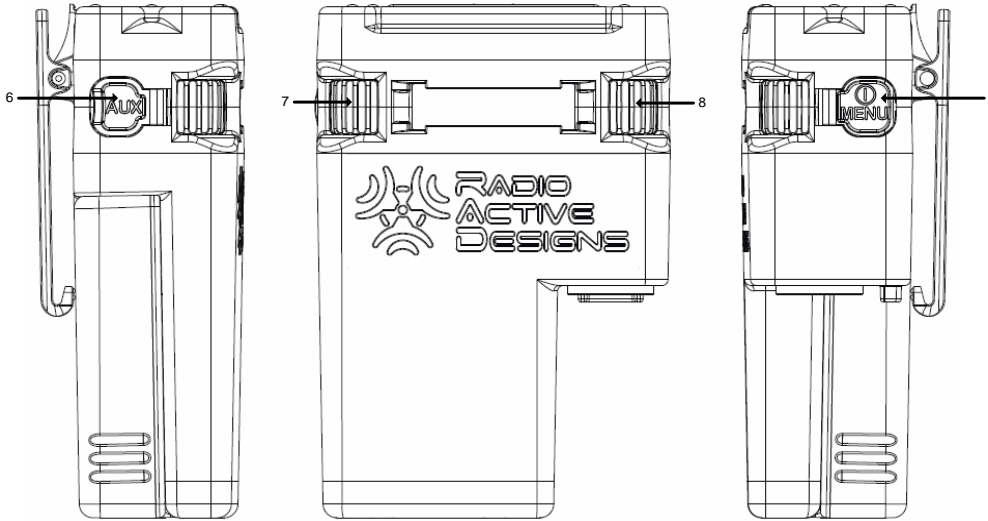

Figure 5 Belt Pack Side Views

6. AUXILIARY PORTS

USB port and Auxiliary Audio Input

7. RIGHT ENCODER

At Home Screen: Adjusts Headset volume for Channel 2

In Menu: Navigation; changing values

8. LEFT ENCODER

At Home Screen: Adjusts Headset volume for Channel 1

In Menu: Navigation; changing values

9. POWER / MENU BUTTON

Momentary press turns Belt Pack on; toggles Menu

Press and hold turns OFF

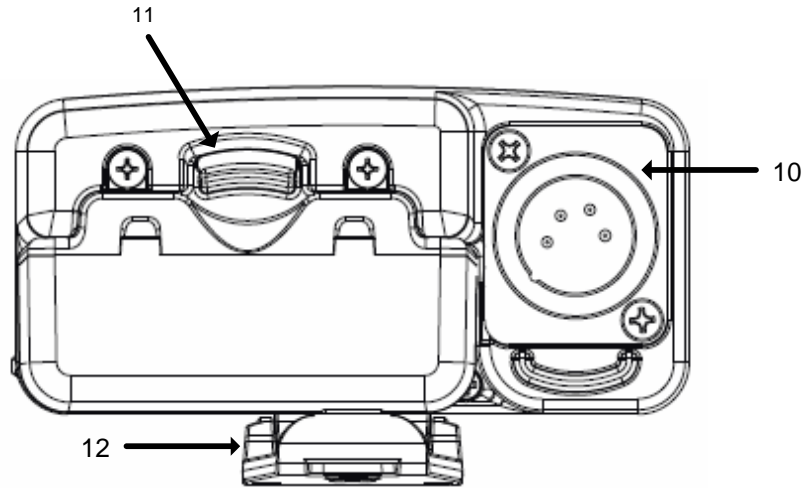

Figure 6 Belt Pack Bottom View

10. HEADSET CONNECTOR

Four Pin XLR male (shown); Five Pin XLR female

11. BATTERY LATCH

12. REMOVABLE BELT CLIP

QUICK START GUIDE

BASE STATION

1. **POWER:** Insert power supply plug into the power connector located on the back of the Base Station.
2. **ANTENNAS:** Connect the supplied Shure VHF antenna (Green stripes) to RX input. Connect the Shure UHF antenna (Pink stripes) to TX1 (TX1+2) output. Ensure switch is set to combined mode.
3. **CONNECT HEADSET:** Insert the headset connector into the Base Station until it snaps into place.
4. **POWERING ON/OFF:** Press and hold the power button to power on. The display will turn on, as well as various LEDs. Press and hold the power button to power off.
5. **TX & RX FREQUENCIES:** Program the transmitter and receiver frequencies as desired. See the UV-1G PC Application (supplied) for information on how to program frequencies from the Base Station itself.

NOTE: Defaults for Rx 1 – Rx 6 are 175MHz, 176MHz, 177MHz, 178MHz, 179MHz, and 180MHz. The default for Tx1 is 519MHz and Tx2 is 520MHz.

6. **INTERCOM 2W / 4W:** Select Audiocom (Telex), Clear-Com, or RTS mode via the menu. Enable the 2W or 4W intercom using the intercom 1 and 2 select buttons (see Front Panel Button Descriptions).

After connecting the 2W intercom to an external 2W device, the given intercom channel (CH1 or CH2) must tune itself in order to maximize nulling of undesirable audio artifacts. Upon power-up, the Base Station will automatically perform the 2W tuning process: a low level of white noise is sent on the given 2W channel line for a few seconds.

Upon tuning completion, the intercom is ready to use. If a wired intercom is connected while the Base Station is powered on, the tuning process must be manually started by the user: press the Intercom Select button (CH1 or CH2) until the intercom goes from disabled to enabled, at which point the tuning process will begin.

NOTE: This tuning process is only for wired 2W intercoms. It does not affect the 4W intercoms.

BELT PACK

1. **POWER:** Insert the battery pack into the Belt Pack so contacts meet and clip is secure so the battery pack cannot slide off. If using AA battery pack (BP/AA) insert AA Energizer L91 lithium batteries or equivalent into the provided battery sled. Ensure cover has snapped into place.
NOTE: Rechargeable battery packs (BP-L) are recommended for optimal long-term use. AA batteries should be used as backup.
2. **CONNECT HEADSET:** Insert the headset connectors into the Belt Packs until they snap into place.
3. **POWERING ON/OFF:** Press and hold the Power/Menu button located on the side of the Belt Pack to power on or off the Belt Pack. The display will turn on or off accordingly.
4. **TX & RX FREQUENCIES:** Program the transmitter and receiver frequencies as desired. See Belt Pack Operation section or PC Application for information on how to program frequencies from the Belt Pack itself.
NOTE: the default for Rx1 is 519MHz, Rx2 is 520MHz, and TX is 175MHz. These values will work with the Base Station defaults for one Belt Pack (Belt Pack #1). The other Belt Packs will need their frequencies changed from the defaults.

CONGRATULATIONS, YOUR NEW UV-1G IS READY FOR USE!

BASE STATION OPERATION



Figure 7 Base Station

POWER

The Base Station is powered by 120VAC, 2.5A (max) using a standard IEC power cable to a low voltage power supply.

Powering Up

To turn the Base Station on, press the **POWER** button (see #1 on Figure 1).

While the Base Station powers up, the following splash screen will appear:

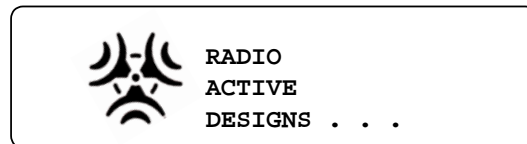

Once the Base Station is ready for use, the Home Screen will be displayed.

Powering Down

To turn the Base Station off, press and hold the **POWER** button until the LCD screen goes blank.

HOME SCREEN

The Home Screen is the root of the UV-1G Base Station UI. It displays information regarding transmitter power level, receiver status, Base Station link mode, and local headset status. The left portion of the screen provides links to the main menu and RSSI screens.

MENU	M	R1 C1	R4 OFF
	T1 50mW	R2 C2	R5 NTx
	T2 50mW	R3 OFF	R6 W1
RSSI	HS: OFF		

TRANSMITTER POWER LEVEL

Indicators **T1** and **T2** represent Transmitter 1 and Transmitter 2.

Options: **20mW**, **50mW (Part 15)**, and **100mW**, **250mW (Part 74 only)**.

See **TRANSMITTER SETTINGS** for details on changing these parameters.

RECEIVER STATUS

Indicators **R1** through **R6** represent the status of the receivers (transmit status for each Belt Pack). This is how the received audio is being routed in the Base Station. The table below shows the different receiver status codes and their descriptions.

Code	Description
OFF	Receiver is off (disabled)
NTx	Receiver is enabled and the Belt Pack is not transmitting, or the Belt Pack is transmitting and the audio isn't being routed (muted)
C1	Intercom Channel 1
C2	Intercom Channel 2
C12	Intercom Channels 1&2
W1	Wireless Talk Around 1
W2	Wireless Talk Around 2
W12	Wireless Talk Around 1&2
AO	Auxiliary Output
A1	Auxiliary Output plus Wireless Talk Around 1
A2	Auxiliary Output plus Wireless Talk Around 2
A12	Auxiliary Output plus Wireless Talk Around 1&2
SA	Stage Announce
S1	Stage Announce plus Wireless Talk Around 1
S2	Stage Announce plus Wireless Talk Around 2
S12	Stage Announce plus Wireless Talk Around 1&2
CUS	Custom, any other route not in this table
	If blank, the receiver module is not installed

BASE STATION LINK MODE

Base Link is a method of connecting up to six Base Stations together in order to expand the number of Belt Packs that a system can handle. When two or more Base Stations are linked together, one must be set up as the **MASTER** and the rest as a **SLAVE**. The slave Base Station transmitters and wired intercoms will be disabled, but will route wireless Belt Pack audio data to the master unit. In effect, this means that up to 36 Belt Packs can be used in a single wireless two-channel system.

The Base Station Link Mode status appears on the Home Screen above the power level indication for transmitter 1 (**T1**). The letter **M** stands for Master and **S** for Slave.

MENU	M	R1 C1	R4 OFF
	T1 50mW	R2 C2	R5 NTx
	T2 50mW	R3 OFF	R6 W1
RSSI	HS: OFF		

The Base Stations are connected together via the Base Link Jack (see Figure 3 Base Station Rear Panel) and a standard RJ-45 network cable (straight-through only). The maximum Base Link cable length is five feet. While longer cables *may* work, full functionality is not guaranteed for cables longer than five feet.

Example Setup Procedure for Base Link with Six Base Stations:

1. Choose a Master Base Station and set it up as Master via the **LINK SETTINGS** in the main menu (see Base Station Link Modes section). In the same manner, the other Base Stations need to be set to Slave.
2. With all Base Stations powered off, connect the Base Stations together via the Base Link cables in the following manner:
 - a. Master OUT → Slave #1 IN
 - b. Slave #1 OUT → Slave #2 IN
 - c. Slave #2 OUT → Slave #3 IN
 - d. Slave #3 OUT → Slave #4 IN
 - e. Slave #4 OUT → Slave #5 IN
 - f. Slave #5 OUT → Slave #6 IN
3. Power ON all Base Stations in the order of Master first, Slave #1 second, Slave #2 third, etc. It is not necessary to wait for each Base Station to completely finish booting prior to pressing the power button for the next. Powering on the Base Stations in a different sequence can cause Slave units to lock up, depending on the order. If a lock-up occurs, hold the power button for approximately 10 seconds to force a power down.

NOTE: Powering off a system or adding/removing a Base Link cable during operation is not recommended, and at minimum will cause systems to reboot. In the above six Base Station Base Link example, removing the Base Link cable from a Slave unit, e.g. Slave #3, will cause every slave down the chain (e.g. 4, 5, 6) to crash, which may require a manual reboot to resolve. Powering off a base station in the chain will have a similar effect. To power down a number of systems in Base Link Mode, start with the end of the chain. In the above example, power off slave #6 first, followed by slaves 5-1, until finally ending with the master unit.

When Base Link cables are connected, all units are synchronized to the same system reference clock, which is passed unit-to-unit over the Base Link cable. This is automatic and not user controllable. When a unit is powered on, the internal electronics check for the presence of an external reference clock. If the external clock is detected, the system boots using the external one. If the external clock is not detected, the system boots from its own internal clock. Whenever the external clock is present, the internal electronics will automatically switch to using this reference. This clock switching is independent of master/slave operation.

Base Sync

It may be desirable in certain system setups to connect the Base Link cable between two Base Stations, without using them in the Base Link mode. This means that both Base Stations are set up as Master in the Link Settings (transmitters, wired intercoms, etc. enabled).

For example, if a Belt Pack needs to be able to have one receiver tuned to Base Station A Channel 1 and the other Belt Pack receiver tuned to Base Station B Channel 2, the Base Link cable would need to be connected between Base Station A and Base Station B to get the clock sources for the two Base Stations in sync.

LOCAL HEADSET STATUS

The Local Headset Status information is labeled as **HS**. The table below shows the different Local Headset Status codes and its description.

Code	Description
OFF	Local headset is disabled.
T/L	Local headset is enabled. Talk and listen capability is enabled.
LO	Talking is disabled (listen only).

RSSI SCREEN

To get to the RSSI (Received Signal Strength Indication) screen, press the bottom soft key labeled **RSSI**.

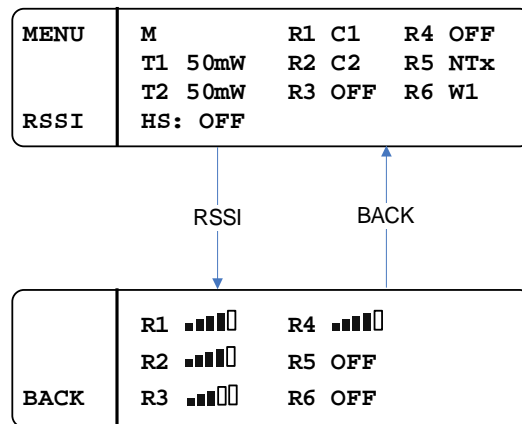

The RSSI screen, shown above, displays the signal strength of each receiver. **OFF** means that particular receiver is disabled.

BASE STATION MENU STRUCTURE

PASSCODE PROTECTION

The Base Station menu can be protected by a passcode.

- From the home screen, press the **MENU** button to change the screen as shown below:

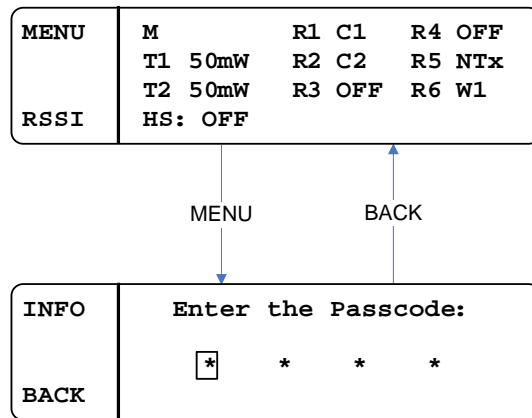

The passcode is four digits; each digit can be any 0 – 9 number.

- Use the rotary encoder (see #4 on Figure 1) to change the value.
- Press **SELECT** to change selected (boxed) digit.
- Once the last digit is entered, press **SELECT**.

If the entered passcode is correct, the menu screen will be displayed.

If it is incorrect, **INVALID PASSCODE** will display for three seconds before returning to the home screen.

See **ENABLING/DISABLING THE PASSCODE** and **CHANGING THE PASSCODE** for instructions on how to enable/disable and change the passcode.

RECEIVER SETTINGS

The receiver settings allow the user to change the receiver frequencies, as well as enable or disable them.

- From home screen, press **MENU**, scroll to **RX SETTINGS**, press **SELECT**.

The screen will appear as follows:

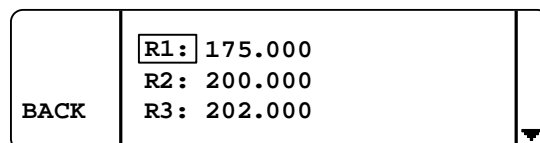

This screen displays the frequency (in MHz) of all six receivers.

If a given receiver is disabled, the word **DISABLED** will appear in place of a numerical frequency value.
 If a receiver is not installed, it will display **NOT INSTALLED**.

- Use the rotary encoder to navigate to the desired receiver and press **SELECT** to change the receiver frequency or status (enabled / disabled).

The following is an example of selecting **R1**:

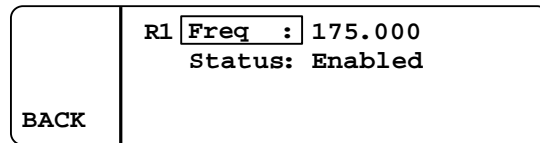

- To change the frequency, press **SELECT**; the first frequency digit will be boxed (see below).
- Use the encoder to change the value of the boxed digit (up / down).
- Press **SELECT** to move on to the next digit.
- Once the frequency has been changed as desired, press **SAVE** to save the change or **BACK** to cancel.

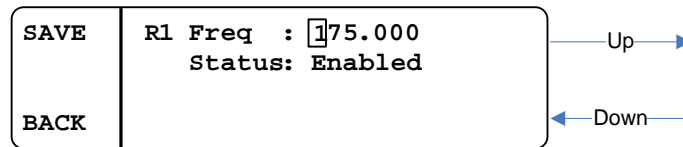

- To change the status, scroll down to **STATUS** and press **SELECT**.
- Use the encoder to change the selection and press **SAVE** to save the change.

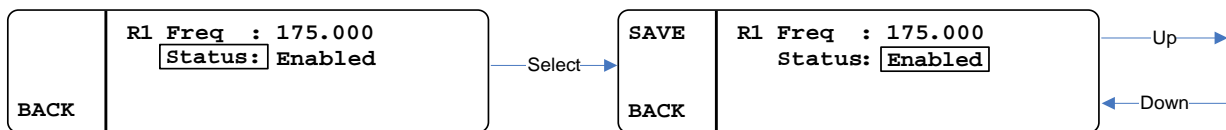

ADVANCED RECEIVER SETTINGS

The advanced receiver settings allow the user to adjust squelch and input attenuation settings for all six receivers individually (R1- R6) or on a global basis. Additionally, receiver routing settings can be configured in this menu.

- From home screen, press **MENU**, scroll to **ADVANCED RX SETTINGS**, press **SELECT**.

The screen will appear as follows:

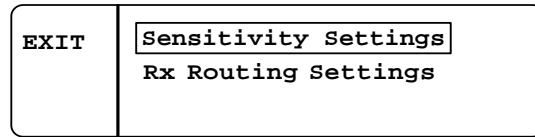

To access the sensitivity settings, press **SELECT**. A new screen will appear as follows:

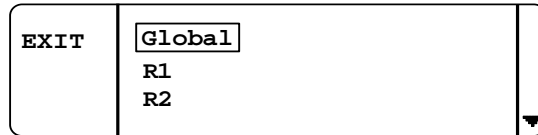

The sensitivity settings include squelch and input attenuation. Any changes to these parameters under the global selection will affect all six receivers. Alternatively, squelch and input attenuation can be set individually for any receiver, one (R1) through six (R6).

The following is an example of selecting **R1** for **Sensitivity Settings**:

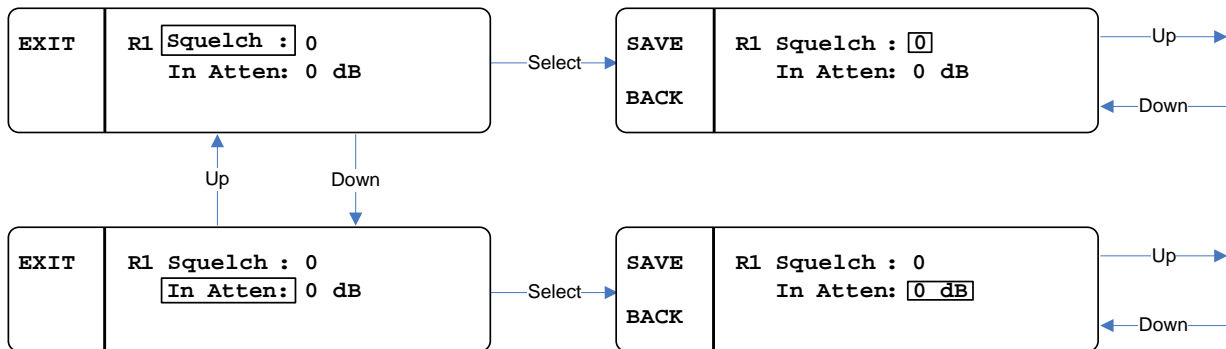

- Use the encoder to change the value.
- Squelch options are 0 – 9.
- Input attenuation options are 0dB, 5dB, 10dB, and 20dB.
- Press **SAVE** to save the change or **BACK** to cancel.

To access the **Rx Routing Settings**, select it from the **ADVANCED RX SETTINGS** sub-menu within the main menu.

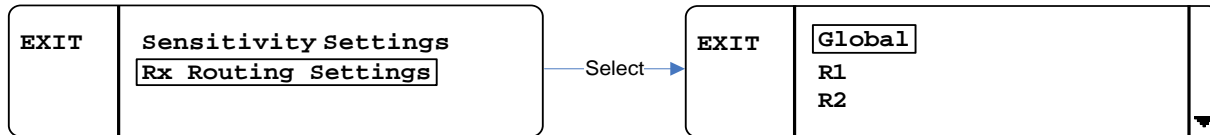

The receiver routing settings are used to set the audio routing from Belt Packs for the six receivers. Any changes to these parameters under the global selection will affect all of the receivers. Alternatively, each receiver can be set individually (R1 – R6).

Pressing **SELECT** on **Global** or one of the receivers (R1 – R6) will display a screen as follows:

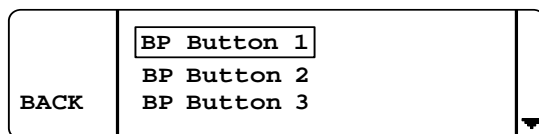

The routing for each Belt Pack button is set separately. There are six outputs that the audio can be routed to: Wireless Intercom 1, Wireless Intercom 2, Wired Intercom 1, Wired Intercom 2, Auxiliary Out, and Stage Announce. The audio can be routed to any combination of outputs.

The following is an example of selecting **R1** then **BP Button 1**:

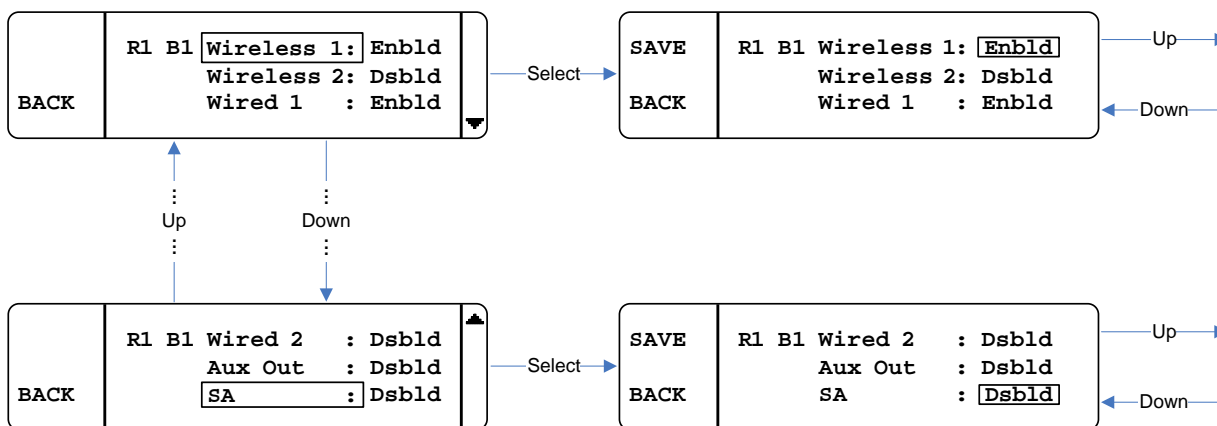

- Use the encoder to change the value.
- Options are **Enbld** (for enabled) and **Dsbld** (for disabled).
- Press **SAVE** to save the change or **BACK** to cancel.

The following table shows the settings for common routes:

Description	Settings (Wireless 1, Wireless 2, Wired 1, Wired 2, Aux Out, and SA)
Muted (no route)	Dsbld, Dsbld, Dsbld, Dsbld, Dsbld, Dsbld
Intercom Channel 1	Enbld, Dsbld, Enbld, Dsbld, Dsbld, Dsbld
Intercom Channel 2	Dsbld, Enbld, Dsbld, Enbld, Dsbld, Dsbld
Intercom Channels 1&2	Enbld, Enbld, Enbld, Enbld, Dsbld, Dsbld
Wireless Talk Around 1	Enbld, Dsbld, Dsbld, Dsbld, Dsbld, Dsbld
Wireless Talk Around 2	Dsbld, Enbld, Dsbld, Dsbld, Dsbld, Dsbld
Wireless Talk Around 1&2	Enbld, Enbld, Dsbld, Dsbld, Dsbld, Dsbld
Auxiliary Output	Dsbld, Dsbld, Dsbld, Dsbld, Enbld, Dsbld
Stage Announce	Dsbld, Dsbld, Dsbld, Dsbld, Dsbld, Enbld

AUX IN SETTINGS

The Aux In settings control the functionality of the auxiliary input. There are three options for each intercom (1&2) regarding the auxiliary input:

- **Off** – audio from the Aux In port will not be routed on the given intercom.
- **Local** – audio from the Aux In port will be routed to the given wireless intercom and the local headset.
- **Global** – audio from the Aux In port will be routed to the given wireless intercom, local headset, and the given wired intercom.

The Aux In settings can be accessed from the main menu. Below is an example of the Aux In settings sub-menu.

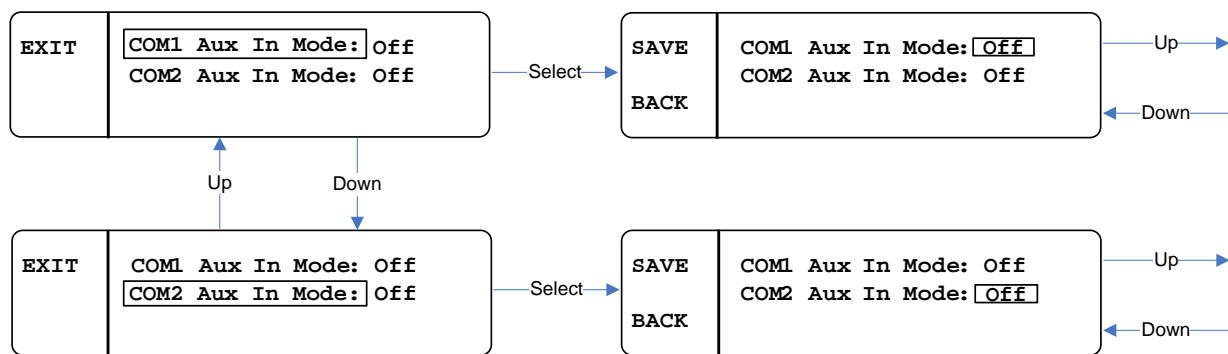

- Use the encoder to change the value.
 - Options are Off, Local, and Global.
- Press **SAVE** to save the change or **BACK** to cancel.

TRANSMITTER SETTINGS

The transmitter settings allow the user to change the transmitter frequencies and power levels as well as enabling/disabling them.

- From the home screen, press **MENU**, scroll to **TX SETTINGS**, press **SELECT**.

The screen will appear as follows:

BACK	T1: 100mW	496.000
	T2: 100mW	649.000

This screen lists the frequency (in MHz) of transmitters, power level, and status (enabled/disabled).

If a transmitter is not installed, it will display **NOT INSTALLED**.

For example, if Transmitter One is disabled, **T1: DISABLED** will be displayed. If it is enabled, then it will be displayed as it is shown above.

- To change any of these settings, scroll to the transmitter you desire to change, press **SELECT** and the screen will appear as follows:

BACK	T1	Power :	100mW
		Freq :	496.000
		Status:	Enabled

- To change the transmitter power, press **SELECT**.
- Use the encoder to change the value.
- Press **SAVE** to save or **BACK** to cancel the change.

SAVE	T1	Power :	100mW	Up →
BACK		Freq :	496.000	
		Status:	Enabled	← Down

- To change the frequency, select **FREQ** and the first frequency digit will be boxed (see below).
- Use the encoder to change the boxed digit and press **SELECT** to change which digit is boxed.
- Press **SAVE** to save the change or **BACK** to cancel.

BACK	T1	Power :	100mW	Select →	SAVE	T1	Power :	100mW	Up →		
		Freq :	496.000					Freq :		496.000	← Down
		Status:	Enabled					Status:		Enabled	

- To change the status, select **STATUS**.
- Use the encoder to change the status (Enabled or Disabled).
- Press **SAVE** to save the change or **BACK** to cancel.

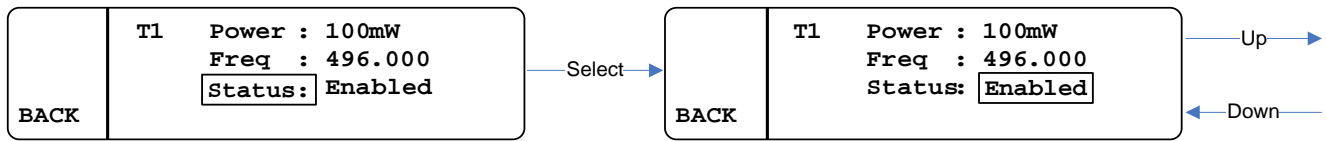

NOTE: For operation under Part 15 of FCC Rules, the maximum transmitter power is 50mW. Higher power requires a license under Part 74 of the FCC Rules.

LOCAL HEADSET OPTIONS

There are two local headset options: **STATUS** and **EARPHONES**.

The **STATUS** setting allows the local headset to be disabled, set up as listen only, or as a fully functioning headset (talk and listen).

The **EARPHONE** setting controls where the receiver audio gets routed: to the left and/or right earphones.

If **SEPARATE** is selected, audio from Intercom 1 will be routed to the right earphone and audio from Intercom 2 will be routed to the left earphone.

If **COMBINED** is chosen, audio from both Intercoms will be routed to both earphones.

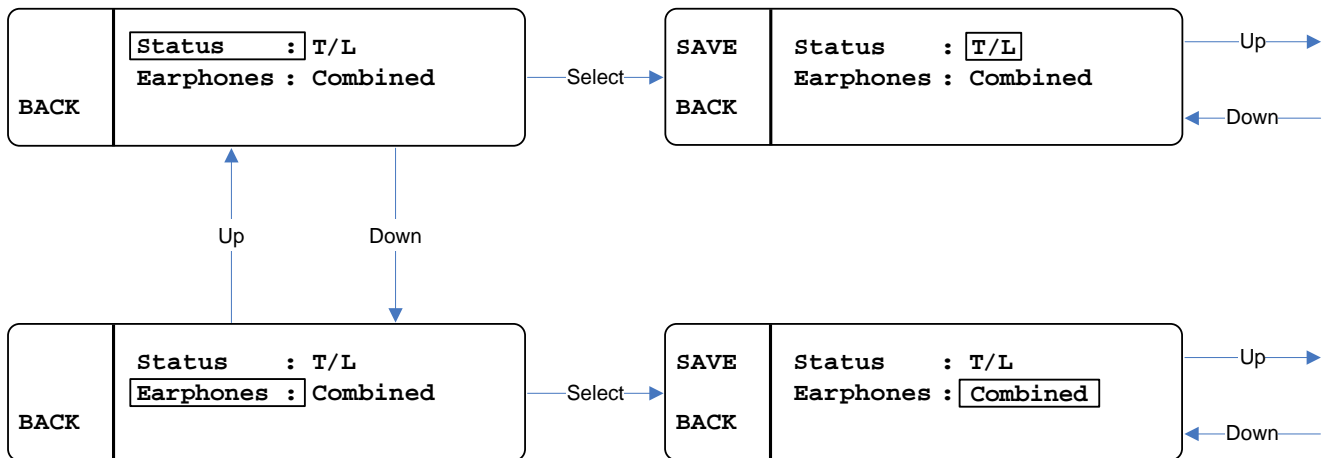

DISPLAY SETTINGS

Blackout Mode

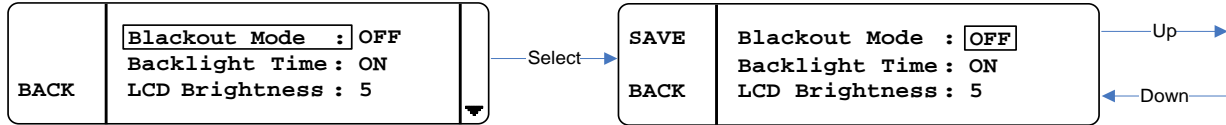

Blackout Mode allows the user to disable all the LEDs on the Base Station.

- From the home screen, press **MENU**, scroll down to **Display Settings** and press **SELECT**.

Blackout mode is the first display setting. There are four options: **OFF**, **LEDs**, **BLGHT** (backlight), and **ON**.

ON means that both the backlight and LEDs will be disabled.

OFF means that both the backlight and LEDs operate normally.

LEDs means that just the LEDs will be disabled or blacked out.

BLGHT means that just the backlight will be disabled or blacked out.

- To change the blackout mode, press **SELECT** and then turn the encoder as shown above.
- Press the **SAVE** button to save the change or press **BACK** to ignore it.

Backlight Time

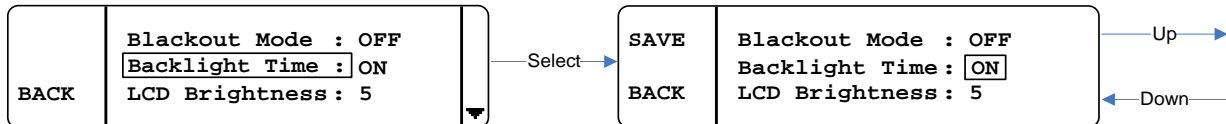

The Backlight Time setting changes the amount of time the backlight stays on for.

- From the home screen, press **MENU**, scroll down to **DISPLAY SETTINGS** and press **SELECT**.

Backlight time is the second display setting. Each time any button is pressed or the encoder is turned the backlight timer gets reset.

Options:

5S for 5 seconds

10S for 10 seconds

20S for 20 seconds

30S for 30 seconds

60S for 60 seconds

ON meaning it will never turn off.

- To change the backlight time, press **SELECT**.
- Turn the encoder as shown above.
- Press **SAVE** to save the change or **BACK** to ignore it.

LCD Brightness

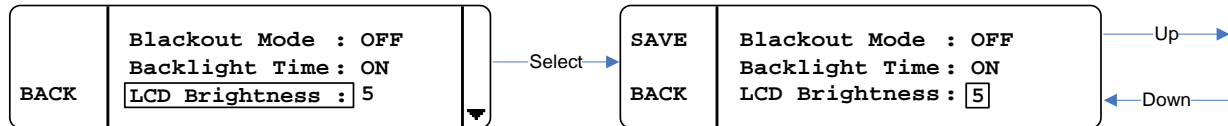

The LCD brightness setting changes the brightness of the LCD's backlight.

- From the home screen, press **MENU**, scroll down to **Display Settings** and press **SELECT**.

LCD Brightness is the third display setting. The choices are 1 – 5, with 1 being dim and 5 being the brightest.

- To change the brightness, press **SELECT**.
- Turn the encoder as shown above.
- Press **SAVE** to save the change or press **BACK** to ignore it.

NOTE: The brightness updates in real time as it is modified.

LCD Contrast

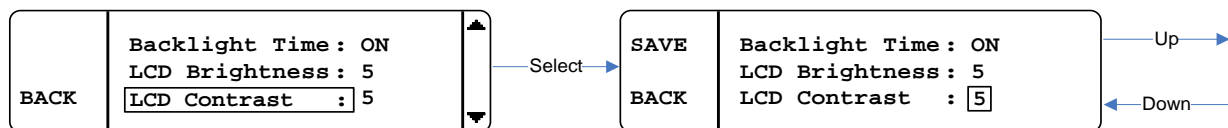

The LCD contrast setting changes the display's contrast.

- To get to the LCD contrast screen, from the home screen, press **MENU**, scroll down to **DISPLAY SETTINGS** and press **SELECT**.

LCD contrast is the fourth display setting. The choices are 1 – 11, with 1 being the dimmest and 11 being the brightest.

- To change the contrast, press **SELECT**.
- Turn the encoder as shown above.
- Press **SAVE** to save the change or press **BACK** to ignore it.

NOTE: The contrast updates in real time as it is modified.

LED Brightness

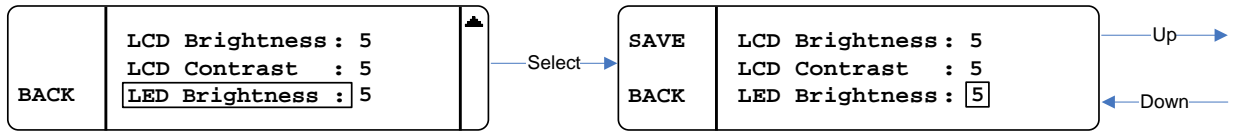

The LED brightness setting changes the talk buttons LED's brightness.

- To get to the LED brightness screen, from the home screen, press **MENU**, scroll down to **Display Settings** and press **SELECT**.

LED brightness is the last display setting. The choices are 1 – 5, with 1 being the dimmest and 5 being the brightest.

- To change the brightness, press **SELECT**.
- Turn the encoder as shown above.
- Press **SAVE** to save the change or press **BACK** to ignore it.

NOTE: the brightness updates in real time as it is modified.

BASE STATION LINK MODES

- To change the Base Station link mode, go to **LINK SETTINGS** in the menu, and press **SELECT**.
- Turn the encoder to the desired setting.
- Press **SAVE**.

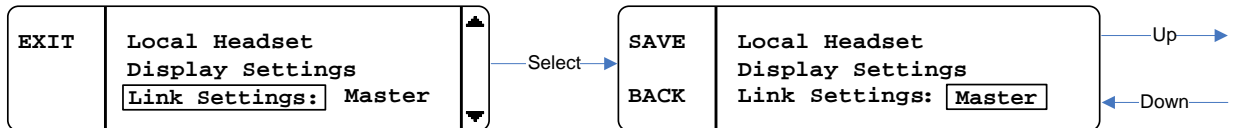

INFO SCREEN

The Info screen displays a version number and serial number of the Base Station. The version number is a composite firmware version number of all the firmware running in the Base Station.

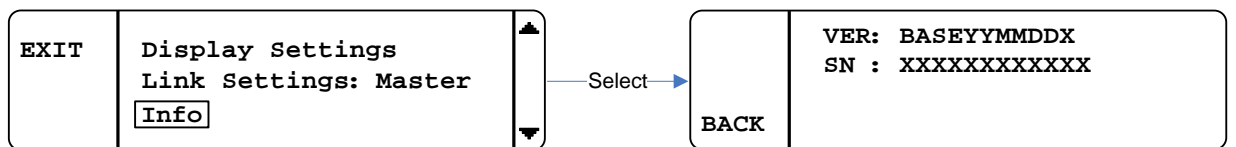

The Info screen is located in the menu right below **LINK SETTINGS**.

- To view the screen, press **SELECT** as shown above.

ENABLING/DISABLING THE PASSCODE

The Menu can be passcode protected. The passcode is a four-digit 0 – 9 number.

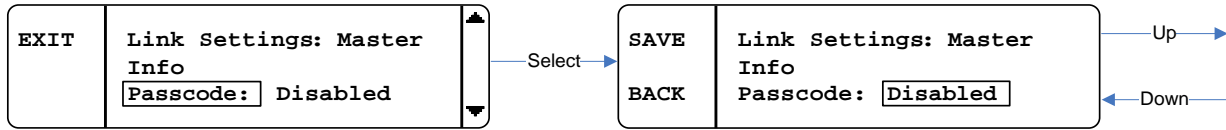

The passcode can be enabled or disabled from the **PASSCODE** screen, located below the **INFO** screen in the Menu as shown above.

- To change the setting, press **SELECT**.
- Turn the encoder until the desired option appears.
- Press **SAVE**.

CHANGING THE PASSCODE

- Select **CHANGE PASSCODE**.
- Enter the desired new passcode (press **SELECT** to advance to the next digit).
- Press **SAVE**.
- Re-enter the desired new passcode.
- Pressing **SAVE** once finished.

If the two passcodes that were just entered match, then the passcode will be changed to that value. If they do not match, then the passcode will remain unchanged.

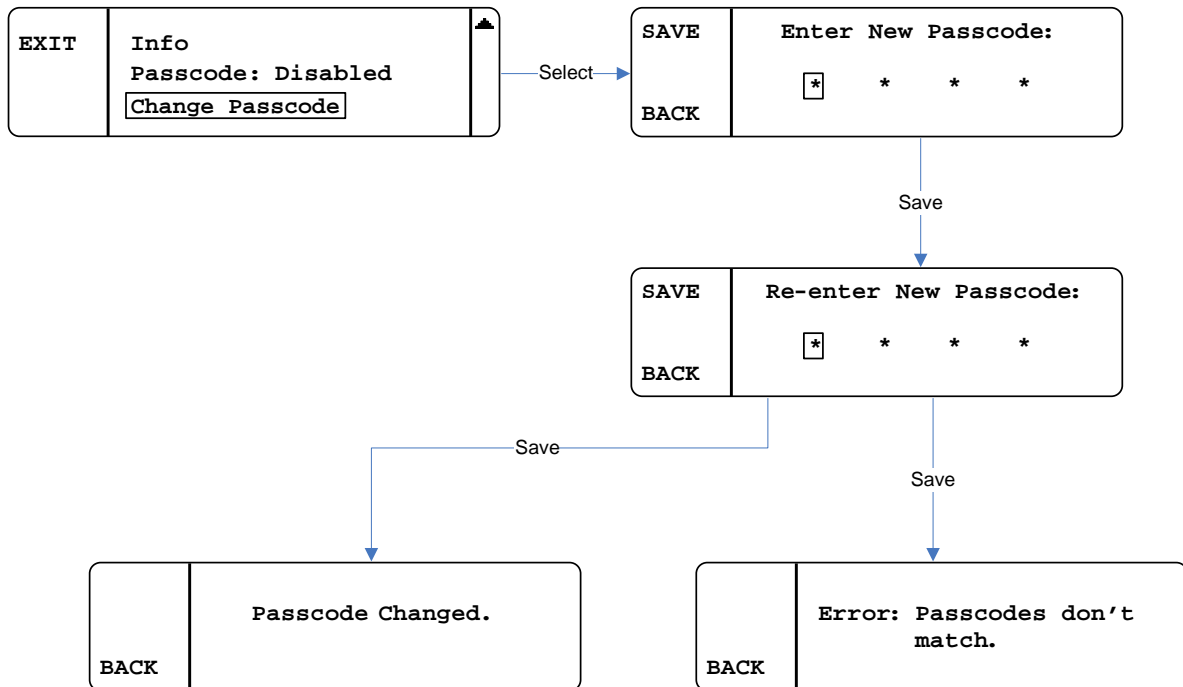

BASE STATION GAIN ADJUSTMENTS

Gain adjustments can be made to the following:

- Intercom inputs and outputs (2W and 4W)
- Auxiliary input and output
- Stage Announce
- Local headset microphone (described in the Local Headset section)

All gains go from 0 – 32 except for the microphone gain goes from 1 – 32. '0' means mute.

- To change one of the gain settings, press the appropriate gain button and then use the encoder to adjust it.

The gain screen will go away after 30 seconds if no button press or encoder knob turn is made.

When changing one of the gains a bar graphic along with a number will be displayed on the screen to show the current setting.

A label telling what gain it is, is also shown.

- Turn the encoder knob clockwise to increase the gain and counter clockwise to decrease the gain. The change will take place immediately.
- When finished, press **SAVE** to save the change, otherwise press **BACK**, or wait for the timeout to cancel any changes (the value will revert back).

INTERCOM 1 & 2

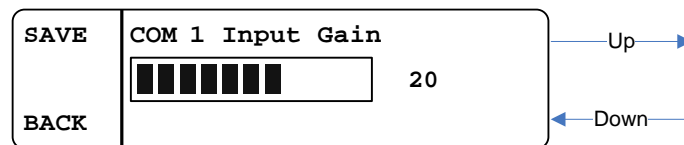

The figure above shows an example of the Intercom gain screen.

AUXILIARY

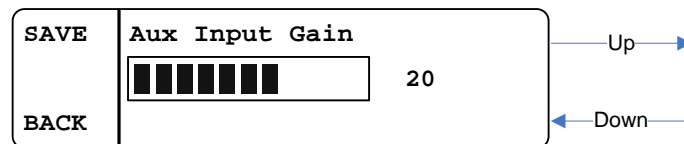

The figure above shows an example of the Auxiliary gain screen.

STAGE ANNOUNCE

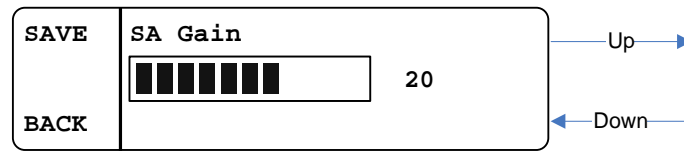

The figure above shows an example of the Stage Announce gain screen.

BASE STATION LOCAL HEADSET

MICROPHONE GAIN

- Change the local headset microphone gain by pressing the **Mic Level** button (below the **Talk** button).

The display will change as shown below.

- Use the encoder to change the gain, and press **SAVE** to save the change or **BACK** to ignore it.

NOTE: The microphone gain updates in real time as it is modified.

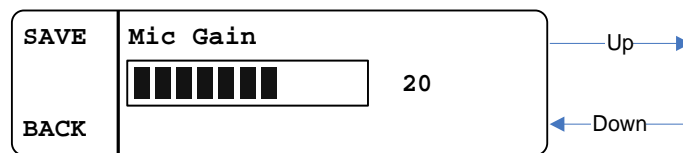

VOLUME

The local headset volume is control by a knob, located to the right of the **TALK** and **MIC** level buttons.

INTERCOM CH1 AND CH2 BUTTONS AND LEDs

These two buttons allow the Base Station user to transmit on Intercom Channel 1, Intercom Channel 2, or both.

When enabled, the audio will be routed through that intercom channel (and not routed when it is disabled).

There are two LEDs above each of these buttons:

- The one on the left is a green LED that is on when that channel is enabled and off when disabled.
- The LED on the right is a red and green LED combo. It is green when that intercom channel's audio is being routed and the talk button is pressed and red when this is true plus the user's microphone is over modulating.

TALK BUTTON

The Talk button allows the Base Station user to talk on the Intercoms. The button can be pressed and held or "tapped" to latch on and off.

BELT PACK OPERATION

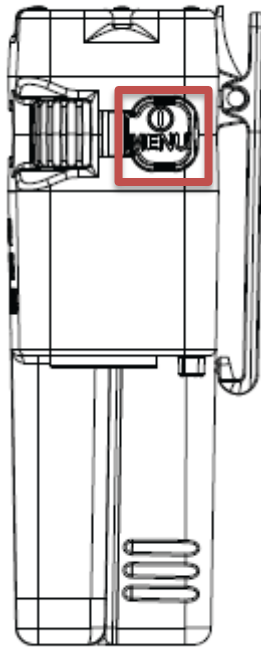

Figure 8 Belt Pack Power Button

BATTERY

Before the Belt Pack is turned on, be sure to attach a fresh battery pack. During operation, the battery indicator will display the battery status at the home screen.

POWERING UP

To turn the Belt Pack on, press the power button as shown in Figure 8 above. While the Belt Pack is powering on, a splash screen will be displayed.



Once the Belt Pack is ready for use, the home screen will be displayed.

POWERING DOWN

To turn the Belt Pack off, press and hold (approximately 3 seconds) the power button until the LCD screen goes blank.

HOME SCREEN

The Belt Pack home screen consists of button labels in the four corners of the display (each corresponding to one of the four transmit buttons), a signal meter, battery indicator, and transmit status indicators. Below is an example of the Belt Pack home screen.

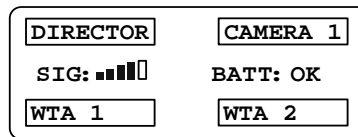

TALK BUTTONS AND LEDs

The Belt Pack has four talk buttons with a corresponding set of green and red LEDs. All four button labels are programmable. The base station controls the routing.

The routing choices for all four buttons are:

- No Route (Mute)
- Intercom Channel (CH) 1
- Intercom Channel (CH) 2
- Intercom Channels (CH) 1 & 2
- Wireless-Talk-Around (WTA) 1
- Wireless-Talk-Around (WTA) 2
- Wireless-Talk-Around (WTA) 1 & 2
- Stage Announce (SA)
- Stage Announce (SA) + Wireless-Talk-Around (WTA) 1
- Stage Announce (SA) + Wireless-Talk-Around (WTA) 2
- Stage Announce (SA) + Wireless-Talk-Around (WTA) 1 & 2
- Auxiliary Out (Aux Out)
- Auxiliary Out (Aux Out) + Wireless-Talk-Around (WTA) 1
- Auxiliary Out (Aux Out) + Wireless-Talk-Around (WTA) 2
- Auxiliary Out (Aux Out) + Wireless-Talk-Around (WTA) 1 & 2

The home screen displays button labels in the four boxes in the corners of the screen.

Each talk button has a green and red LED set.

The green LED turns on to show that the transmitter is active.

The red LED turns on when microphone over modulation occurs while transmitting.

TRANSMIT STATUS INDICATORS

The Belt Pack home screen will display the status of the transmitter. When the transmitter is active, a boxed 'T' will appear on the screen next to the label for that button.

Below are some examples.

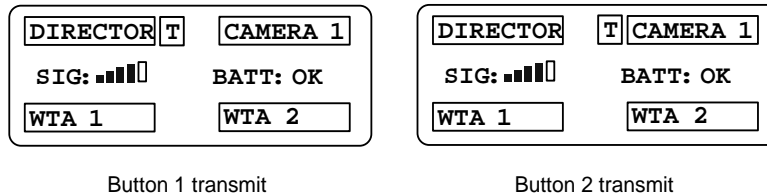

SIGNAL AND BATTERY INDICATORS

The signal meter displays an average of the signal strength of both receivers (Rx1 and Rx2) if both are enabled. If only a single receiver is enabled, the signal meter will display the signal strength of that receiver only.

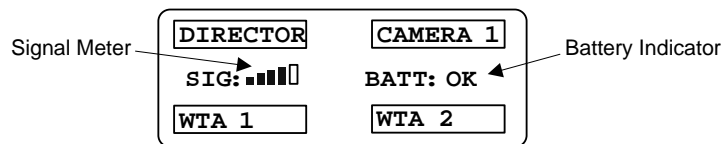

The battery indicator will simply show "BATT: OK" when the battery level is greater than approximately 15%, and "BATT: LOW" when the battery level is below approximately 15%. The low battery threshold depends on the battery type and is automatically detected by the Belt Pack.

HEADSET VOLUME

The headset volume is changeable via the two rotary encoders (see Figure 5):

- Left adjusts volume on Channel One
- Right adjusts volume on Channel Two

If master volume is enabled, both encoders change the volume of both channels. The ratio between the channels is configurable. See the Master Volume section.

POWER / MENU BUTTON

This button is used to turn on and off the Belt Pack, as well as to get into and out of the menu.

- When the Belt Pack is off, press the button to turn it on.
- When on, press and hold (approximately 3 seconds) to turn it off.
- To get into or out of the menu, when the Belt Pack is on, press (without holding) the button.

BELT PACK MENU STRUCTURE

DISPLAY SETTINGS

- From the home screen, press the **MENU** button. The screen will appear as follows:

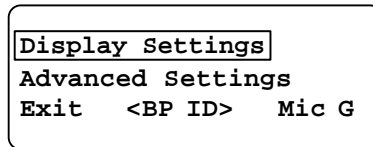

- Press **SELECT**.

Blackout Mode

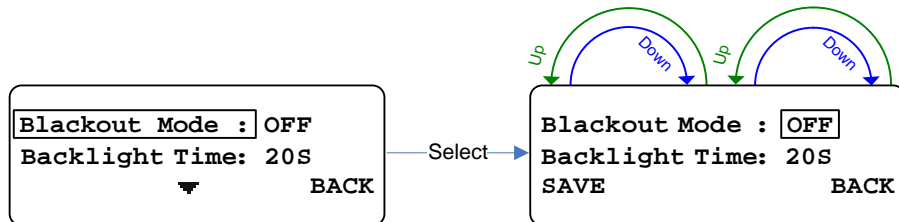

Blackout mode is the first display setting. It allows the LCD backlight and/or the talk LEDs to be disabled or “blacked out.”

There are four options: **OFF**, **LEDs**, **BLGHT** (backlight), and **ON**.

ON: both the backlight and LEDs will be disabled.

OFF: both the backlight and LEDs will operate normally.

LEDs: LEDs will be disabled or blacked out.

BLGHT: backlight will be disabled or blacked out.

- To change the blackout mode, press **SELECT**.
- Turn either encoder as shown above.
- Press **SAVE** to save the change or **BACK** to ignore it.

Backlight Time

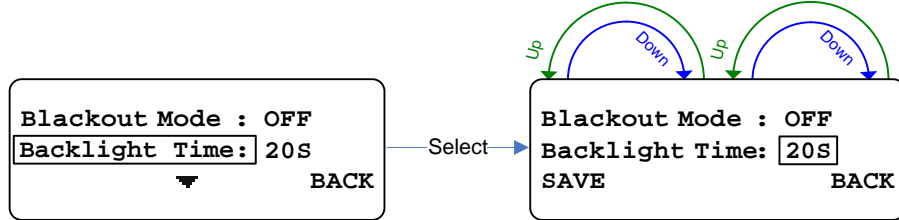

The backlight time setting changes the amount of time the backlight stays on.

Each time any button is pressed or encoder is turned the backlight timer gets reset.

Options:

- 5S** for 5 seconds
- 10S** for 10 seconds
- 20S** for 20 seconds
- 30S** for 30 seconds
- 60S** for 60 seconds
- ON** meaning it will never turn off.

- To change the backlight time, press **SELECT**.
- Turn either encoder as shown above.
- Press **SAVE** to save the change or **BACK** to ignore it.

LCD Brightness

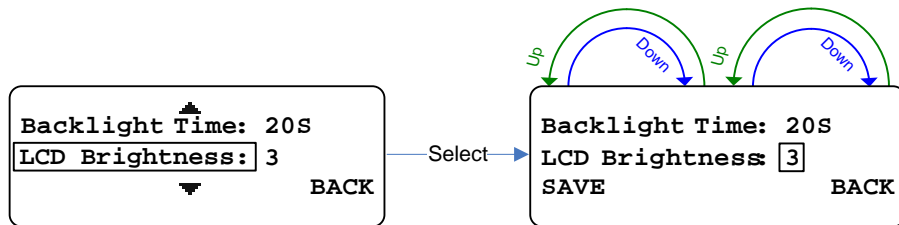

The LCD brightness setting changes the brightness of the LCD's backlight.

The choices are 1 – 5, with 1 being the dimmest and 5 being the brightest.

- To change the brightness, press **SELECT**.
- Turn either encoder as shown above.
- Press **SAVE** to save the change or **BACK** to ignore it.

NOTE: Brightness updates in real time as it is modified.

LCD Contrast

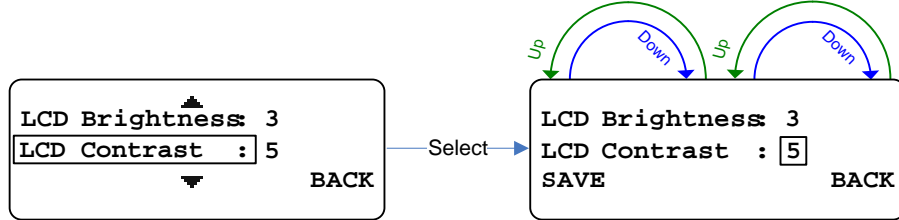

The LCD contrast setting changes the display's contrast.

The choices are 1 – 11, with 1 being the dimmest and 11 being the brightest.

- To change the contrast, press **SELECT**.
- Turn either encoder as shown above.
- Press **SAVE** to save the change or **BACK** to ignore it.

NOTE: The contrast updates in real time as it is modified.

LED Brightness

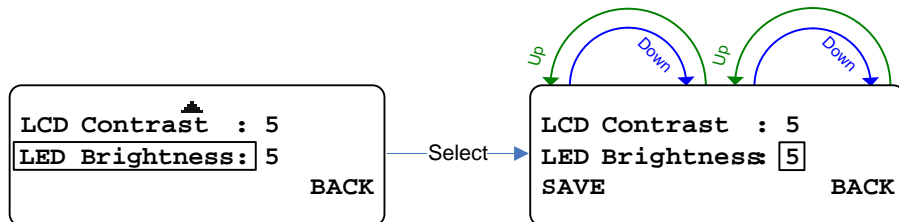

The LED brightness setting changes the talk buttons LED's brightness.

The choices are 1 – 5, with 1 being the dimmest and 5 being the brightest.

- To change the brightness, press **SELECT**.
- Turn either encoder as shown above.
- Press **SAVE** to save the change or **BACK** to ignore it.

NOTE: The brightness updates in real time as it is modified.

ADVANCED SETTINGS

To get to the advanced settings, from the home screen, press the **MENU** button.

- Use either encoder to scroll down to **ADVANCED SETTINGS**.
- The screen will appear as follows:

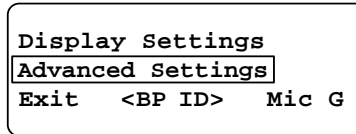

- Once it is boxed, press **SELECT**.

Passcode Protection

The advanced settings menu can be passcode protected.

When the passcode is enabled, once the user presses select on **ADVANCED SETTINGS**, the screen will appear as follows:

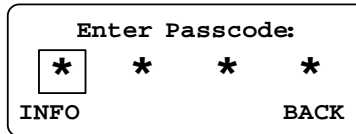

The passcode is four digits where each digit can be any 0 – 9 number.

- Use either encoder to change the selected digit.
- Press **SELECT** to change the selected (boxed) digit.
- Once the last digit is entered press **SELECT**.

If the entered passcode is correct the Belt Pack will go to the advanced settings.

If it is incorrect **Invalid Passcode** will be display for three seconds before returning to the main menu.

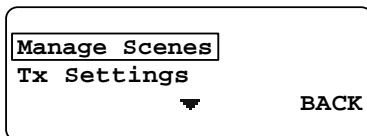

Passcode correct,
Advanced Settings

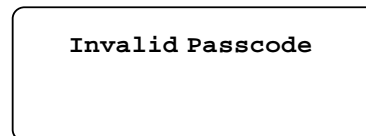

Passcode incorrect

See **ENABLING/DISABLING THE PASSCODE** and/or **CHANGING THE PASSCODE** for more information.

MANAGE SCENES

Scenes provide a way to store multiple configurations, and then easily recall them when needed. Most user configurable settings are included in scenes except for the display settings, the passcode, the Belt Pack ID, and the button labels list.

Manage Scenes is located at the top of the **ADVANCED SETTINGS** sub-menu. Manage Scenes allows the user to change the scene, edit scene names, and add and remove scenes.

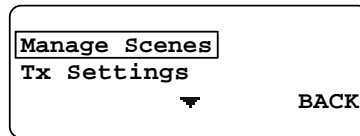

The scene can be changed two different ways, in this menu or by doubling tapping the home screen talk buttons for quick access (if it is setup that way). Here is how the scene is changed in the menu:

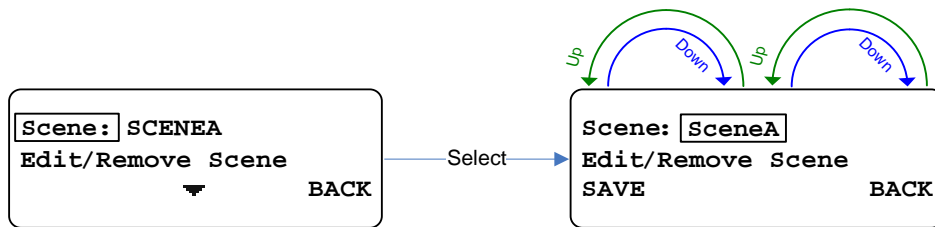

To view the scene list, edit a scene name, or remove a scene, select **Edit/Remove Scene**. The screen will appear as follows:

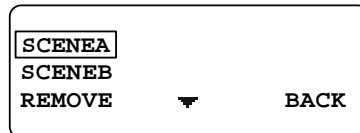

- Use either encoder to scroll through the list.
- Press **SELECT** to edit the currently selected scene name.
 - The left encoder changes the currently selected character.
 - The right encoder changes the group. There are four groups: Upper Case Letters (A-Z), Lower Case Letters (a-z), Numbers (0-9), and Symbols (SYM).
 - Press **SELECT** to change the selected character.
 - Press **SAVE** to save the changes or **BACK** to ignore them.



- Press **REMOVE** to remove the currently selected scene (as long as there is more than one in the list).

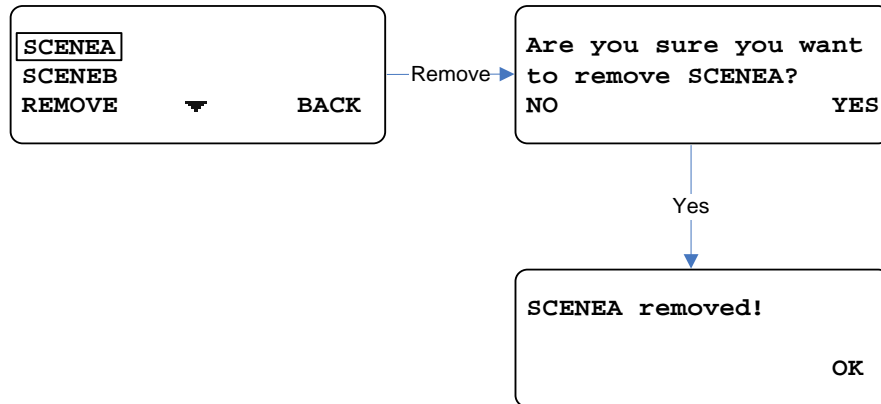

- To add a scene, select **Add New Scene**. This will add a scene to the list. The new scene will copy all parameters from the current scene. Scene names are allowed to be a maximum of six characters.

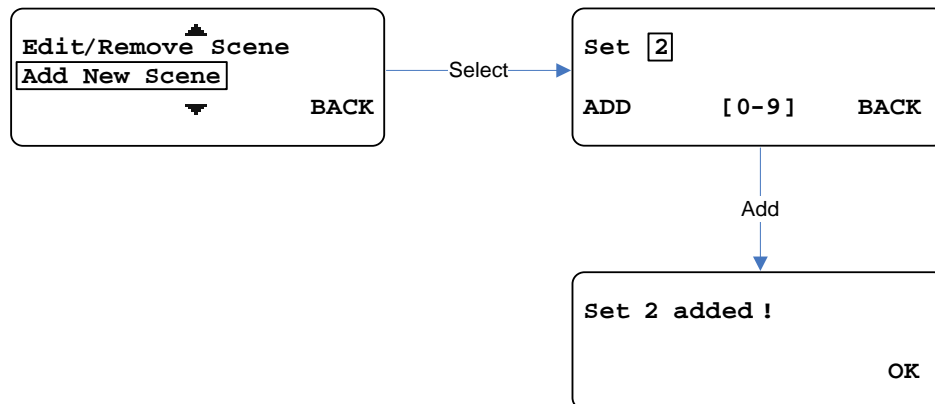

- To setup the home screen talk buttons for scene access, select **Double Tap Access**. Each button, when double tapped, can be configured to either jump to a particular scene, the scene selection menu, or do nothing at all (Disabled option). This allows for a quick and easy way to switch between scenes.

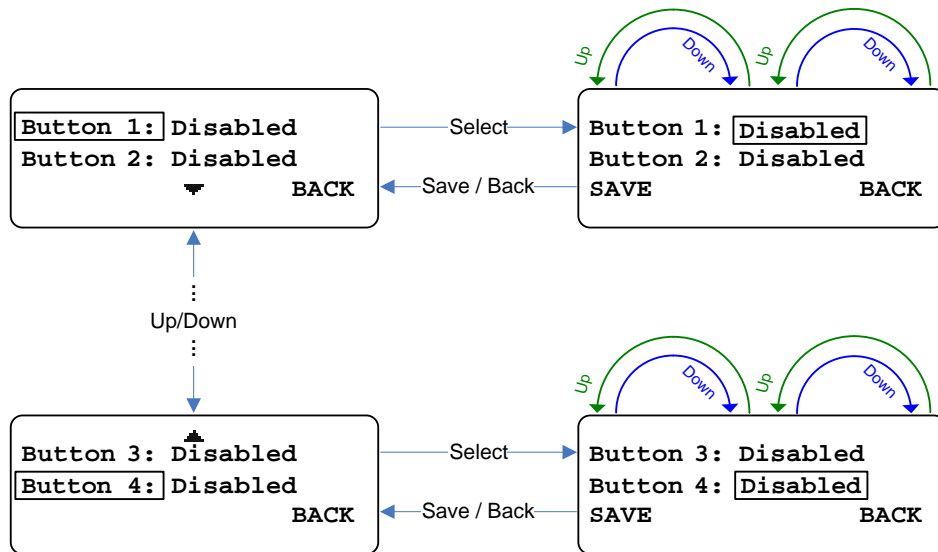

Transmitter Settings

The transmitter settings allow the user to change the transmitter's power level, frequency, and button transmit settings.

The transmitter settings are located in the **ADVANCED SETTINGS** sub-menu.

Once selected, the screen will appear as follows:

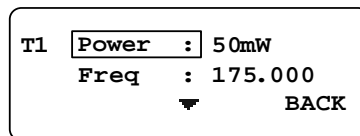

- To change the transmitter power level, press **SELECT**.
- Use either encoder to change the value and press **SAVE** to save or **BACK** to ignore the change.

The choices are 10mW and 50mW.

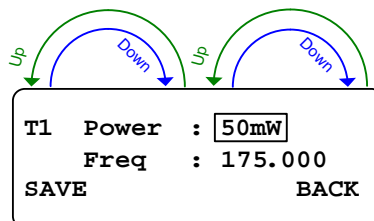

- To change the frequency, scroll down to box **FREQ**: press **SELECT** and the first frequency digit will be boxed (see below).
- Use either encoder to change the boxed digit

- Press **SELECT** to change which digit is boxed.
- Press **SAVE** to save the change or **BACK** to ignore it.

The Belt Pack transmitter frequency range is 174 MHz – 216 MHz (VHF), and the step size is 5 kHz.

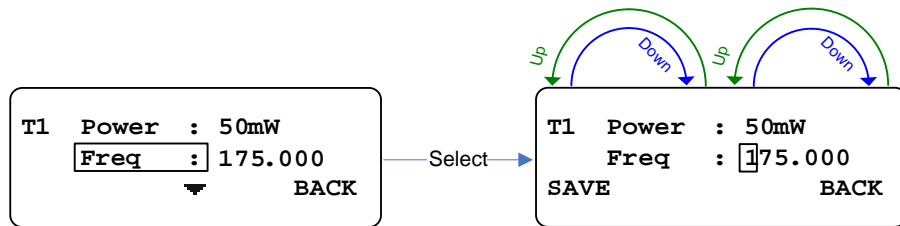

The button transmit settings allow the user to configure how each transmit button works. Each button can be disabled, setup as Push-To-Talk (PTT), or setup to be latchable. If a button is set to latch, it can be pressed and held (PTT) or latched (tapped) on and off.

To change the button transmit settings, scroll down to box **Btn<n> Tx:** and press **SELECT**. Use either encoder to change the value, and press **SAVE** to save or **BACK** to ignore the change. Options for each button are Disabled, Push-To-Talk (PTT), and Latch.

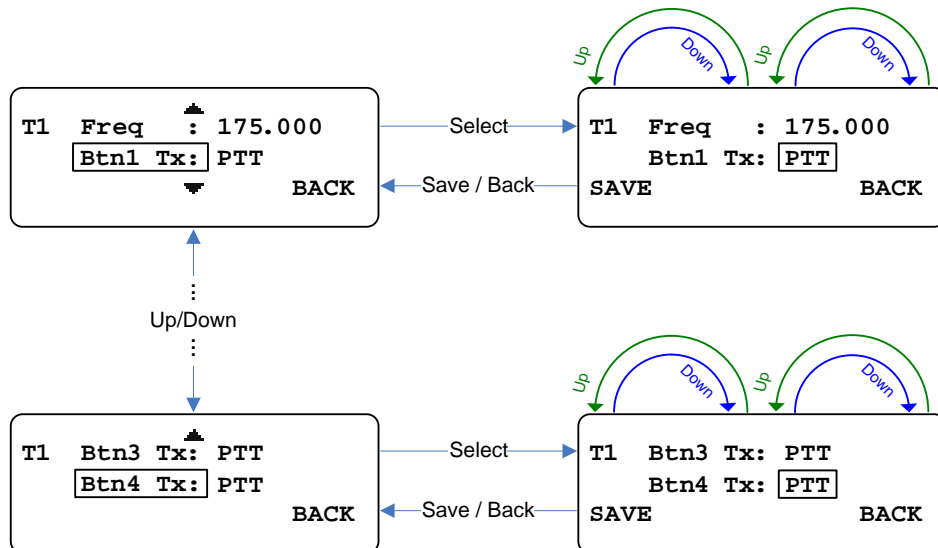

Receiver Settings

The receiver settings allow the user to change the receiver frequencies as well as enable/disable them. The receiver settings are located in the **ADVANCED SETTINGS** sub-menu.

Once selected, the screen will appear as follows:

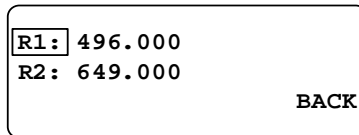

This screen lists the frequency (in MHz) of both receivers as well as the status.

For example, if receiver one is disabled, **R1: Disabled** will be displayed.

If a frequency is listed instead of **Disabled**, then it is enabled and receiving at the specified frequency.

- To change frequency or status, scroll to the receiver you desire to change.
- Press **SELECT** and the screen will change to the following:

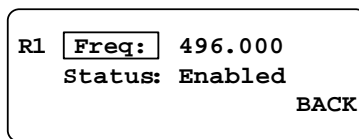

- To change the frequency, press **SELECT** and the first frequency digit will be boxed (see below).
- Use the encoder to change the boxed digit and press **SELECT** to change which digit is boxed.
- Once the frequency has been changed as desired, press **SAVE** to save the change or **BACK** to ignore it.

The Belt Pack receiver frequency range is 470-608MHz and 614-698MHz (UHF).

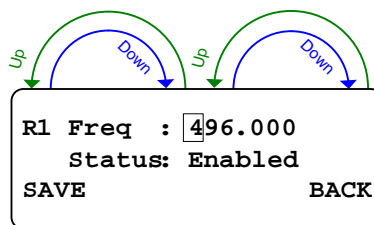

The status enables (turns on) / disabled (turns off) the receiver.

Turn off an un-needed receiver to save battery power.

- To change the status, scroll down to box **Status** and press **SELECT**.
- Turn the encoder to change the selection
- Press **SAVE** to save the change.

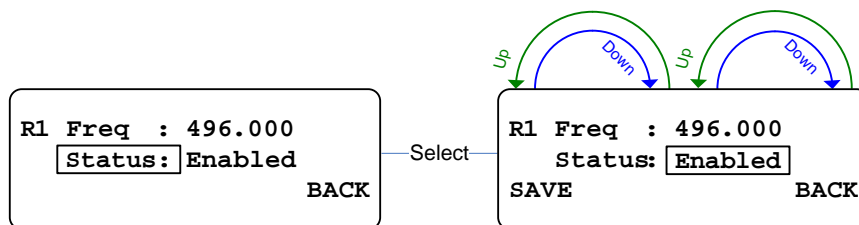

Button Labels

The **Button Labels** menu option in the **Advanced Settings** sub-menu provides a way to change the home screen button labels. This sub-menu allows the user to change, edit, remove, and add new labels. Once the **Button Labels** menu is entered, the screen will appear as follows:



- Press **SELECT** to change labels. Within the new screen:
 - Press **SELECT** to change which label gets changed.
 - Use either encoder to scroll through the list of labels.
 - Press **SAVE** to save changes or **BACK** to ignore them.

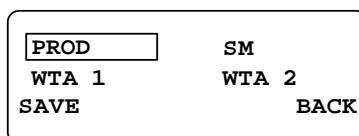

- To view the label list, or edit or remove a label, select the **Edit/Remove Labels** option. The screen will appear as follows:

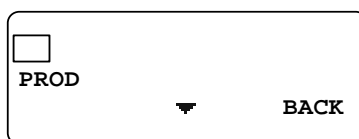

- Use either encoder to scroll through the list.
- Press **SELECT** to edit the currently selected label.
 - The left encoder changes the currently selected character.
 - The right encoder changes the group. There are four groups: Upper Case Letters (A-Z), Lower Case Letters (a-z), Numbers (0-9), and Symbols (SYM).
 - Press **SELECT** to change the selected character.

- Press **SAVE** to save the changes or **BACK** to ignore them.

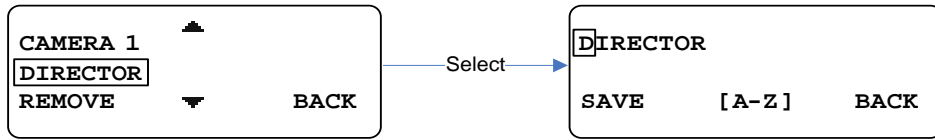

- Press **REMOVE** to remove the currently selected label. Some labels aren't removable. If **REMOVE** is missing on the left soft key, the label isn't removable.

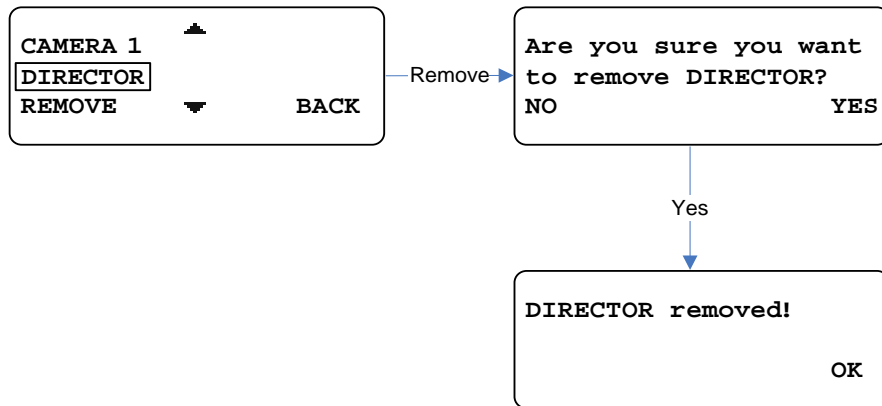

- To add a label to the list, select the **Add New Label** option. Labels are allowed to be a maximum of eight characters, and the controls are the same as editing.

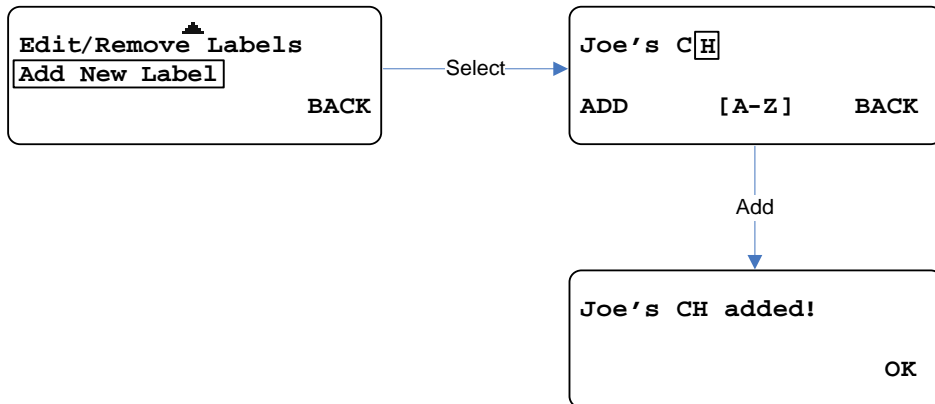

Rx Attenuation

The **Rx Attenuation** menu option in the **Advanced Settings** sub-menu allows the user to set some RF front-end attenuation for the receivers. This parameter can be set to 0dB (default), 5dB, 10dB, 15dB, and 20dB. This applies to both receiver channels.

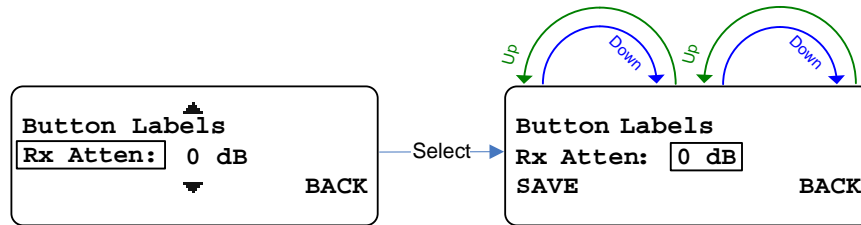

- To change the setting for **Rx Atten**, press **SELECT**.
- Use either encoder to change the parameter.
- When done, press **SAVE** to save the changes or **BACK** to ignore them.

Master Volume

The **Master Volume** menu option in the **Advanced Settings** sub-menu allows the user to set a ratio for the audio levels of both receiver channels that will be heard in the headset. By default, the ratio is 1:1 (CH1 = CH2). This parameter can be adjusted in 2dB increments, up to a maximum of 12dB.

When the **Status** is set to **Disabled**, the volume controls will be independent for each channel.

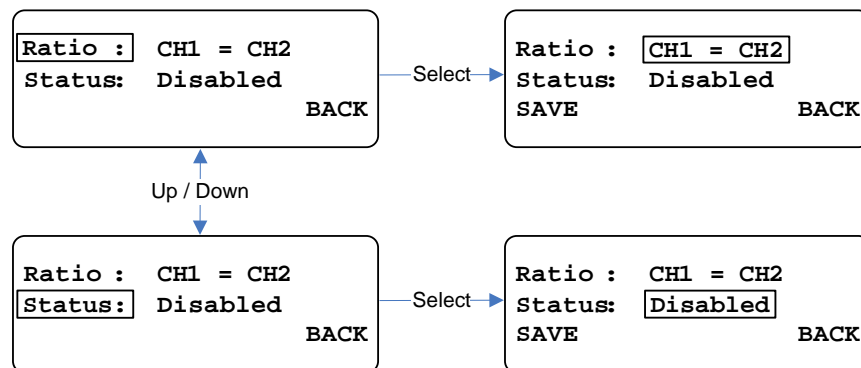

- To change the setting for **Ratio** or **Status**, press **SELECT**
- Use either encoder to change the parameter.
- When done, press **SAVE** to save the changes or **BACK** to ignore them.

Headset Options

There are two local headset options: **Combined** or **Separate**.

This setting controls where the receiver audio gets routed, to the left and/or right earphone.

If **Separate** is selected, audio for Receiver 1 will be routed to the left earphone and audio for Receiver 2 will be routed to the right earphone.

If **Combined** is chosen, audio for both receivers will be routed to both earphones.

Note: if only one receiver is enabled then audio to that receiver will be routed to both earphones no matter what headset option is chosen.

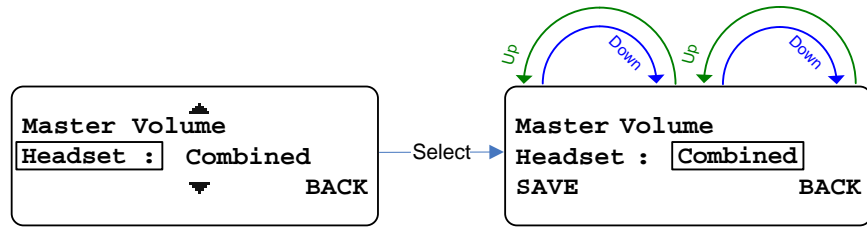

The headset setting is located under the **Advanced Settings** sub-menu right below **Master Volume** as shown above.

- To change the setting, press **SELECT**.
- Turn the encoder until the desired option appears.
- Press **SAVE**.

Minimum Volume

The **Minimum Volume** menu option in the **Advanced Settings** sub-menu allows the user to set a minimum volume level for the headset audio. This range for this parameter is 0-32.

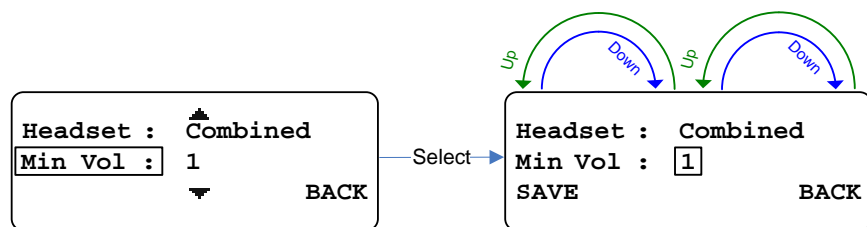

- To change the setting for **Min Vol**, press **SELECT**.
- Use either encoder to change the parameter.
- When done, press **SAVE** to save the changes or **BACK** to ignore them.

Belt Pack ID

The **Belt Pack ID** menu option in the **Advanced Settings** sub-menu allows the user to set a unique identifier for that Belt Pack. The ID can be a maximum of six characters.

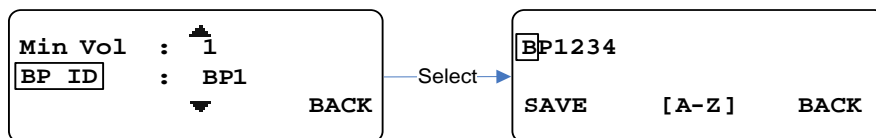

- To change the ID, press **SELECT**.
- The left encoder changes the currently selected character.
- The right encoder changes the group.

- There are four groups: Upper Case Letters (A-Z), Lower Case Letters (a-z), Numbers (0-9), and Symbols (SYM).
- When finished, press **SAVE** to save the changes or **BACK** to ignore them.

Info Screen

The Info screen displays the firmware version number, serial number, and model number of the Belt Pack. The version number is a composite firmware version for all devices.

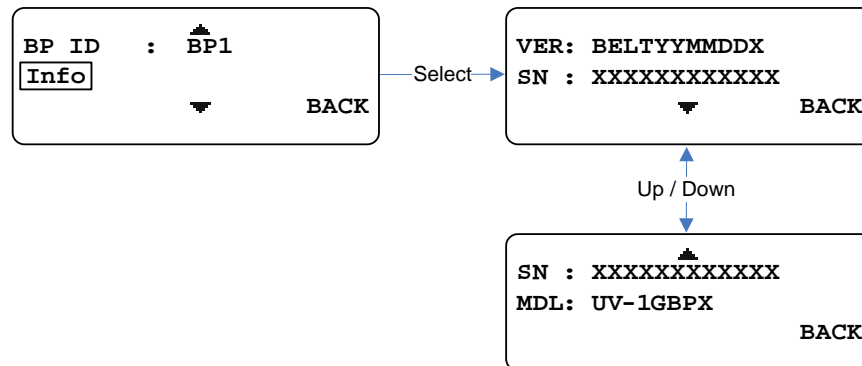

The Info screen is located under the **ADVANCED SETTINGS** sub-menu right below **BP ID**.

- To view the screen, press **SELECT** as shown above.

Enabling/Disabling the Passcode

The **PASSCODE** screen enables or disables the **ADVANCED SETTINGS** sub-menu passcode.

The passcode is a four-digit decimal number (0 – 9).

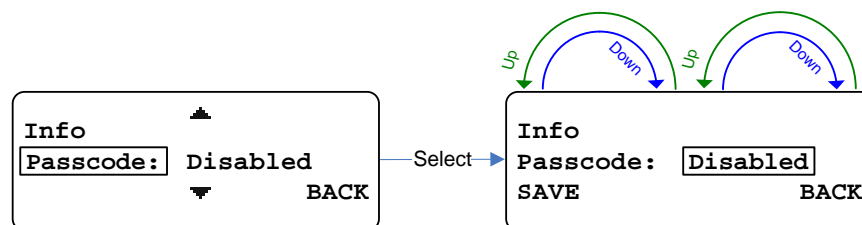

To enable/disable passcode, access the **ADVANCED SETTINGS** sub-menu.

- Select **PASSCODE**.
- To change the setting, press **SELECT**.
- Turn the encoder until the desired option appears.
- Press **SAVE**.

Changing the Passcode

To change passcode, access the **ADVANCED SETTINGS** sub-menu.

- Select **CHANGE PASSCODE**.
- Enter the desired new passcode (press **SELECT** to advance to the next digit).
- Press **SAVE**.
- Re-enter the desired new passcode.
- Press **SAVE** once finished.

If the two passcodes that were just entered match, then the passcode will be changed to that value.

If they don't match, then the passcode will remain unchanged.

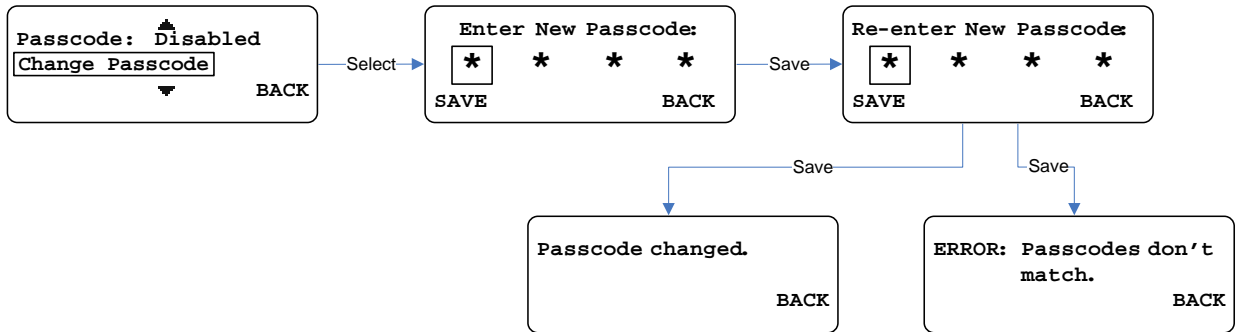

Low Battery Tone

The **Low Battery Tone** menu option in the **Advanced Settings** sub-menu allows the user to enable or disable the battery tone that is heard in the headset when there is a low battery.

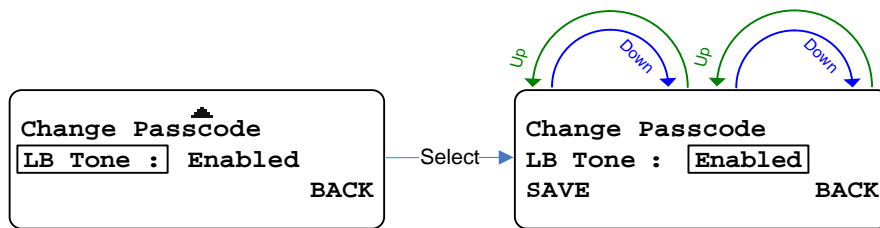

- To change the setting for **LB Tone**, press **SELECT**.
- Use either encoder to change the value.
- Press **SAVE** to save the change or **BACK** to ignore it.

MICROPHONE GAIN

To change the headset microphone gain, access the Menu from the Home Screen.

- Press the right soft key showing **MIC G**.

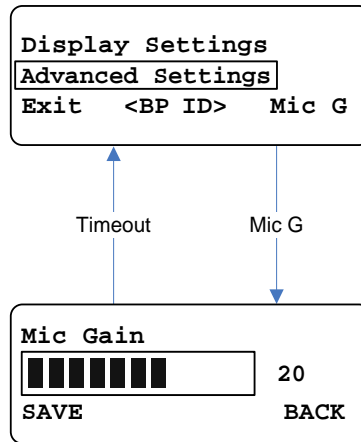

- Use either encoder to change the value.

The bar graphic (1-11) and a number (1-32) will show the current value of the microphone gain. The gain is “live” meaning it will change as the user changes it.

- Press **SAVE** to save the change, and **BACK** to ignore any changes and return to the menu

OVERVIEW

The Radio Active Designs UV-1G PC Application provides the user with ability to update and inspect the configuration of the Base Station or Belt Pack. Additionally, it provides the ability to update the firmware in 1G devices. The communication between the Base Station or Belt Pack and UV-1G PC application utilizes USB. The application allows the user the ability to save and load an unlimited number of configurations.

CONFIGURING THE BASE STATION

Base Station Tab configures a single Base Station.

CONFIGURING THE BELT PACKS

Belt Packs Tab configures up to six Belt Packs.

PASSCODES

Passcodes dialog sets and enables passcodes for the Base Station and Belt Packs.

BUTTON LABELS

Button Labels dialog specifies the pick list of button labels for the Belt Packs.

TIPS AND SHORTCUTS

Copy Down Shortcut (Ctrl-D)

To set all receivers to the same settings, change one setting then hold the Ctrl key while pressing D (Ctrl-D). The setting will copy to all the fields below it.

Paste Down Shortcut (Ctrl-V)

To copy frequencies out of an email or other document and paste into the frequency fields, hold the Ctrl key while pressing V (Ctrl-V). If several frequencies are copied, each on a separate line, it is possible to paste them all at once.

Context Sensitive Help Shortcut (F1)

Press the F1 key at any time to bring up context sensitive help for the window, tab, or control being used.

New, Open, Save, Exit Shortcuts

Holding down the Ctrl key while pressing N (Ctrl-N), O (Ctrl-O), or S (Ctrl-S) act as shortcuts to the File menu items New, Open, or Save.

Holding down the Ctrl key while pressing X (Ctrl-X) on Windows or Q (Ctrl-Q) on Macintosh acts as shortcuts to the File menu item to Exit or Quit the software.

Popup Frequencies Menu

Right-clicking on a Frequency field will pop up a Frequency menu to easily copy frequencies entered in the Base Station tab to corresponding fields in the Belt Packs tab

MENUS

THE FILE MENU

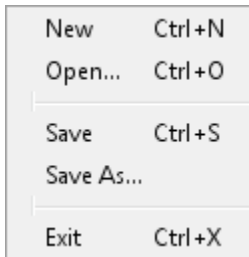

The File menu includes the familiar New, Open, Save, and Save As commands. These pertain to the current configuration which can be saved to a file with the ".uv1g" extension.

The Exit or Quit command exits the software, prompting to save the configuration prior to closing.

THE LOGGING MENU

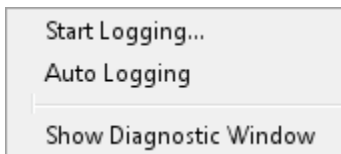

The Start Logging/Stop Logging command enables logging USB communications with the Base Station or Belt Packs to a file. The Save dialog allows selection of the folder and name of the log file.

The Auto Logging command toggles on or off to enable automatic logging to a file, which will prompt the user to choose the folder for the log files.

The Show Diagnostic Window command opens the Diagnostics window displaying the information being logged.

THE CONFIGURE MENU

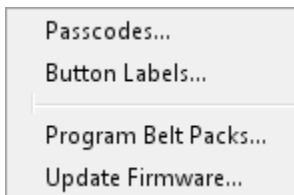

The Passcodes command presents the Passcodes dialog to set and enable passcodes for the Base Station and Belt Packs.

The Button Labels command presents the Button Labels dialog to specify the pick list of button labels for the Belt Packs.

The Program Belt Packs command presents the Write All Belt Packs dialog to quickly program all Belt Packs.

The Update Firmware command presents the Base Station or Belt Pack Firmware Update dialog for the connected device. Normally this dialog will automatically appear as soon as a device is connected that requires an update.

THE SCENES MENU

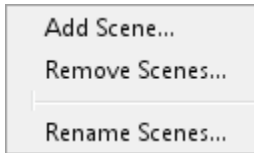

The Scenes menu is invoked either from the menu bar or by right-clicking one of the Scenes drop-downs.

The Add Scene command presents the Add Scene dialog for adding a Scene to one or more Belt Packs.

The Remove Scenes command presents the Remove Scenes dialog for removing one or more Scenes from one or more Belt Packs.

The Rename Scenes command presents the Rename Scenes dialog for renaming any or all Scenes belonging one or more Belt Packs.

THE OPTIONS MENU

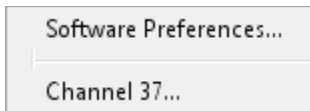

The Software Preferences command presents the Software Preferences dialog.

The Channel 37 command presents the Permit Use of Channel 37 dialog.

THE HELP MENU

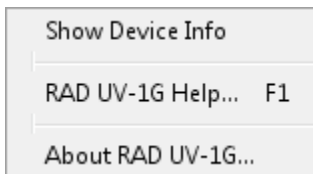

The Show Device Info command presents the Base Station or Belt Pack Info dialogs for all connected devices.

The RAD UV-1G Help command shows the online help system.

The About RAD UV-1G command shows the About Radio Active Designs UV-1G dialog.

THE POPUP FREQUENCIES MENUS

Right-clicking on a Frequency field will pop up a Frequency menu to easily copy frequencies entered in the Base Station tab to corresponding fields in the Belt Packs tab.

Copy All Frequencies to Belt Packs	Copy All Frequencies from Base Station
Copy Rx Frequencies to Belt Packs	Copy Rx Frequencies from Base Station
Copy Tx Frequencies to Belt Packs	Copy Tx Frequencies from Base Station

BASE STATION TAB

The Base Station Tab configuration interface is divided into several sections:

- Receivers:** A table with columns for Receiver (1-6), Frequency, Enabled (checkbox), Squelch, Attenuation, Lock Status, and RSSI.
- Routing:** A table with columns for Receiver (1-6) and four buttons (Button 1-4) with dropdown menus for channel and routing options.
- Transmitters:** A table with columns for Transmitter (1-2), Frequency, Power, Enabled (checkbox), and Lock Status.
- Intercoms:** Settings for Intercom (1-2) including Type, Aux In Routing, and 2 Wire Type.
- Gains:** Settings for Intercom 1, Intercom 2, Auxiliary, and Stage Announce, each with Input and Output Gain dropdowns.
- UI Display Settings:** Settings for Blackout Mode, LCD Backlight, LCD Brightness, LCD Contrast, and LED Brightness, plus a Passcode Enable checkbox.
- Base Station Mode:** A Mode dropdown menu.
- Mic & Headset Settings:** Settings for Gain, Setting, and Mode.

The interface includes the 'RADIO ACTIVE DESIGNS' logo and a 'Program' button at the bottom.

The Base Station Tab includes sections for configuring the Base Station's Receivers, Transmitters, Intercoms, Gains, UI Display Settings, Base Station Mode, and Mic & Headset Settings.

RECEIVERS

The Receivers configuration section displays a table with the following data:

Receiver	Frequency	Enabled	Squelch	Attenuation	Lock Status	RSSI
1	175.000	<input checked="" type="checkbox"/>	0	0dB	==	
2	176.000	<input checked="" type="checkbox"/>	2	10dB	==	
3	177.000	<input checked="" type="checkbox"/>	4	0dB	==	
4	178.000	<input checked="" type="checkbox"/>	5	5dB	==	
5	179.000	<input checked="" type="checkbox"/>	3	15dB	==	
6	180.000	<input checked="" type="checkbox"/>	1	20dB	==	

The receiver settings allow the user to change the receiver frequencies, as well as enabling or disabling them.

Frequency

Belt Pack transmitters and Base Station receivers use the VHF band from 174 to 216 MHz. Enter a frequency from 174.025 and 215.975 MHz, evenly divisible by 5 kHz. Allow at least 25 kHz bandwidth between receivers.

Right-click on a Frequency field to pop up a Frequency menu.

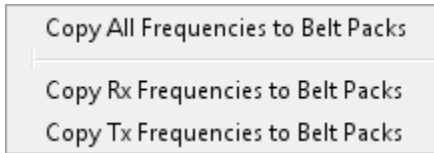

Enabled

A receiver may be disabled if it is not needed.

Squelch

A receiver's squelch may be adjusted between 0 (most sensitive) and 9.

Attenuation

A receiver may be attenuated 0, 5, 10, 15, or 20 dB.

Lock Status and RSSI

While the Base Station is connected, the Lock Status and RSSI are continually updated.

USING SHORTCUT KEYS

CTRL-D (COPY DOWN)

If the user changes one setting and then holds down the Ctrl key while pressing D (Ctrl-D), the setting will be copied down to all the fields below it. This makes it easy to give all receivers the same settings.

CTRL-V (PASTE DOWN)

The user can copy frequencies out of an email or other document and paste them into the frequency fields by holding down the Ctrl key while pressing V (Ctrl-V). If several frequencies are copied, each one on a separate line, the user can paste them all at once.

ROUTING

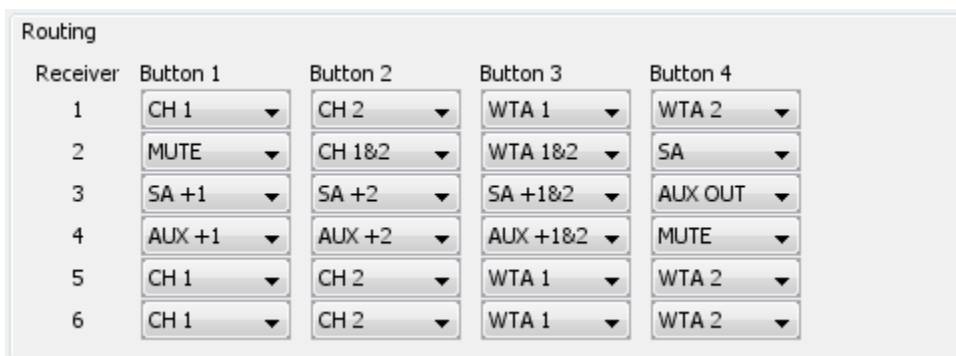

Receiver	Button 1	Button 2	Button 3	Button 4
1	CH 1	CH 2	WTA 1	WTA 2
2	MUTE	CH 1&2	WTA 1&2	SA
3	SA +1	SA +2	SA +1&2	AUX OUT
4	AUX +1	AUX +2	AUX +1&2	MUTE
5	CH 1	CH 2	WTA 1	WTA 2
6	CH 1	CH 2	WTA 1	WTA 2

The routing settings allow the user to route each of the Belt Pack's four transmit buttons separately.

Routing options include Mute, Channel 1, Channel 2, Channel 1 and 2, WTA 1, WTA 2, WTA 1 and 2, SA, SA plus WTA 1, SA plus WTA 2, SA plus WTA 1 and 2, Aux Out, Aux plus WTA 1, Aux plus WTA 2, and Aux plus WTA 1 and 2.

TRANSMITTERS

Transmitter	Frequency	Power	Enabled	Lock Status
1	519.000	20 mW	<input checked="" type="checkbox"/>	..
2	520.000	50 mW	<input checked="" type="checkbox"/>	..

The transmitter settings allow the user to change the transmitter frequencies and power levels, as well as enabling or disabling them.

Frequency

Base Station transmitters and Belt Pack receivers use the UHF band from 470 to 698 MHz. Enter a frequency from 470.025 to 607.975 MHz, or from 614.025 to 697.975 MHz. Below 655 MHz frequencies must be evenly divisible by 10 or 25 kHz. Above 655 MHz frequencies must be evenly divisible by 25 kHz. Allow at least 25 kHz bandwidth between receivers.

Right-click on a Frequency field to pop up a Frequency menu.

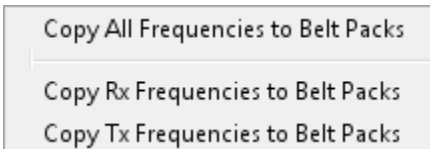

Power

20 mW, 50 mW, 100 mW, or 250 mW.

Enabled

A transmitter may be disabled if it is not needed.

Lock Status

While the Base Station is connected the Lock Status is continually updated.

INTERCOMS

Each Base Station can connect to two intercom systems.

Intercoms		
Intercom	Type	Aux In Routing
1	2 Wire	Global
2	4 Wire	Local
2 Wire Type	Clear-Com	

Intercom Type

Off, 2 Wire, or 4 Wire.

Aux in Routing

The Aux in Routing controls the functionality of the auxiliary input. The three options are

- Off — Aux In will not be routed on the given intercom.
- Local — Aux In will be routed to the wireless intercom and the local headset.
- Global — Aux In will be routed to the wireless intercom, the local headset, and the wired intercom.

2 Wire Type

Clear-Com, Audiocom, or RTS.

GAINS

Gains		
	Input Gain	Output Gain
Intercom 1	28	23
Intercom 2	27	24
Auxiliary	26	25
Stage Announce		22

Configure the input and output gains of the Intercom, Auxiliary, and Stage Announce channels.

Intercom 1 and Intercom 2

Input and Output gains range from 0 (off) to 32 (maximum).

Auxiliary

Input and Output gains range from 0 (off) to 32 (maximum).

Stage Announce

Output gain ranges from 0 (off) to 32 (maximum).

UI DISPLAY SETTINGS

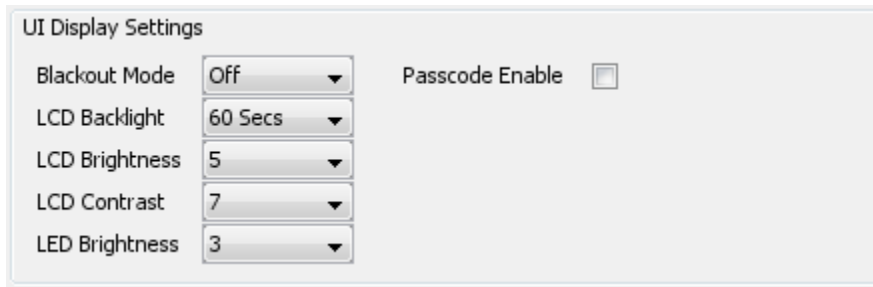

The screenshot shows a configuration window titled "UI Display Settings". It contains the following controls:

- Blackout Mode: A dropdown menu set to "Off".
- Passcode Enable: A checkbox that is currently unchecked.
- LCD Backlight: A dropdown menu set to "60 Secs".
- LCD Brightness: A dropdown menu set to "5".
- LCD Contrast: A dropdown menu set to "7".
- LED Brightness: A dropdown menu set to "3".

Configure the front panel display of the base station.

Blackout Mode

Options are Off (nothing blacked out), LEDs (LEDs blacked out), Backlight (backlight blacked out), and On (everything blacked out).

LCD Backlight

Options to keep the front panel backlight on for 5, 10, 20, 30, or 60 Seconds, or to remain Always On.

LCD Brightness

Options range from 1 (dim) to 5 (bright).

LCD Contrast

Options range from 1 (low) to 11 (high).

LED Brightness

Options range from 1 (dim) to 5 (bright).

PASSCODE ENABLE

If enabled, the user will be required to enter the passcode before making changes via the front panel.

BASE STATION MODE

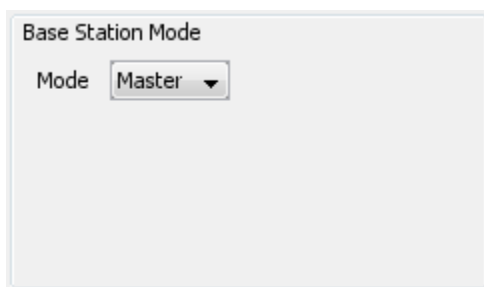

The screenshot shows a configuration window titled "Base Station Mode". It contains a single control:

- Mode: A dropdown menu set to "Master".

Base Link is a method of connecting up to six Base Stations together in order to expand the number of Belt Packs that a system can handle. When two or more Base Stations are linked together, one must be set up as the *Master* and the rest as a *Slave*. The slave Base Station transmitters and wired intercoms will be disabled, but will route wireless Belt Pack audio data to the master unit. In effect, this means that up to 36 Belt Packs can be used in a single wireless two-channel system.

Please refer to the User Manual for additional information.

MIC & HEADSET SETTINGS

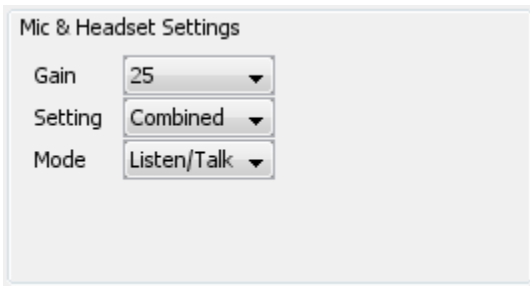

Configure the microphone and headset on the base station.

Gain

Microphone gain ranges from 1 (low) to 11 (high).

Setting

Options are Separate (one channel in one ear, one in the other), and Combined (both channels in both ears).

Mode

Options are Off, Listen and Talk, and just Listen.

PROGRAM BUTTON

Write all current settings to the Base Station connected to the USB port.

BASE STATION CONNECTED

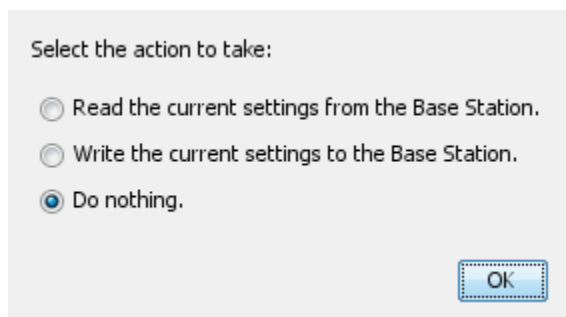

When a Base Station is connected via USB, select one of the following actions:

Read from the Base Station.

All of the Base Station's current settings will be read into the Base Station Tab.

Write to the Base Station.

All of the Base Station Tab's current settings will be written (programmed) into the Base Station.

Do nothing.

No action will be taken.

BELT PACKS TAB

Belt Pack Id	Scene	Receiver One Frequency	Receiver One Enable	Receiver One Lock	Receiver One RSSI	Receiver Two Frequency	Receiver Two Enable	Receiver Two Lock	Receiver Two RSSI	Receiver Attenuation	Button Labels Button 1	Button 2	Button 3	Button 4
Belt 1	Stage	519.000	<input checked="" type="checkbox"/>	<input type="checkbox"/>	...	520.000	<input checked="" type="checkbox"/>	<input type="checkbox"/>	...	0dB	CH 1	CH 2	WTA 1	WTA 2
Belt 2	Stage	519.000	<input checked="" type="checkbox"/>	<input type="checkbox"/>	...	520.000	<input checked="" type="checkbox"/>	<input type="checkbox"/>	...	0dB		CH 1&2	WTA 1&2	SA
Belt 3	Stage	519.000	<input checked="" type="checkbox"/>	<input type="checkbox"/>	...	520.000	<input checked="" type="checkbox"/>	<input type="checkbox"/>	...	0dB	SA +1	SA +2	SA +1&2	AUX OUT
Belt 4	Stage	519.000	<input checked="" type="checkbox"/>	<input type="checkbox"/>	...	520.000	<input checked="" type="checkbox"/>	<input type="checkbox"/>	...	0dB	AUX +1	AUX +2	AUX +1&2	
Belt 5	Stage	519.000	<input checked="" type="checkbox"/>	<input type="checkbox"/>	...	520.000	<input checked="" type="checkbox"/>	<input type="checkbox"/>	...	0dB	CH 1	CH 2	WTA 1	WTA 2
Belt 6	Stage	519.000	<input checked="" type="checkbox"/>	<input type="checkbox"/>	...	520.000	<input checked="" type="checkbox"/>	<input type="checkbox"/>	...	0dB	CH 1	CH 2	WTA 1	WTA 2

Belt Pack Id	Transmitter Frequency	Power	Lock	Button Action Button 1	Button 2	Button 3	Button 4	Double Tap Action Button 1	Button 2	Button 3	Button 4	Battery Settings Tone	Type	Level
Belt 1	175.000	50 mW	<input type="checkbox"/>	PTT	PTT	PTT	PTT	Stage	BackLt	Stores	Disabled	<input checked="" type="checkbox"/>	AA
Belt 2	176.000	50 mW	<input type="checkbox"/>	PTT	PTT	PTT	Latch	Stage	Stores	Stores	Disabled	<input checked="" type="checkbox"/>	AA
Belt 3	177.000	50 mW	<input type="checkbox"/>	Latch	Latch	Latch	PTT	Stage	BackLt	Stores	Disabled	<input checked="" type="checkbox"/>	AA
Belt 4	178.000	50 mW	<input type="checkbox"/>	PTT	PTT	PTT	PTT	Stage	BackLt	Stores	Disabled	<input checked="" type="checkbox"/>	AA
Belt 5	179.000	50 mW	<input type="checkbox"/>	PTT	PTT	PTT	PTT	Stage	Disabled	Disabled	Disabled	<input checked="" type="checkbox"/>	AA
Belt 6	180.000	50 mW	<input type="checkbox"/>	PTT	PTT	PTT	PTT	Stage	Disabled	Disabled	Disabled	<input checked="" type="checkbox"/>	AA

Belt Pack Id	UI Settings Blackout Mode	LCD Backlight	LCD Brightness	LCD Contrast	LED Brightness	Passcode	Mic & Headset Mic Gain	Earphone Setting	Minimum Volume	Master Volume Ratio	Enable
Belt 1	Off	60 Secs	5	5	3	<input type="checkbox"/>	25	Combined	0	Ch 1 = Ch 2	<input type="checkbox"/>
Belt 2	Off	60 Secs	5	5	3	<input type="checkbox"/>	25	Combined	0	Ch 1 = Ch 2	<input type="checkbox"/>
Belt 3	Off	60 Secs	5	5	3	<input type="checkbox"/>	25	Combined	0	Ch 1 = Ch 2	<input type="checkbox"/>
Belt 4	Off	60 Secs	5	5	3	<input type="checkbox"/>	25	Combined	0	Ch 1 = Ch 2	<input type="checkbox"/>
Belt 5	Off	60 Secs	5	5	3	<input type="checkbox"/>	25	Combined	0	Ch 1 = Ch 2	<input type="checkbox"/>
Belt 6	Off	60 Secs	5	5	3	<input type="checkbox"/>	25	Combined	0	Ch 1 = Ch 2	<input type="checkbox"/>



The Belt Pack Tab contains three sections and each section has six rows, one for each Belt Pack.

TOP SECTION — RECEIVERS AND BUTTON LABELS

Belt Pack Id	Scene	Receiver One Frequency	Receiver One Enable	Receiver One Lock	Receiver One RSSI	Receiver Two Frequency	Receiver Two Enable	Receiver Two Lock	Receiver Two RSSI	Receiver Attenuation	Button Labels Button 1	Button 2	Button 3	Button 4
Belt 1	Stage	519.000	<input checked="" type="checkbox"/>	<input type="checkbox"/>	...	520.000	<input checked="" type="checkbox"/>	<input type="checkbox"/>	...	0dB	CH 1	CH 2	WTA 1	WTA 2
Belt 2	Stage	519.000	<input checked="" type="checkbox"/>	<input type="checkbox"/>	...	520.000	<input checked="" type="checkbox"/>	<input type="checkbox"/>	...	0dB		CH 1&2	WTA 1&2	SA
Belt 3	Stage	519.000	<input checked="" type="checkbox"/>	<input type="checkbox"/>	...	520.000	<input checked="" type="checkbox"/>	<input type="checkbox"/>	...	0dB	SA +1	SA +2	SA +1&2	AUX OUT
Belt 4	Stage	519.000	<input checked="" type="checkbox"/>	<input type="checkbox"/>	...	520.000	<input checked="" type="checkbox"/>	<input type="checkbox"/>	...	0dB	AUX +1	AUX +2	AUX +1&2	
Belt 5	Stage	519.000	<input checked="" type="checkbox"/>	<input type="checkbox"/>	...	520.000	<input checked="" type="checkbox"/>	<input type="checkbox"/>	...	0dB	CH 1	CH 2	WTA 1	WTA 2
Belt 6	Stage	519.000	<input checked="" type="checkbox"/>	<input type="checkbox"/>	...	520.000	<input checked="" type="checkbox"/>	<input type="checkbox"/>	...	0dB	CH 1	CH 2	WTA 1	WTA 2

BELT PACK ID

The ID is displayed briefly when the belt pack's program button is pressed. The ID can be up to six characters in length.

SCENE

Scenes facilitate switching many different settings with one button click.

A Scene consists of all Belt Pack settings except ID, Display, and Passcode settings. Each Belt Pack can store up to 10 different scenes.

Uses the Scenes menu to Add, Remove, and Rename Scenes.

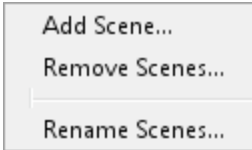

RECEIVER ONE AND RECEIVER TWO

Frequency

Belt Pack receivers and Base Station transmitters use the UHF band from 470 to 698 MHz. Enter a frequency from 470.025 to 607.975 MHz, or from 614.025 to 697.975 MHz. Below 655 MHz frequencies must be evenly divisible by 10 or 25 kHz. Above 655 MHz frequencies must be evenly divisible by 25 kHz. Allow at least 25 kHz bandwidth between receivers.

Right-click on a Frequency field to pop up a Frequency menu.

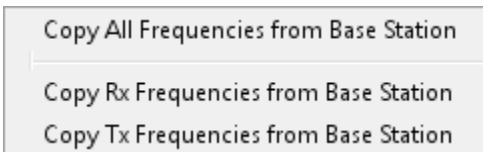

Enable

A receiver may be disabled if it is not needed, but only one of the Belt Pack's two receivers can be disabled.

Lock

While the Belt Pack is connected via USB, the lock status is continually updated.

RSSI

While the Belt Pack is connected via USB, the RSSI is continually updated.

RECEIVER

The Attenuation field applies to both receivers.

Attenuation

Options include 0dB (no attenuation), 5dB, 10dB, 15dB, and 20dB.

Using Shortcut Keys

CTRL-D (COPY DOWN)

If the user changes one setting and then holds down the Ctrl key while pressing D (Ctrl-D), the setting will be copied down to all the fields below it. This makes it easy to give all receivers the same settings.

CTRL-V (PASTE DOWN)

Copy frequencies out of an email or other document and paste them into the frequency fields by holding down the Ctrl key while pressing V (Ctrl-V). If several frequencies are copied, each one on a separate line, the user can paste them all at once.

BUTTON LABELS

Button 1, Button 2, Button 3, Button 4

Labels must be specified in the Button Labels dialog before they will appear in the drop-down lists. See [Button Labels](#) for more information.

MIDDLE SECTION — TRANSMITTER, BUTTON ACTIONS, AND BATTERY SETTINGS

Belt Pack Id	Transmitter			Button Action				Double Tap Action		
	Frequency	Power	Lock	Button 1	Button 2	Button 3	Button 4	Button 1	Button 2	Button 3
Belt 1	175.000	50 mW	==	PTT	PTT	PTT	PTT	Stage	BackLt	Stores
Belt 2	176.000	50 mW	==	PTT	PTT	PTT	Latch	Stage	Stores	Stores
Belt 3	177.000	50 mW	==	Latch	Latch	Latch	PTT	Stage	BackLt	Stores
Belt 4	178.000	50 mW	==	PTT	PTT	PTT	PTT	Stage	BackLt	Stores
Belt 5	179.000	50 mW	==	PTT	PTT	PTT	PTT	Stage	Disabled	Disabled
Belt 6	180.000	50 mW	==	PTT	PTT	PTT	PTT	Stage	Disabled	Disabled

TRANSMITTER

Frequency

Belt Pack transmitters and Base Station receivers use the VHF band from 174 to 216 MHz. Enter a frequency from 174.025 and 215.975 MHz, evenly divisible by 5 kHz. Allow at least 25 kHz bandwidth between receivers.

Right-click on a Frequency field to pop up a Frequency menu.

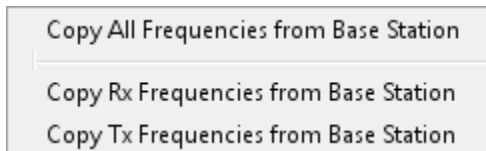

Power

Options include 10 mW and 50 mW.

Lock

While the Belt Pack is connected via USB, the lock status is continually updated.

BUTTON ACTION

Button 1, Button 2, Button 3, Button 4

Options include Disabled, PTT, and Latch.

DOUBLE-TAP ACTION

Button 1, Button 2, Button 3, Button 4

Options include Disabled, Scenes selection, and switch to the selected scene.

BATTERY SETTINGS

Auto Low Reporting

Checked (enabled) or unchecked (ignored).

Type

While the Belt Pack is connected via USB, the battery type is displayed.

Level

While the Belt Pack is connected via USB, the battery level is continually updated.

BOTTOM SECTION — UI SETTINGS, PASSCODE, AND MIC & HEADSET

Belt Pack Id	UI Settings						Mic & Headset			Master Volume		Enable
	Blackout Mode	LCD Backlight	LCD Brightness	LCD Contrast	LED Brightness	Passcode	Mic Gain	Earphone Setting	Minimum Volume	Ratio		
Belt 1	Off	60 Secs	5	5	3	<input type="checkbox"/>	25	Combined	0	Ch 1 = Ch 2	<input type="checkbox"/>	
Belt 2	Off	60 Secs	5	5	3	<input type="checkbox"/>	25	Combined	0	Ch 1 = Ch 2	<input type="checkbox"/>	
Belt 3	Off	60 Secs	5	5	3	<input type="checkbox"/>	25	Combined	0	Ch 1 = Ch 2	<input type="checkbox"/>	
Belt 4	Off	60 Secs	5	5	3	<input type="checkbox"/>	25	Combined	0	Ch 1 = Ch 2	<input type="checkbox"/>	
Belt 5	Off	60 Secs	5	5	3	<input type="checkbox"/>	25	Combined	0	Ch 1 = Ch 2	<input type="checkbox"/>	
Belt 6	Off	60 Secs	5	5	3	<input type="checkbox"/>	25	Combined	0	Ch 1 = Ch 2	<input type="checkbox"/>	

UI SETTINGS

Blackout Mode

Options are Off (nothing blacked out), LEDs (LEDs blacked out), Backlight (backlight blacked out), and On (everything blacked out).

LCD Backlight

Options to keep the front panel backlight on for 5, 10, 20, 30, or 60 Seconds, or to remain Always On.

LCD Brightness

Options range from 1 (dim) to 5 (bright).

LCD Contrast

Options range from 1 (low) to 11 (high).

LED Brightness

Options range from 1 (dim) to 5 (bright).

Passcode

If enabled, the user will be required to enter the passcode before making changes via the menus.

MIC & HEADSET

Mic Gain

The gain can be from 1 to 11.

Earphone Setting

This setting controls where the receiver audio gets routed, to the left and/or right earphone. If Separate is selected, audio for Receiver 1 will be routed to the left earphone and audio for Receiver 2 will be routed to the right earphone. If Combined is chosen, audio for both receivers will be routed to both earphones. Note: if only one receiver is enabled then audio to that receiver will be routed to both earphones no matter what headset option is chosen.

Minimum Volume

Allows the user to set a minimum volume level for the headset audio.

MASTER VOLUME

The Master Volume menu option allows the user to set a ratio for the audio levels of both receiver channels that will be heard in the headset. By default, the ratio is Ch 1 = Ch 2.

Ratio

Ch 1 + 12dB, Ch 1 + 10dB, Ch 1 + 8dB, Ch 1 + 6dB, Ch 1 + 4dB, Ch 1 + 2dB, Ch 1 = Ch 2, Ch 2 + 2dB, Ch 2 + 4dB, Ch 2 + 6dB, Ch 2 + 8dB, Ch 2 + 10dB, Ch 2 + 12dB

Enable

If not selected, the volume controls will be independent for each channel.

PROGRAM

The Program button brings up the Write to Belt Packs dialog.

BELT PACK CONNECTED

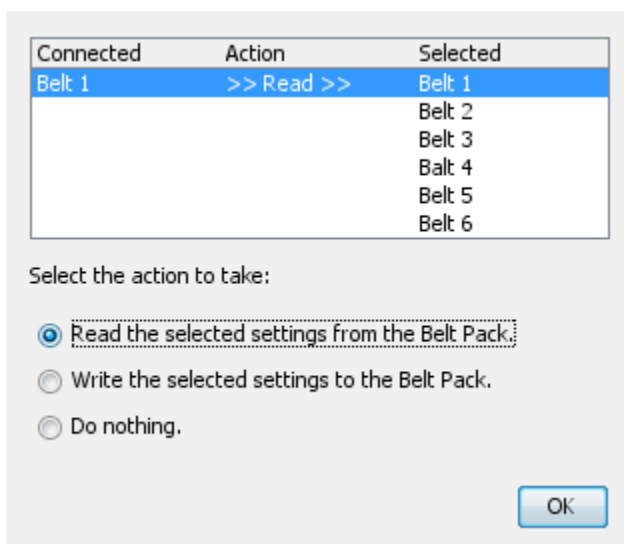

When a Belt Pack is connected via USB, select the Belt Pack Row to associate it with, and action to take:

Read from the Belt Pack.

All of the Belt Pack's current settings will be read into the Belt Pack Row.

Write to the Belt Pack.

All of the Belt Pack Row's current settings will be written (programmed) into the Belt Pack.

Do nothing.

No action will be taken, except that the Belt Pack will be associated with the selected Belt Pack Row.

ADD SCENE

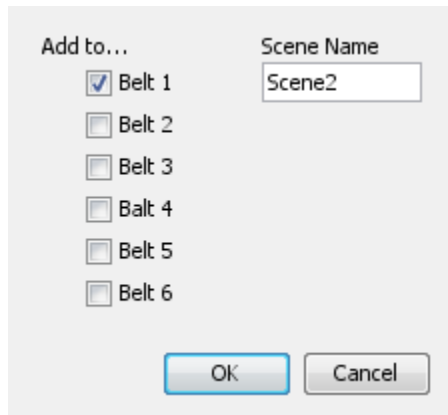

Specify a name and select the Belt Packs to add a Scene to.

Scene Name

Enter a name for the Scene. Scene names can be up to six characters in length.

Add to...

Select one or more Belt Packs to add a scene.

REMOVE SCENES

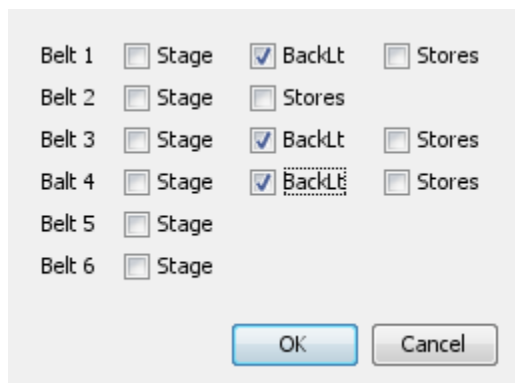

Select one or more Scenes to remove from one or more Belt Packs.

Select Scenes

If a user selects all of the Belt Pack's Scenes, they will all be removed, but because every Belt Pack must have at least one scene, a default Scene will be added back.

RENAME SCENES

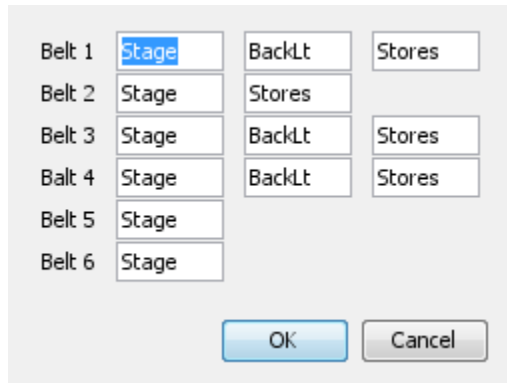

Scene Names

Rename any or all Scenes. Scene names can be up to six characters in length.

WRITE TO BELT PACKS

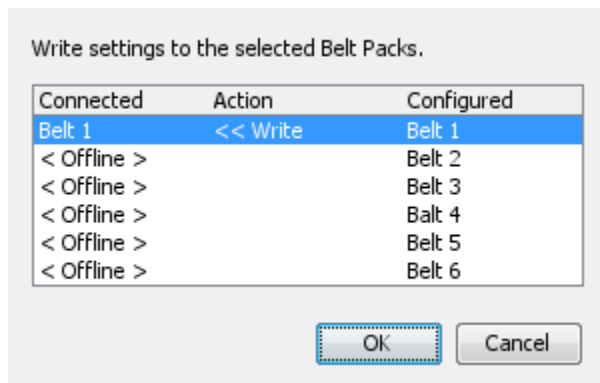

Write settings to one or more selected Belt Packs.

Connected ID

This is the ID of the connected Belt Pack, which may not match that of the Belt Pack Row with which it is associated.

Configured ID

This is the Belt Pack Row's ID which may not match that of the Belt Pack with which it is associated.

DIAGNOSTICS

This window displays in real time the logging output.

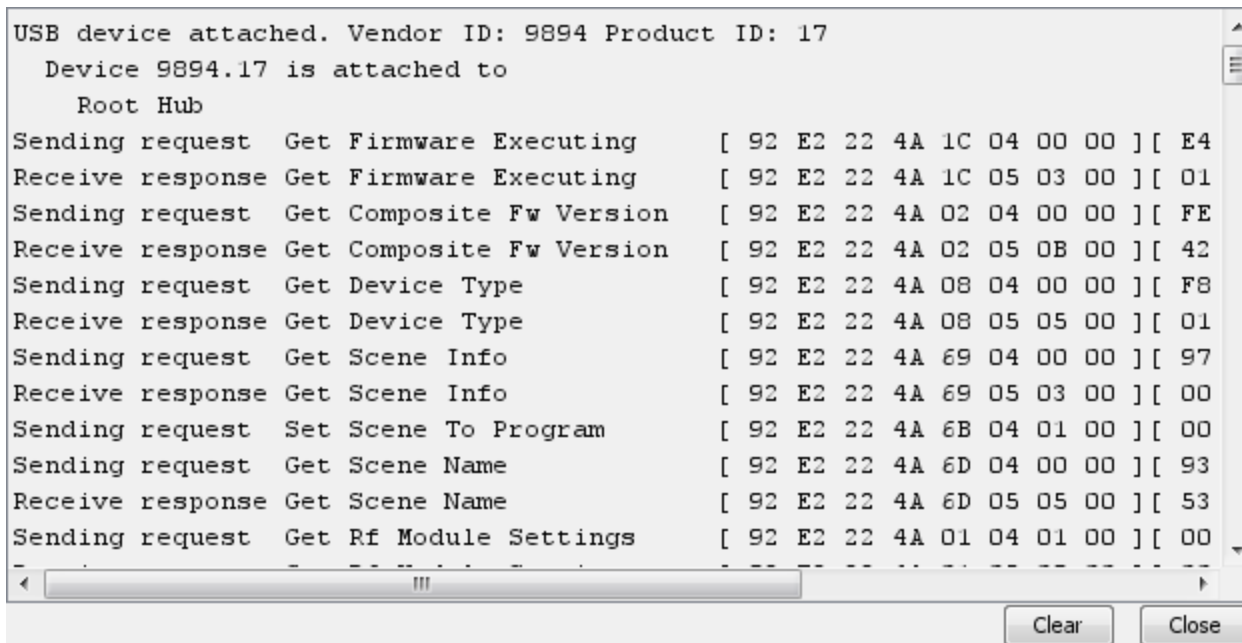

Clear

Clears the text from the window.

PASSCODES

Device	Digit 1	Digit 2	Digit 3	Digit 4	Enabled
Base Station	2	4	6	8	<input type="checkbox"/>
Belt Packs					
Belt 1	0	4	0	0	<input type="checkbox"/>
Belt 2	0	4	0	0	<input type="checkbox"/>
Belt 3	0	4	0	0	<input type="checkbox"/>
Belt 4	0	4	0	0	<input type="checkbox"/>
Belt 5	0	4	0	0	<input type="checkbox"/>
Belt 6	0	4	0	0	<input type="checkbox"/>

OK Cancel

Set and enable passcodes for the Base Station and Belt Packs.

Passcode Digits

A Base Station or Belt Pack can be passcode protected to prevent the user from making changes via the front panel UI. A passcode consists of four digits 0 through 9.

Enabling Passcodes

Passcode checking can be enabled or disabled.

Using Shortcut Keys

CTRL-D (COPY DOWN)

If the user sets one digit and then holds down the Ctrl key while pressing D (Ctrl-D), the passcode digit will be copied down to all fields below it. This makes it easy to set all devices to the same passcode.

BUTTON LABELS

In Common	Belt 1	Belt 2	Belt 3	Belt 4	Belt 5	Belt 6
PROD	PROD	PROD	PROD	PROD	PROD	PROD
SM	SM	SM	SM	SM	SM	SM
AUDIO	AUDIO	AUDIO	AUDIO	AUDIO	AUDIO	AUDIO
LIGHTS	LIGHTS	LIGHTS	LIGHTS	LIGHTS	LIGHTS	LIGHTS
VIDEO	VIDEO	VIDEO	VIDEO	VIDEO	VIDEO	VIDEO
MUSIC	MUSIC	MUSIC	MUSIC	MUSIC	MUSIC	MUSIC
CARPS	CARPS	CARPS	CARPS	CARPS	CARPS	CARPS
ELECT	ELECT	ELECT	ELECT	ELECT	ELECT	ELECT
RIGGERS	RIGGERS	RIGGERS	RIGGERS	RIGGERS	RIGGERS	RIGGERS

Labels for Each Belt Pack

The Belt Pack Tab allows the user to select button labels from a drop-down list of labels. Each Belt Pack has its own list of labels to select from. In addition to the standard labels, such as "CH 1", "CH 2", and "CH 1&2", the user can specify up to 34 custom labels to appear on those lists.

Labels can be up to eight characters in length.

Labels in Common

These are the most commonly used labels from all the lists. Use this list to help standardize other lists. Click the right arrows to copy to all columns. Click the top right arrow to copy all rows to all columns.

WRITE TO BELT PACKS

Allows the user to automatically write to (program) all Belt Packs one after another.

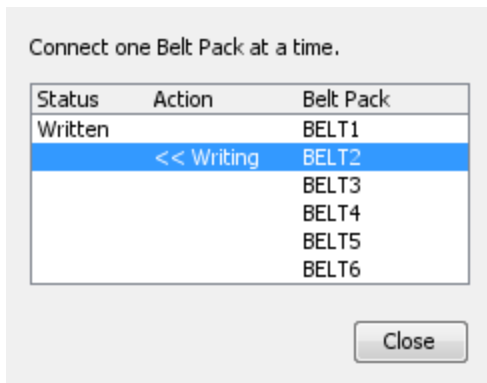

Auto Programming

Follow these steps to quickly write to (program) all six Belt Packs:

- 1) Disconnect all devices.
- 2) Open the Write to Belt Packs dialog.
- 3) Using a single USB cable, connect to one Belt Pack at a time.
- 4) As soon as that Belt Pack is written, disconnect it and connect to the next Belt Pack.
- 5) Continue until all Belt Packs have been written.

DEVICE FIRMWARE UPDATE

BASE STATION FIRMWARE

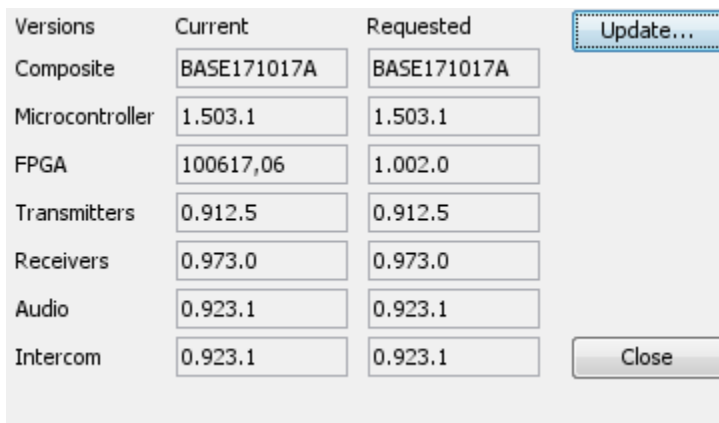

BELT PACK FIRMWARE

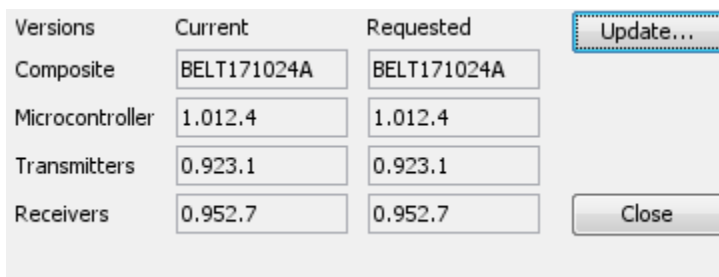

AUTOMATIC UPDATES

If a newly connected device **requires** a firmware update, a firmware dialog will automatically be presented.

CURRENT AND REQUESTED VERSIONS

The Current (old) and Requested (new) versions of the device's firmware are displayed.

The Composite version number refers to the entire firmware update, and the individual versions such as Microcontroller, Transmitter, and Receivers refer to the firmware of individual components.

UPDATE BUTTON

Click the Update button to proceed with the firmware update process.

Be patient — firmware updating may take as much as five minutes for a Belt Pack and fifteen minutes for a Base Station.

DO NOT UNPLUG THE USB CABLE OR POWER DOWN THE BASE STATION OR BELT PACK DURING THE UPDATE PROCESS!

CLOSE BUTTON

If the user clicks the Close button to continue without updating the device's firmware, the device may not connect to and work with the software.

SOFTWARE PREFERENCES

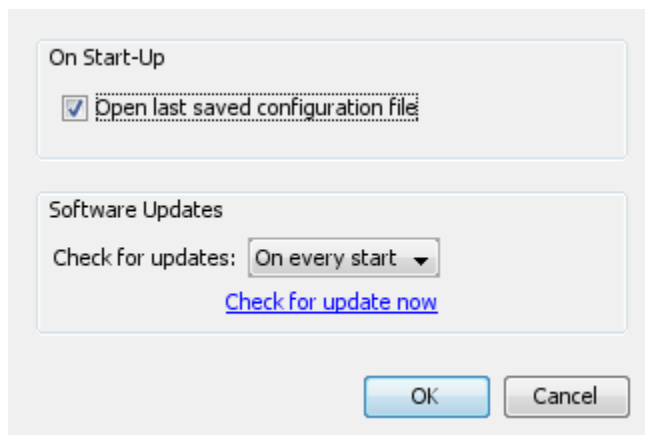

Customize how the software behaves on start-up, and how often to check for updates.

ON START-UP

Choose whether to automatically open the last saved configuration file on start-up.

SOFTWARE UPDATES

Choose whether to have the software automatically check for updates, and how often to do so.

Check for updates manually by clicking the "Check for update now" link.

PERMIT USE OF CHANNEL 37

Enable frequencies in channel 37.

Enter the passcode:

UHF channel 37, including the frequencies from 608 to 614 MHz, is reserved for radio astronomy. If the user and/or business has received permission from the FCC to use frequencies within that band, they may be enabled here.

Enable frequencies in channel 37.

Check the check box to enable, or un-check it to disable, frequencies in channel 37.

Enter the passcode:

To enable frequencies, the user will need to obtain a passcode from Radio Active Designs technical support.

DEVICE INFO

Information will be displayed for all connected devices, one device at a time.

The information displayed depends on whether the Device is a Base Station or a Belt Pack.

BASE STATION INFO

Serial Number	BS100442
Hardware Version	V2.0
Composite Firmware	BASE171010A
Microcontroller	1.503.0
FPGA	100617,06
Transmitters	0.912.5
Receivers	0.973.0
Audio	0.923.1
Intercom	0.923.1

BELT PACK INFO

Belt Pack Id	Belt 2
Serial Number	NO SERIAL#
Model Number	UV-1GBP1
Composite Firmware	BELT171010A
Microcontroller	1.012.2
Transmitter	0.923.1
Receivers	0.952.7

ABOUT RAD UV-1G



Software Version

Shows the current version number of the software.

Update Available

If a new version of the software is available, a link to download the update will appear.

USE OF OPEN SOURCE SOFTWARE

This software uses usb4java version 1.2.0, licensed under the GNU Lesser General Public License version 3 or later. Usb4java is an implementation of the javax.usb standard produced by (JSR 80). Usb4java depends upon commons-lang3 version 3.2.1, licensed under The Apache Software License, Version 2.0. This software also uses Gson version 2.3.1, licensed under the Apache 2.0 License.

2W PIN OUT

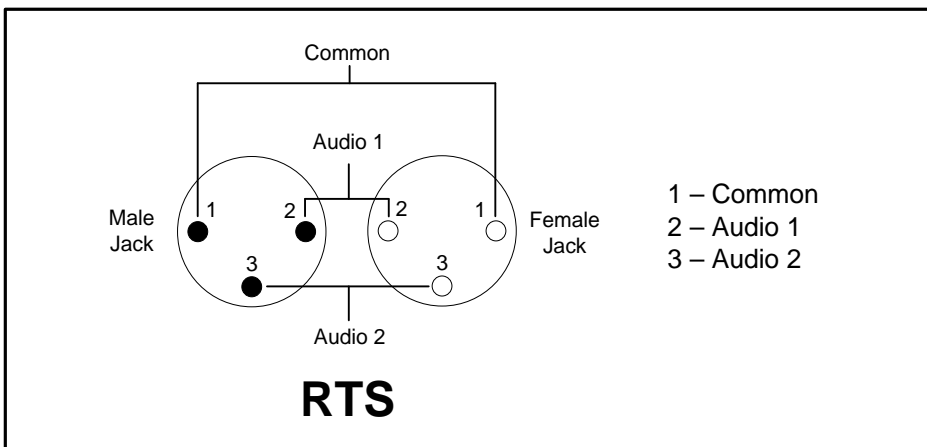
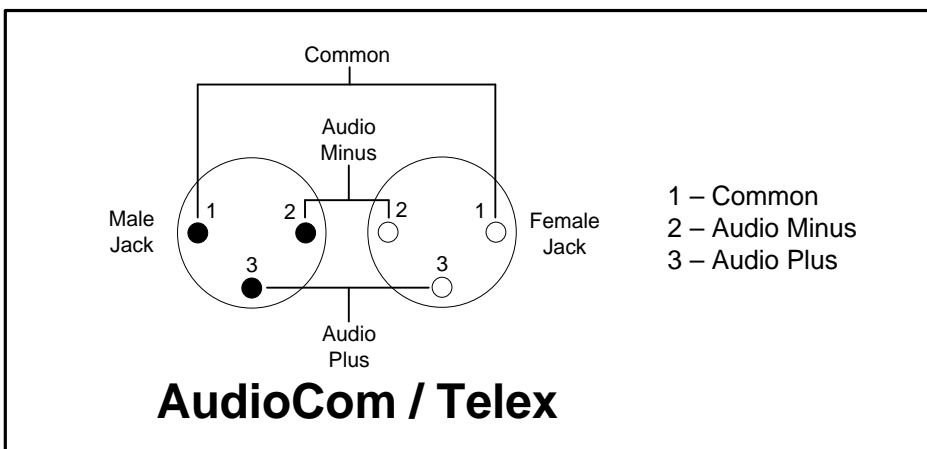
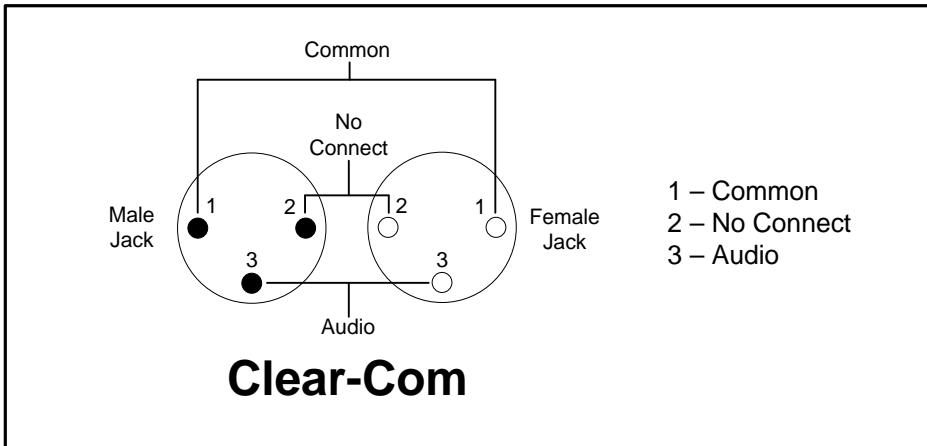

NOTE: DC power is not supplied – audio pins are AC coupled.

4W PIN OUT

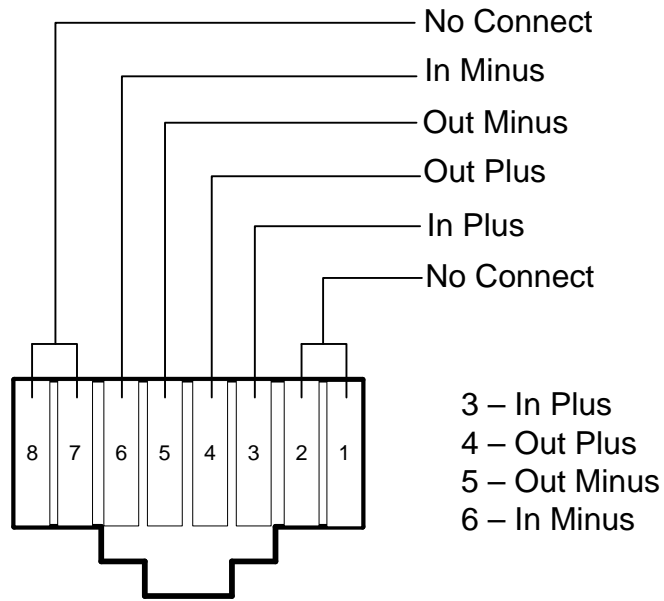

NOTE: Jack is RJ-11 and RJ-45 compatible.

TROUBLESHOOTING & FAQs

Wired intercom audio quality is poor.

The 2-wire intercom must be allowed to go through a brief automatic tuning process when everything is set up (cables are connected on both sides of wired intercom, units are powered on). To start this tuning process, press the given intercom enable button (#13 or #16 on Figure 1) until the associated 2W LED is illuminated green. This forces the system to start the tuning process. You may notice some low level white noise audio briefly on the intercom. This is used to tune the system. After a few seconds, the intercom will be tuned and ready to use.

Belt Pack audio levels are extremely low and sometimes momentarily spike loudly.

Ensure that two or more Belt Packs are not transmitting on the same frequency. This problem has been observed under these conditions.

Weak signal or poor reception on channel 2.

Check the base transmitter “separate” and “combine” switch to ensure that the two transmitters are feeding the ports that you intend to use. If you are going into a TX-8 combiner, then you must place the switch in “separate” and connect both transmitter antennas. If you are using one transmitter antenna, then you must place the switch in “combine.”

Details:

When using any transmitter combiner, it is necessary to limit the RF signals going in to each input to one frequency. This is because inserting more than one frequency into a single RF amplifier pallet will create RF intermodulation distortion. The Radio Active Designs UV-1G may be used stand alone or in a multiple system configuration with a transmitter combiner such as the TX-8.

In the stand-alone mode of operation, one may place a whip antenna directly on to the rear panel BNC of the unit. In this case, one would place the UV-1G in to “Combined” mode. If you are deploying any transmitter combiner you must place the switch in to the “Separate” mode. This will place the two internal transmitters on to both BNC RF output connections on the rear panel.

LEDs or LCD backlight on Base Station or Belt Pack will not turn on.

Blackout Mode may be enabled. Refer to the Display Settings section for more information on Blackout Mode.

Sweeping tone on belt pack.

One of the base station transmitters is disabled and the belt pack receiver is looking for a signal, or the belt pack receiver or base transmitter may be mistuned.

Details:

Radio Active Designs systems are deployed in a variety of Life Safety and Mission Critical applications. For this reason, we chose to implement a closed loop system from the belt pack out to the belt pack in.

In this manner, if you hear yourself in your own headset, then you can be assured that everyone else on the intercom system heard you as well. This is not the case with digital wireless intercom systems.

Due to the latency of these digital systems, a local side tone is used. This means that you will hear yourself perfectly in your own head set but there is no guarantee that anyone else on the comm system heard you at all. Radio Active Designs uses a “Costas Loop” to ensure that your side tone is a true representation of what everyone else is hearing. The sweeping tone in the belt pack is the receiver looking for the transmitter signal to lock to.

Issues connecting the link cable.

Make sure that all base stations are in “Master” mode and make all settings. Connect the cable and cycle power on the base stations. If using one to five “slave” base stations, make all setting in the “Master” Mode then change to “Slave”. Again, cycle power on all base stations with the link/sync cables connected.

Details:

Using the Sync cable on the rear panel of the Radio Active Designs UV-1G base station opens a world of possibilities. When all your base stations are synchronized with each other, any belt pack may be tuned across any two transmitter channels regardless of which set of base stations the transmitters are tuned to. In this manner, one may set multiple belt packs on to any set of two RF PL channels.

This is achieved by synchronizing the clock pulse of the Costas Loop mentioned above. When implementing Sync, the top unit in the rack provides the clock signal for all the base stations below it, or fed to it. This means that all the other base stations are seeking their internal clock sync from that first unit in the sync chain.

Once all the sync cables are connected, it is necessary to cycle power on all the base stations starting with the primary unit. This will establish the clock synchronizer pulse for the rest of the units. The units must be powered up in sequence from top to bottom so that each unit being powered up will sense the clock sync from the unit that is feeding it.

Hearing sounds of low level, distorted cross talk from the RAD on to my wired comm system.

You may be getting AM radiating RF on your wired comm through poorly shielded chassis or cable. Keep all systems powered up and disable the base transmitters. Get some distance between the base transmitter antenna and the wired comm cables and chassis. Also, use only the amount of RF power out of the base as is required for the task at hand. You rarely need to use 250 milliWatts.

Details:

Radio Active Designs implements Amplitude Modulation rather than traditional Frequency Modulation. This is because our goal from the start was Spectral Efficiency. Due to the fact that we are using AM, we can pack 200 belt packs and 30 base stations in the same UHF footprint as One 4 drop FM system. That makes us 30 times more spectrally efficient.

Amplitude Modulation can be demodulated inside of poorly shielded electronics equipment. In fact, all that is required to demodulate an AM signal is an active electronics circuit; even one that is not related to RF in the least. In addition, our RAD UV-1G uses direct conversion meaning that there is no Intermediate Frequency. The RF signal IS the audio signal. This is why you hear some form of the audio being transmitted on the base station.

Hearing RF fade noise when keying up a belt pack with no head set connected.

The headset cable is the counterpoise for the VHF transmitter antenna. It must be connected for proper transmission from the belt pack.

Details:

Radio Active Designs belt packs transmit in the VHF band from 174-216 MHz which is TV channel 7 through 13. If we used an external antenna for the belt pack, it would be 16 inches long! Probably wouldn't go over too well nowadays.

That is why we designed an internal meander antenna for transmission from the belt pack. We use the head set cable as the counterpoise for the transmit antenna thus the head set must be connected for maximum transmission.

Belt pack does not transmit when Channel 1 is not tuned.

The belt pack locks to Channel 1 to ensure a closed loop system. Channel 1 must be turned on in the belt pack receiver. If you do not want to hear it, turn the volume control down.

Details:

Radio Active Designs wireless intercom systems are used in mission critical operations from Nuclear power plants to Space vehicle launch communications. We deploy a Costas Loop closed locked loop system for the side tone. The Costas Loop signal is transmitted on channel 1 of the base station. It is necessary to tune your belt pack to channel 1 to assure proper lock.

Receiving short range when transmitting from the pack while a short distance away from the base station.

Check for proper placement of RX antenna in comparison to TX antenna.

Check your operating frequencies.

Check your RF 50ohm Low Loss cables.

Details:

- Check your placement of your base station RX antenna and make sure it is not in front of a TX antenna or pointed directly and positioned too close to a video wall or another piece of equipment that puts out high RF noise. RX antennas should be placed high, behind and to the side of a TX antenna and away from items such as Power Distribution, lighting dimmers and video walls. TX antennas should be placed high as well.

- Check your TX and RX frequencies of your base station to make sure they are not being stepped on by other frequencies or tuned in a high noise floor environment. If the frequency is clean, but there is a higher than normal noise floor, you can attenuate the RX sensitivity at the base station to help lower the noise floor. The pack will TX out more effectively to the base station. You can do this individually or globally.
- Check your 50ohm Low Loss RF cables for a short in the connector (shield touching the core) or possibly a broken pin in the connector. Cables get damaged if not taken care of.

Can I power up a base station without hooking up the antennas?

It is not recommended unless you power up in TX Off mode.

Details:

It is not a good idea to power up the base station without antennas connected because the TX amplifier is looking for a load when it is powered up. An amplifier with no load will cause strain on the amp and shorten its life or cause it to fail.

An alternative is to power up the Base Station in TX off mode. Hold the TALK button on the right while turning on the Base Station. Let go of the TALK button until you see "TX OFF" in the LCD screen. Another benefit of doing this is that your base station won't interfere with any other frequencies at your location if your base station is not already programmed. You can turn the TX in the base station back on manually or by using the software to program it.

Will my batteries drain if I leave them in the battery charger turned off over night?

No, your batteries will not drain if left in an unpowered battery charger. Always top off a battery before an event if left unused in or out of the battery charger for longer than a day.

Why don't I hear the side tone in my packs from my Slave Linked base stations when I key up?

Make sure all your base station RX inputs are connected to an antenna via a VF-8 or DB-VIC RX multi-coupler.

Can I wear a 2-way radio right next to my RAD Pack?

RAD recommends the user to wear a two-way radio on the OPPOSITE side of the RAD pack to avoid interference between each other. The 2-way Radio transmission can potentially damage the receiver board in the RAD pack if it is a few inches in proximity.

This page intentionally left blank.