

E

E8
Manual 2.1 en

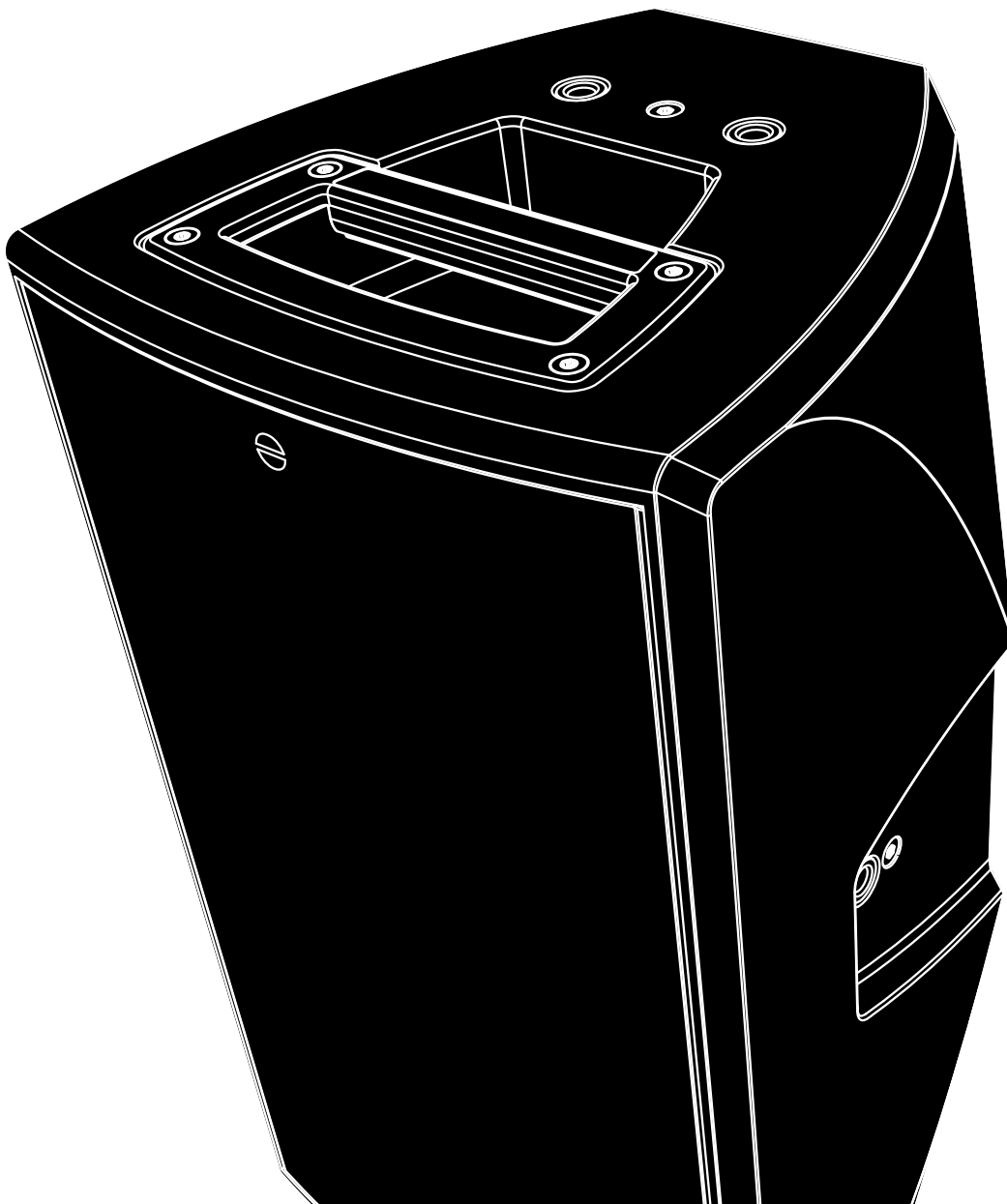

General information

E8 Manual

Version: 2.1 en, 09/2017, D2030.EN .02

Copyright © 2017 by d&b audiotechnik GmbH; all rights reserved.

Keep this manual with the product or in a safe place so that it is available for future reference.

When reselling this product, hand over this manual to the new owner.

If you supply d&b products, please draw the attention of your customers to this manual. Enclose the relevant manuals with the systems. If you require additional manuals for this purpose, you can order them from d&b.

d&b audiotechnik GmbH
Eugen-Adolff-Strasse 134, D-71522 Backnang, Germany
T +49-7191-9669-0, F +49-7191-95 00 00
docadmin@dbaudio.com, www.dbaudio.com

1. Safety precautions	4
1.1. Information regarding the use of loudspeakers.....	4
2. E8 loudspeaker	5
2.1. E8 Product description.....	5
2.2. Connections.....	5
2.3. Operation.....	6
2.3.1. Controller settings.....	7
2.3.2. Operation with E-PAC.....	7
2.4. Dispersion characteristics.....	8
2.5. Technical specifications.....	10
3. Manufacturer's Declarations	11
3.1. EU conformity of loudspeakers (CE symbol).....	11
3.2. WEEE Declaration (Disposal).....	11

1.1. Information regarding the use of loudspeakers

Potential risk of personal injury

Never stand in the immediate vicinity of loudspeakers driven at a high level. Professional loudspeaker systems are capable of causing a sound pressure level detrimental to human health. Seemingly non-critical sound levels (from approx. 95 dB SPL) can cause hearing damage if people are exposed to it over a long period.

In order to prevent accidents when deploying loudspeakers on the ground or when flown, please take note of the following:

- When setting up the loudspeakers or loudspeaker stands, make sure they are standing on a firm surface. If you place several systems on top of one another, use straps to secure them against movement.
- Only use accessories which have been tested and approved by d&b for assembly and mobile deployment. Pay attention to the correct application and maximum load capacity of the accessories as detailed in our specific "Mounting instructions" or in our "Flying system and Rigging manuals".
- Ensure that all additional hardware, fixings and fasteners used for installation or mobile deployment are of an appropriate size and load safety factor. Pay attention to the manufacturers' instructions and to the relevant safety guidelines.
- Regularly check the loudspeaker housings and accessories for visible signs of wear and tear, and replace them when necessary.
- Regularly check all load bearing bolts in the mounting devices.

Potential risk of material damage

Loudspeakers produce a static magnetic field even if they are not connected or are not in use. Therefore make sure when erecting and transporting loudspeakers that they are nowhere near equipment and objects which may be impaired or damaged by an external magnetic field. Generally speaking, a distance of 0.5 m (1.5 ft) from magnetic data carriers (floppy disks, audio and video tapes, bank cards, etc.) is sufficient; a distance of more than 1 m (3 ft) may be necessary with computer and video monitors.

2. E8 loudspeaker

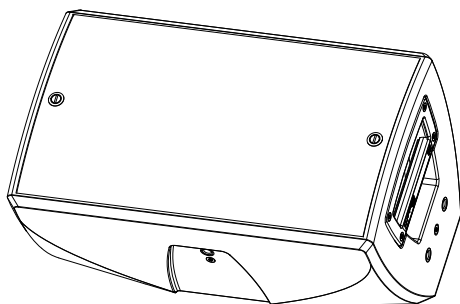
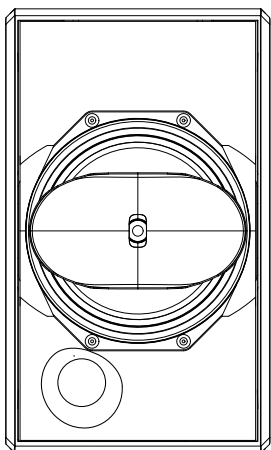

E8 loudspeaker and monitor position

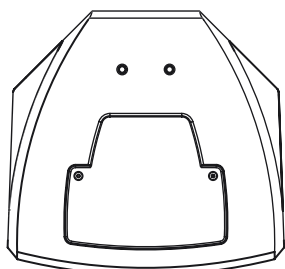

SC/WR variants, top and bottom view

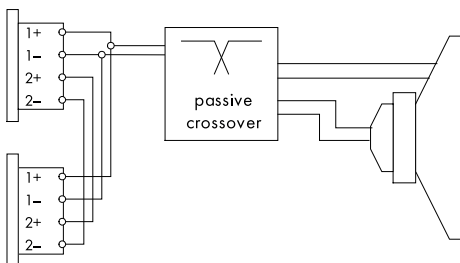

Connector wiring

2.1. E8 Product description

The E8 is a high performance multipurpose loudspeaker employing an integrated 8"/1" exit coaxial driver design with neodymium magnet and constant directivity horn loading. The horn with its 90° x 50° (hor. x vert.) dispersion pattern can easily be rotated through 90° providing a 50° x 90° pattern without the use of tools.

The E8 is a two-way design with a built-in passive crossover network. Its frequency response extends from 62 Hz to 18 kHz.

The enclosure is constructed from polyurethane integral hard foam with an impact resistant paint finish. The cabinet shape allows use either in a vertical or horizontal orientation as well as deployment as a stage monitor. The front of the loudspeaker cabinet is protected by a rigid metal grill backed by an acoustically transparent foam.

The loudspeaker cabinet incorporates a handle, a pole mount socket and six M10 threaded inserts to connect to different rigging accessories like Z5350 Flying bracket E8, Z5020 Flying adapter 02, Z5025 Flying adapter 03 or a Z5351 Horizontal bracket E8. An additional M10 thread in the rear panel can be used to connect a safety wire.

The connector panel of the E8 cabinet is recessed and tilted to allow deployment as a stage monitor. With the panel on the right hand side, the cabinet is oriented correctly.

Cabinet options

The special color (SC) version of the cabinet is available in all colors of the RAL color table. It comes without high stand flange and handles. The respective openings of the cabinet are covered by plates in cabinet color. The connector type is NLT4.

The weather resistant (WR) version is available in black only. It also comes without high stand flange and handles. It is equipped with a fixed input cable (PG: 5.5 m / 18 ft, type H07-RN-F 2 x 2.5 mm² / AWG 13).

2.2. Connections

The cabinet is fitted with NLT4 F/M connectors. All four pins of both connectors are wired in parallel. The cabinet uses the pin assignments 1+/1-. Pins 2+/2- are designated to actively driven subwoofers. Using one connector as the input, the second connector allows for direct connection to a second cabinet.

NLT4 F/M	1+	1-	2+	2-	-
EP5	1	2	3	4	5
PG	Brown (+)	Blue (-)	-	-	-

2.3. Operation

NOTICE!

Only operate d&b loudspeakers with a correctly configured d&b amplifier, otherwise there is a risk of damaging the loudspeaker components.

Applicable d&b amplifiers:

D80/D20/D12/D6/10D/30D.

Standard operation

Application	Setup	Cabinets per channel
E8	E8	4

For applicable d&b amplifiers, the controller setup is available in Dual Channel and/or Mix TOP/SUB mode. For combinations with active subwoofers fed by a single 4-wire cable Mix TOP/SUB mode must be selected.

Passive operation

Application	Setup	Combination per channel
E8 with E12X-SUB	E8-X	3

In Dual Channel mode, the "X" setup can be selected to drive the cabinet in combination with the E12X subwoofer on the same channel.

The setup provides a dedicated correction for the combined frequency response of the system.

2.3.1. Controller settings

For acoustic adjustment the functions CUT, HFA and CPL can be selected.

CUT mode

Set to CUT, the low frequency level is reduced. The cabinet is now configured for use with actively driven d&b subwoofers.

HFA mode

In HFA mode (High Frequency Attenuation), the HF response of the system is rolled off. HFA provides a natural, balanced frequency response when a cabinet is placed close to listeners in near field or delay use.

High Frequency Attenuation begins gradually at 1 kHz, dropping by approximately 3 dB at 10 kHz. This roll off mimics the decline in frequency response experienced when listening to a system from a distance in a typically reverberant room or auditorium.

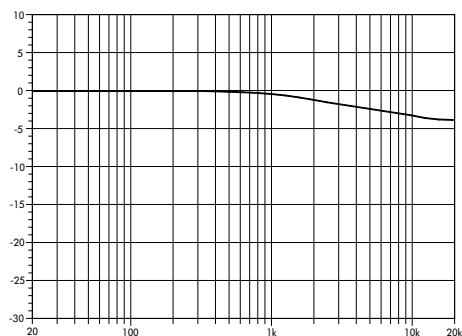

Frequency response correction in HFA mode

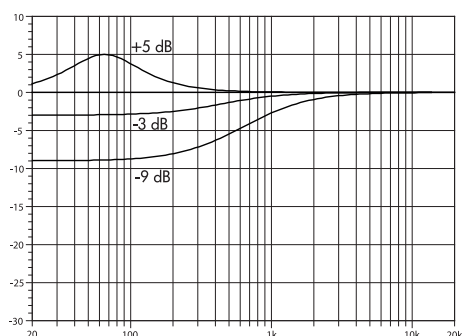

Frequency response correction of the CPL function

CPL function

The CPL (Coupling) function compensates for coupling effects between the cabinet and close boundary surfaces or when the cabinet is used as a stage monitor. CPL begins gradually around 1 kHz, with the maximum attenuation below 250 Hz. To achieve a balanced frequency response, the CPL function can be set to dB attenuation values between 0 and -9.

Positive CPL values create an adjustable low frequency boost (0 to +5 dB) and can be set when the system is used in full range mode without subwoofers.

2.3.2. Operation with E-PAC

Selecting E8 mode enables the E-PAC to drive up to two E8 loudspeakers. LO IMP mode configures the E-PAC to drive a maximum of four E8 loudspeakers with a 6 dB reduction in input level to the loudspeakers.

For acoustic adjustment the CUT and HFA modes are available. The characteristics are described in the previous section.

2.4. Dispersion characteristics

The following graphs show dispersion angle over frequency of a single cabinet plotted using lines of equal sound pressure (isobars) at -6 dB and -12 dB.

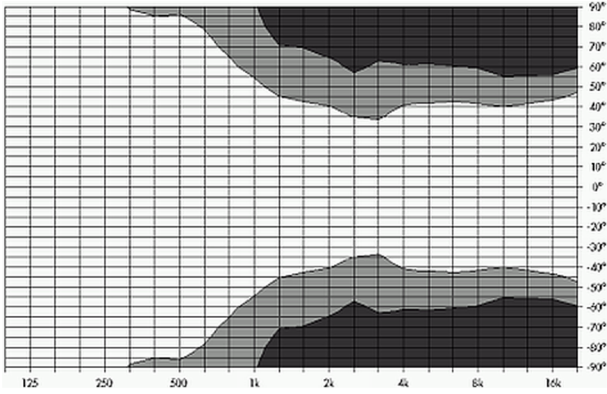

Isobar diagram horizontal

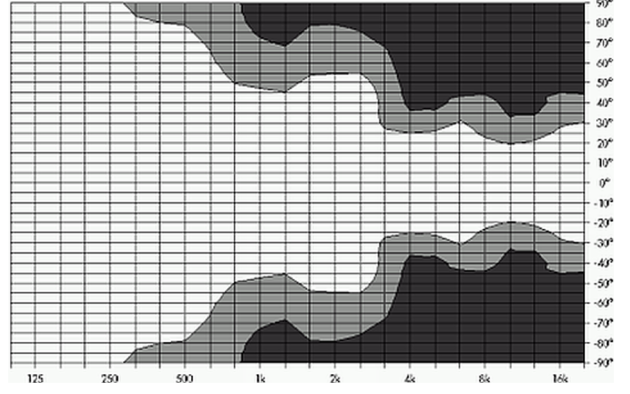
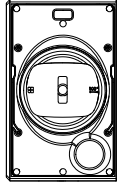

Isobar diagram vertical

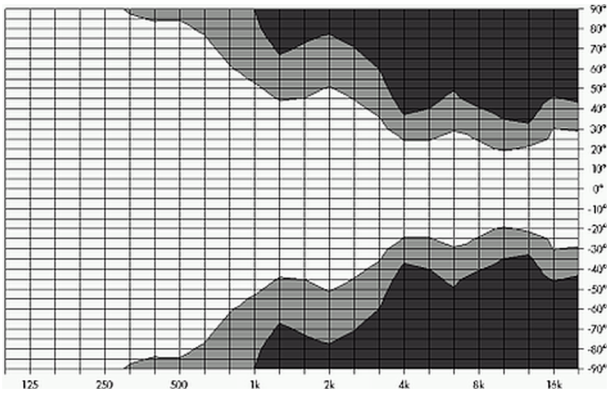

Isobar diagram horizontal

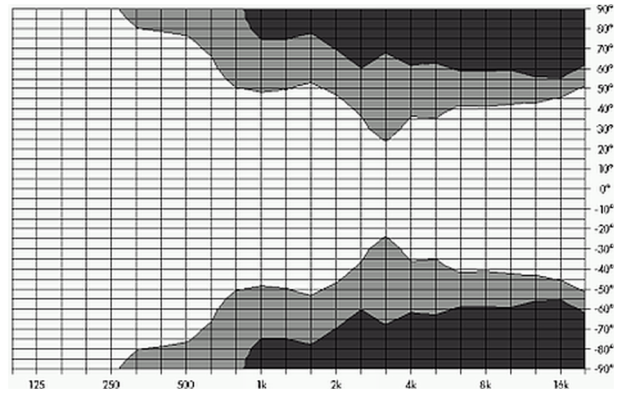
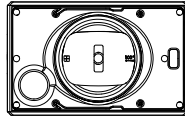

Isobar diagram vertical

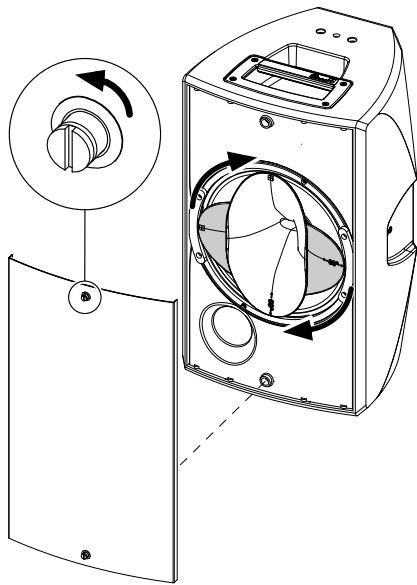

Rotating the horn

Altering the HF horn dispersion

The HF horn can be rotated through 90° within the coaxial driver assembly.



CAUTION!

Potential risk of personal injury due to falling objects.

- Set the correct horn orientation before suspending the cabinet.
- Do not remove the front grill while the cabinet is mounted or flown above the ground.

Tools required: screw driver or an appropriate coin.

1. Disconnect the loudspeaker.
2. Undo the quick locks at the top and bottom of the front grill and remove the grill.
3. Pick the horn at its outer edges and turn it until it snaps into the desired orientation.
4. Relocate and fix the front grill.
 - ⇒ Make sure both quick locks of the front grill are locked correctly before using the loudspeaker.

2.5. Technical specifications

E8 system data

Frequency response (-5 dB standard mode)	62 Hz - 18 kHz
Frequency response (-5 dB CUT mode)	120 Hz - 18 kHz
Max. sound pressure (1 m, free field)	
with D6/10D/E-PAC	126 dB
with D12/D20/30D	129 dB
with D80	129 dB
	(SPLmax peak, pink noise test signal with crest factor 4)

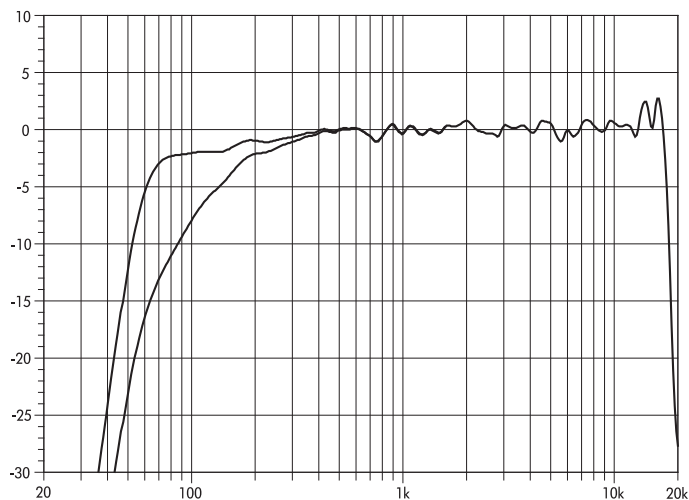

E8 frequency response, standard and CUT modes.

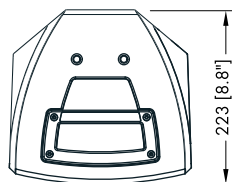
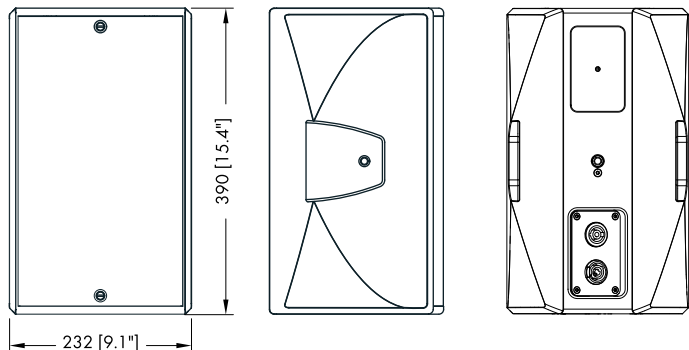
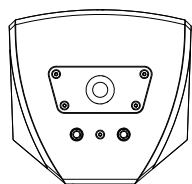

E8 cabinet dimensions in mm [inch]

E8 loudspeaker

Nominal impedance	16 ohms
Power handling capacity (RMS/peak 10 ms)	150/800 W
Nominal dispersion angle (hor. x vert.)	90° x 50°
Components	8" driver with neodymium magnetcoaxial 1" exit compression driver with 1.75" coil and rotatable CD horn Passive crossover network
Connections	2 x NLT4 F/M Optional: 2 x EP5 SC option: 2 x NL4 M ... WR option: Fixed cable 5.5 m (18 ft) HO7-RN-F 2 x 2.5 mm ² /AWG 13
Pin assignments	NLT4 F/M: 1+/1- EP5: 1+/2- Fixed cable: Brown + / Blue -
Weight	7.3 kg (16.1 lb)



3.1. EU conformity of loudspeakers (CE symbol)

This declaration applies to:

d&b E8 loudspeaker, Z0620

manufactured by d&b audiotechnik GmbH.

All production versions of these types are included, provided they correspond to the original technical version and have not been subject to any later design or electromechanical modifications.

We herewith declare that said products are in conformity with the provisions of the respective EC directives including all applicable amendments.

A detailed declaration is available on request and can be ordered from d&b or downloaded from the d&b website at www.dbaudio.com.

3.2. WEEE Declaration (Disposal)

Electrical and electronic equipment must be disposed of separately from normal waste at the end of its operational lifetime.

Please dispose of this product according to the respective national regulations or contractual agreements. If there are any further questions concerning the disposal of this product, please contact d&b audiotechnik.



